

STRATA PLAN OF PART OF LOT 36, AND AN UNDIVIDED 944/10000 INTEREST IN LOT 11, PLAN 19070, BLOCK F, DISTRICT LOT 4749, PLAN 22122, GROUP 1, N.W.D. "FORM E GC 34811"

FIRST SHEET SHEET 1 OF 30 SHEETS  
 STRATA PLAN VR 2381  
 DEPOSITED AND REGISTERED IN THE LAND TITLE OFFICE AT VANCOUVER, B.C., THIS 20<sup>th</sup> DAY OF MARCH, 1989.

SCALE 1 : 1250

THIS PLAN LIES WITHIN THE SQUAMISH-LILLOOET REGIONAL DISTRICT RESORT MUNICIPALITY OF WHISTLER

THE ADDRESS FOR SERVICE OF DOCUMENTS ON THE STRATA CORPORATION IS: - THE OWNERS STRATA PLAN VR 2381

CHRIST - WILLIAMS  
 880-1090 W. GEORGIA STREET  
 VANCOUVER, B.C.

CIVIC ADDRESS :  
 2240 GONDOLA WAY

ASSISTANT DEPUTY REGISTRAR

*[Signature]*

GC 34812  
 BLK. A

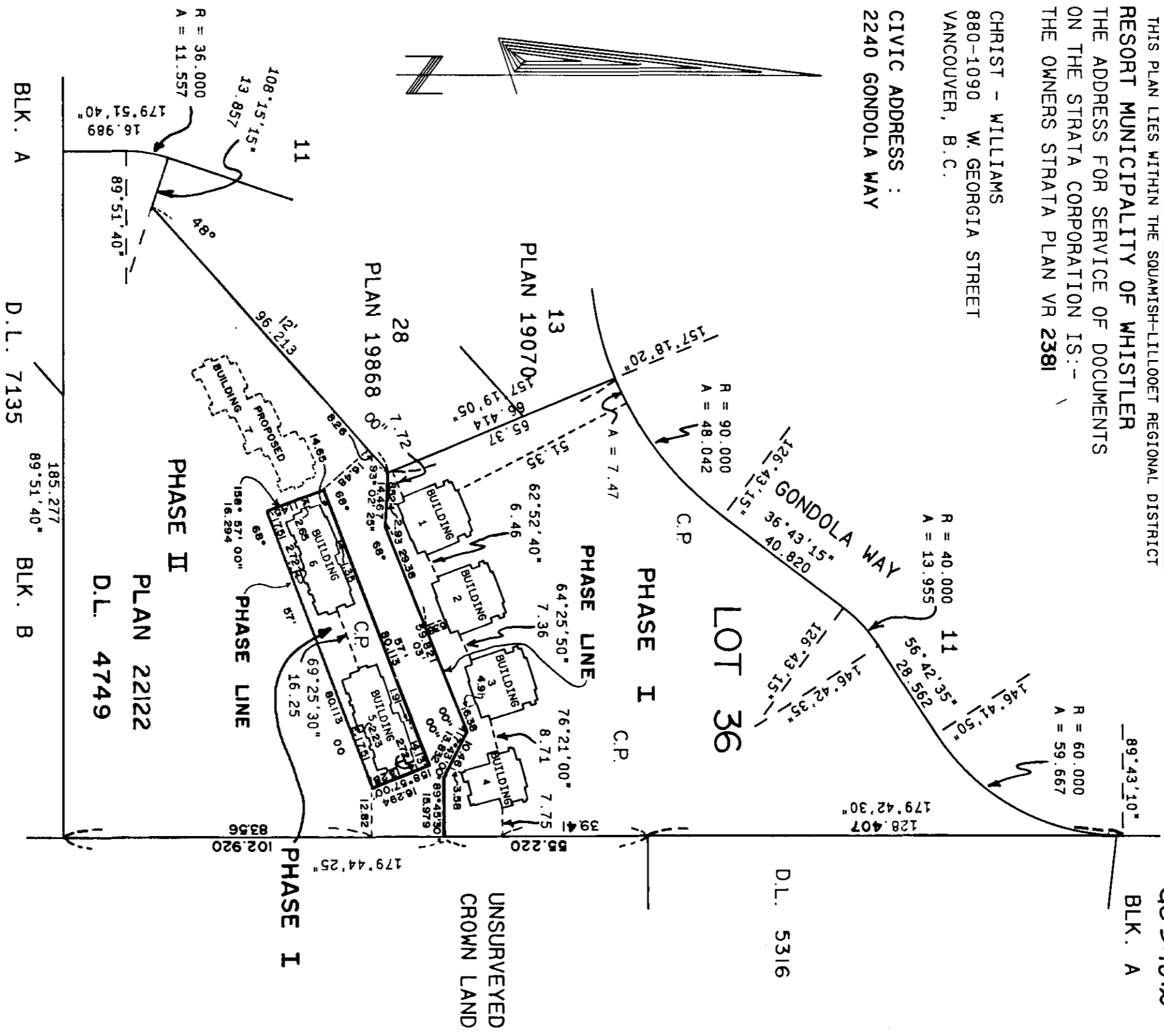

NOTE :  
 C.P. denotes COMMON PROPERTY  
 L.C.P. denotes LIMITED COMMON PROPERTY  
 ALL DISTANCES ARE IN METRES

I, BRIAN O. BROWN, OF WHISTLER, B.C., A BRITISH COLUMBIA LAND SURVEYOR, HEREBY CERTIFY THAT THE BUILDINGS ERECTED ON THE PARCEL DESCRIBED ABOVE ARE WHOLLY WITHIN THE EXTERNAL BOUNDARIES OF THAT PARCEL. DATED AT WHISTLER, B.C. THIS 16th DAY OF JANUARY, 1989.

*[Signature: Brian O. Brown]*

Robert B. Brown & Associates  
 Professional Land Surveyors  
 P.O. Box 13, Whistler, B.C.  
 VON 1B0 932 - 5426

B.C.L.S.

J88038

SP883588

CONDOMINIUM ACT  
PHASE I

STRATA PLAN VR 2381

SECOND SHEET SHEET 2 OF 30 SHEETS

LOT NO.	SHEET NO.	FORM 1 SECTION 3(1)(f)		FORM 2 SECTION 3(1)(g)		FORM 3 SECTION 3(1)(h)	
		SCHEDULE OF UNIT ENTITLEMENT	UNIT ENTITLEMENT	SCHEDULE OF INTEREST UPON DESTRUCTION	INTEREST UPON DESTRUCTION	SCHEDULE OF VOTING RIGHTS	NUMBER OF VOTES
1	5		5154		92		
2	5		5154		92		
3	6		4805		92		
4	6		4801		92		
5	7		4854		95		
6	7		4854		95		
7	8		5196		92		
8	8		5160		92		
9	9&10		12050		183		
10	9&10		12040		183		
11	11		5111		92		
12	11		5111		92		
13	12&13		12040		183		
14	12&13		12010		183		
15	14		4780		92		
16	14		4780		92		
17	15		4812		95		
18	15		4812		95		
19	16,17,18		11950		180		
20	16,17,18		11580		175		
21	16,17,18		11590		175		
22	16,17,18		11940		180		
23	19,20,21		12050		180		
24	19,20,21		11660		175		
25	19,20,21		11660		175		
26	19,20,21		12050		180		
AGGREGATE			212004		3452		

ACCEPTED AS TO FORMS 1, 2 & 3  
This 15 Day of March, 1989.

*[Signature]*  
SUPERINTENDENT OF REAL ESTATE

Robert B. Brown & Associates  
Professional Land Surveyors  
P.O. Box 13, Whistler, B.C.  
VON 1B0 932 - 5426

*[Signature]*  
B.C.L.S.  
January 16, 1989

J88038

SP88358B

CONDOMINIUM ACT  
PHASE I

STRATA PLAN VR 2381

STATUTORY DECLARATION

I, THE UNDERSIGNED, DO SOLEMNLY DECLARE THAT:-  
(1) I, THE UNDERSIGNED, AM THE DULY AUTHORIZED AGENT OF THE OWNER DEVELOPER  
(2) THE STRATA PLAN IS ENTIRELY FOR RESIDENTIAL USE  
I MAKE THIS SOLEMN DECLARATION CONSCIENTIOUSLY BELIEVING IT TO BE TRUE, AND  
KNOWING THAT IT IS OF THE SAME FORCE AND EFFECT AS IF MADE UNDER OATH.

DECLARED BEFORE ME AT - Vancouver  
IN THE PROVINCE OF BRITISH COLUMBIA  
THIS 13th DAY OF February, 1989.

William Alan Janyk  
William Alan Janyk

COMMISSIONER FOR TAKING AFFIDAVITS WITHIN THE  
PROVINCE OF BRITISH COLUMBIA  
M. A. Christ

SIGNATURES  
OWNERS

MORTGAGEES

~~MONTREAL TRUST COMPANY~~

William Alan Janyk  
WILLIAM ALAN JANYK

AUTHORIZED SIGNATORY

WITNESS M. A. Christ

AUTHORIZED SIGNATORY  
AETNA TRUST COMPANY

ADDRESS 880-1090 W. Georgia St. Van.

AUTHORIZED SIGNATORY

OCCUPATION Solicitor

Ronald George Albertin  
RONALD GEORGE ALBERTIN

AUTHORIZED SIGNATORY  
RICHMOND SAVINGS CREDIT UNION

WITNESS M. A. Christ

AUTHORIZED SIGNATORY

ADDRESS 880-1090 W. Georgia St. Van.

OCCUPATION Solicitor

C.H.N. INVESTMENTS LTD.

[Signature]  
AUTHORIZED SIGNATORY

I, BRIAN O. BROWN OF THE MUNICIPALITY  
OF WHISTLER, BRITISH COLUMBIA LAND  
SURVEYOR, HEREBY CERTIFY THAT THE  
BUILDING SHOWN IN THIS STRATA PLAN  
HAS NOT, AS OF THE 16th DAY OF JANUARY,  
1989 BEEN PREVIOUSLY OCCUPIED DATED  
AT WHISTLER, BRITISH COLUMBIA  
THIS 16th DAY OF JANUARY, 1989.

AUTHORIZED SIGNATORY

Brian O. Brown  
B.C.L.S.

APPROVED AS PHASE 1 OF A 2 PHASE  
STRATA PLAN UNDER THE "CONDOMINIUM ACT"  
THIS 7 DAY OF FEBRUARY 1989

[Signature]  
APPROVING OFFICER - RESORT MUNICIPALITY OF WHISTLER

Robert B. Brown & Associates  
Professional Land Surveyors  
P.O. Box 13, Whistler, B.C.  
V0N 1B0 932 - 5426

[Signature] B.C.L.S.  
January 16, 1989

J88038

SP883588

STRATA PLAN VR 2381

PHASE I

SHARES OF UNDIVIDED 944/10000  
INTEREST IN LOT 11

S.L. NO.	AREA	SHARE OF UNDIVIDED 944/10000 INTEREST IN LOT 11
1	51.54 m <sup>2</sup>	18/10000
2	51.54 m <sup>2</sup>	18/10000
3	48.05 m <sup>2</sup>	16/10000
4	48.01 m <sup>2</sup>	16/10000
5	48.54 m <sup>2</sup>	17/10000
6	48.54 m <sup>2</sup>	17/10000
7	51.96 m <sup>2</sup>	18/10000
8	51.60 m <sup>2</sup>	18/10000
9	120.5 m <sup>2</sup>	41/10000
10	120.4 m <sup>2</sup>	41/10000
11	51.11 m <sup>2</sup>	17/10000
12	51.11 m <sup>2</sup>	17/10000
13	120.4 m <sup>2</sup>	41/10000
14	120.1 m <sup>2</sup>	41/10000
15	47.80 m <sup>2</sup>	16/10000
16	47.80 m <sup>2</sup>	16/10000
17	48.12 m <sup>2</sup>	16/10000
18	48.12 m <sup>2</sup>	16/10000
19	119.5 m <sup>2</sup>	40/10000
20	115.8 m <sup>2</sup>	39/10000
21	115.9 m <sup>2</sup>	39/10000
22	119.4 m <sup>2</sup>	40/10000
23	120.5 m <sup>2</sup>	41/10000
24	116.6 m <sup>2</sup>	40/10000
25	116.6 m <sup>2</sup>	40/10000
26	120.5 m <sup>2</sup>	41/10000
TOTALS	2120.04 m <sup>2</sup>	720/10000

PHASE II ----- 224/10000

 B.C.L.S.

January 16, 1989

J88038

SP88358B

PLAN OF STRATA LOTS 1 & 2  
PHASE I STRATA PLAN VR 2381

SHEET 5 OF 30 SHEETS

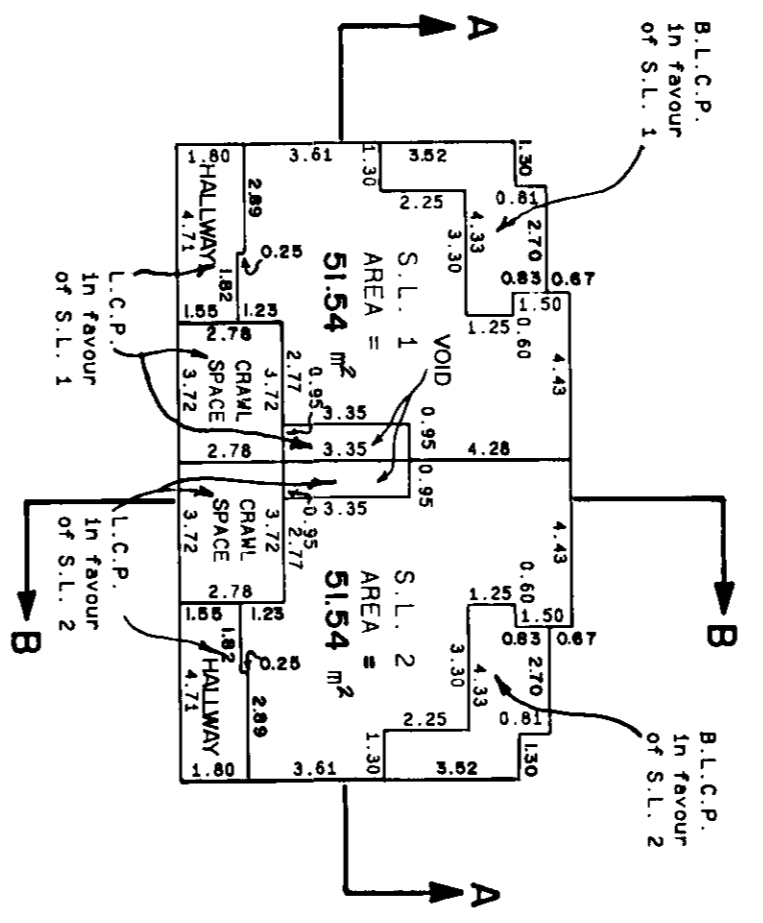
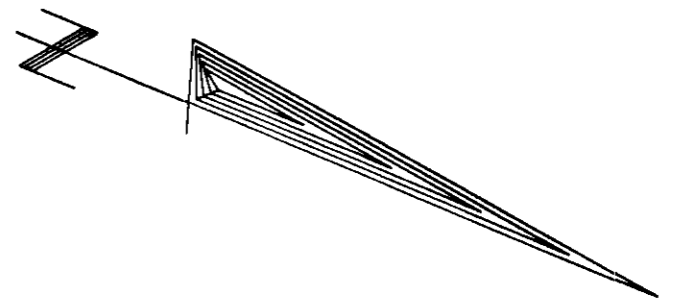
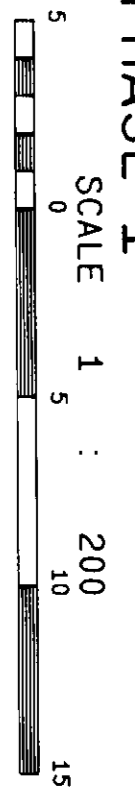

PLAN OF GROUND FLOOR  
BUILDING 1

- NOTE:
- S.L. DENOTES STRATA LOT
  - C.P. DENOTES COMMON PROPERTY
  - L.C.P. DENOTES LIMITED COMMON PROPERTY
  - C.F. DENOTES COMMON FACILITY
  - PT. DENOTES PART
  - B. DENOTES BALCONY
- BALCONIES ARE COMMON PROPERTY AND ARE NOT INCLUDED IN SQUARE METRE (M²) AREAS  
ALL DISTANCES ARE IN METRES.

B.C.L.S.

January 16, 1989

J98038

SP88358B

# PLAN OF STRATA LOTS 384 PHASE I

# STRATA PLAN VR 2381

SHEET 6 OF 30 SHEETS

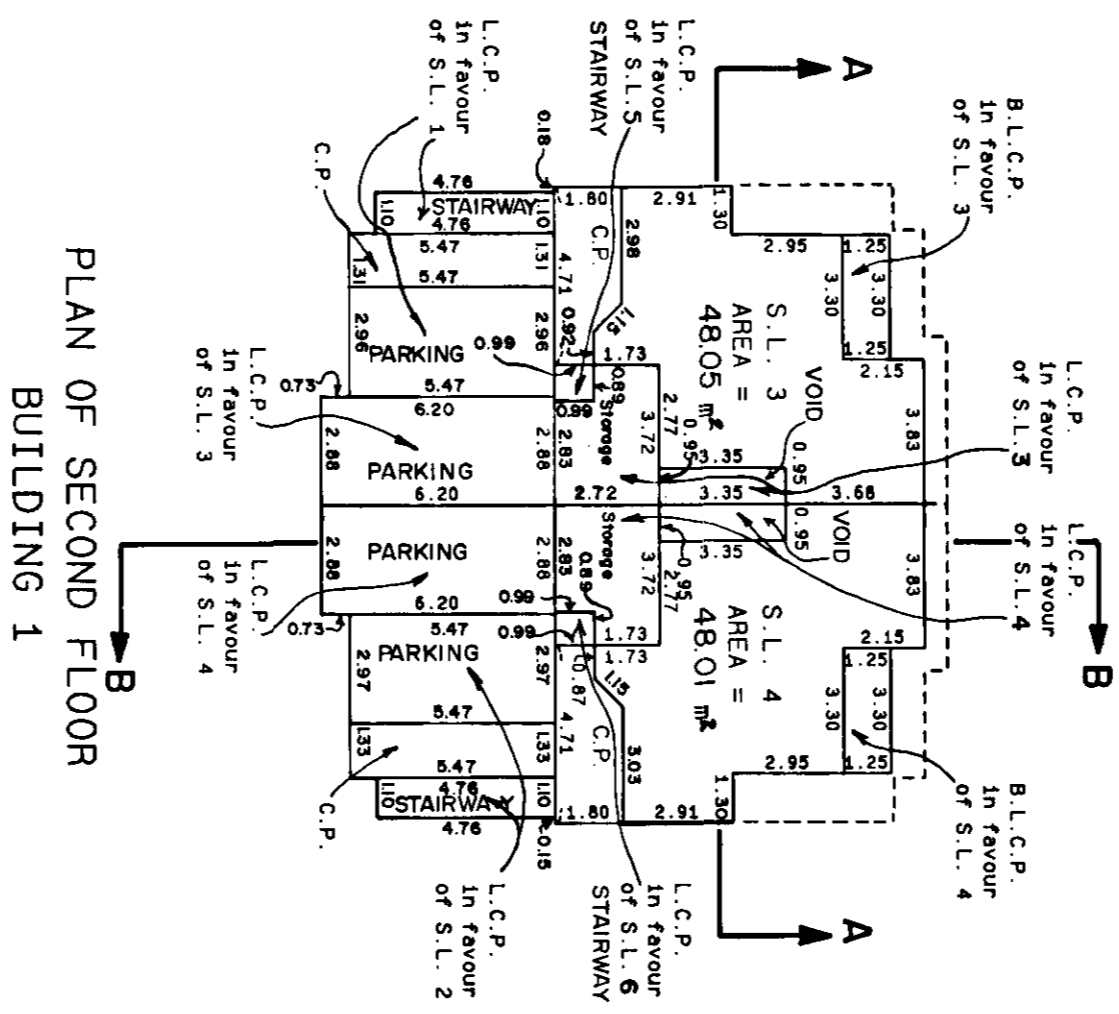
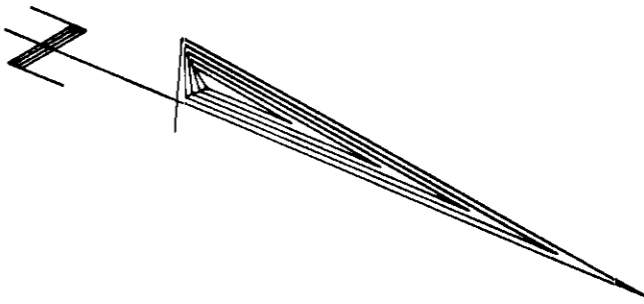
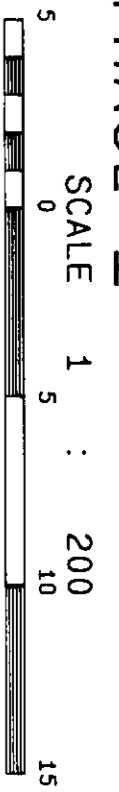

PLAN OF SECOND FLOOR  
BUILDING 1

NOTE:  
 S.L. DENOTES STRATA LOT  
 C.P. DENOTES COMMON PROPERTY  
 L.C.P. DENOTES LIMITED COMMON PROPERTY  
 C.F. DENOTES COMMON FACILITY  
 PT. DENOTES COMMON PART  
 B. DENOTES BALCONY  
 BALCONIES ARE COMMON PROPERTY AND ARE NOT INCLUDED IN SQUARE METRE (M²) AREAS  
 ALL DISTANCES ARE IN METRES.

*[Signature]*  
 B.C.L.S.  
 January 16, 1989

J88038

SP88358B

PLAN OF STRATA LOTS 5 & 6  
PHASE I  
STRATA PLAN VR 2382

SHEET 7 OF 30 SHEETS

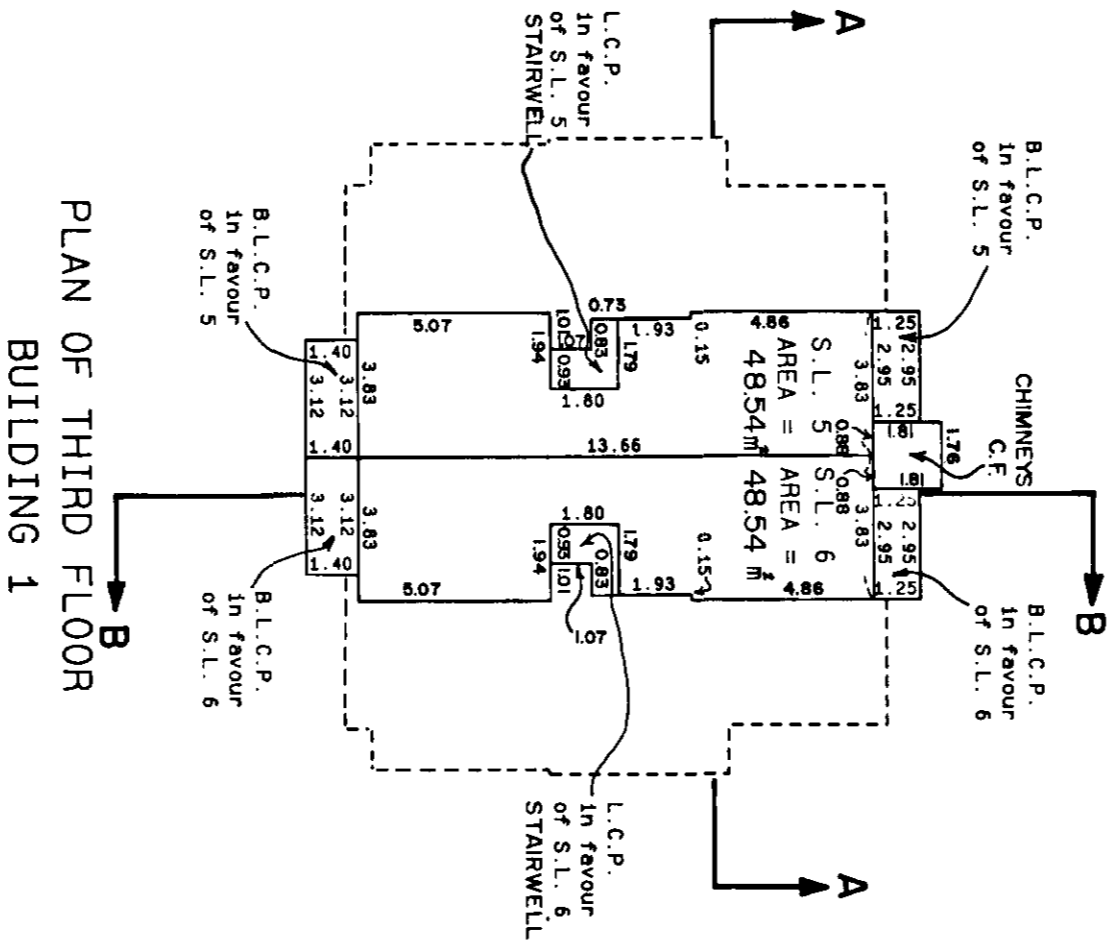
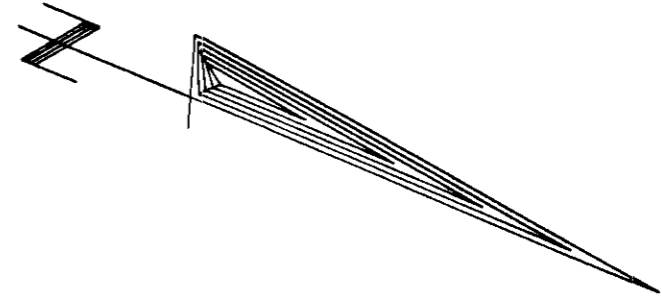
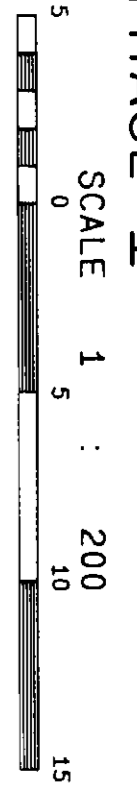

PLAN OF THIRD FLOOR  
BUILDING 1

NOTE:  
S.L. DENOTES STRATA LOT  
C.P. DENOTES COMMON PROPERTY  
L.C.P. DENOTES LIMITED COMMON PROPERTY  
C.F. DENOTES COMMON FACILITY  
PT. DENOTES PART  
B. DENOTES BALCONY  
BALCONIES ARE COMMON PROPERTY AND ARE NOT INCLUDED IN SQUARE METRE (M²) AREAS  
ALL DISTANCES ARE IN METRES.

*[Signature]*  
B.C.L.S.  
January 16, 1989

J88038

SP88358B

PLAN OF STRATA LOTS 7 & 8  
PHASE I  
STRATA PLAN VR 2382

SHEET 8 OF 30 SHEETS

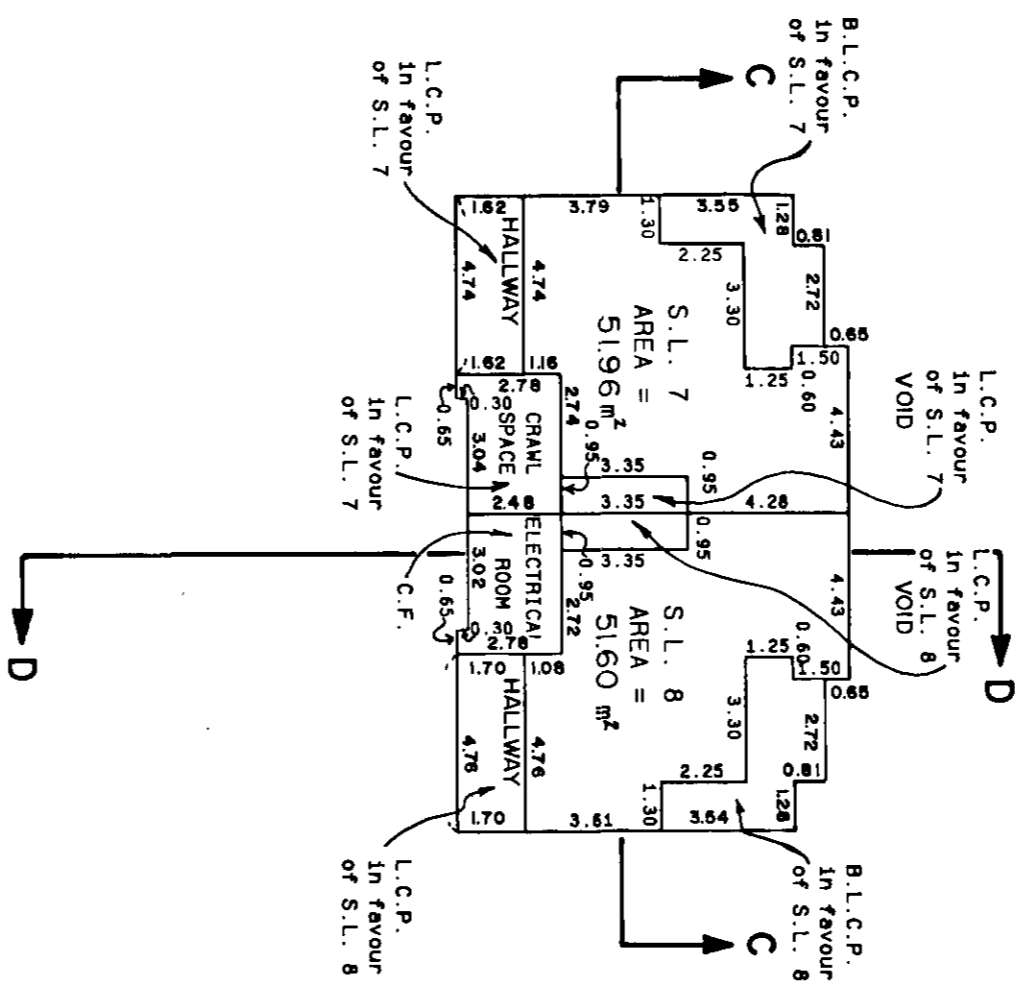
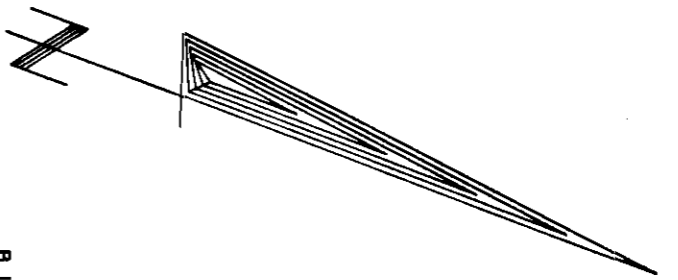
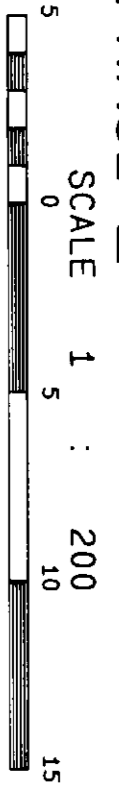

PLAN OF GROUND FLOOR  
BUILDING 2

NOTE:  
S.L. DENOTES STRATA LOT  
C.P. DENOTES COMMON PROPERTY  
L.C.P. DENOTES LIMITED COMMON PROPERTY  
C.F. DENOTES COMMON FACILITY  
PT. DENOTES COMMON PART  
B. DENOTES BALCONY  
BALCONIES ARE COMMON PROPERTY AND ARE NOT INCLUDED IN SQUARE METRE (M²) AREAS  
ALL DISTANCES ARE IN METRES.

*[Signature]*  
B.C.L.S.

January 16, 1989

J88038

SP883588



# PLAN OF STRATA LOTS 9 & 10 PHASE I

# STRATA PLAN VR 2382

SHEET 9 OF 30 SHEETS

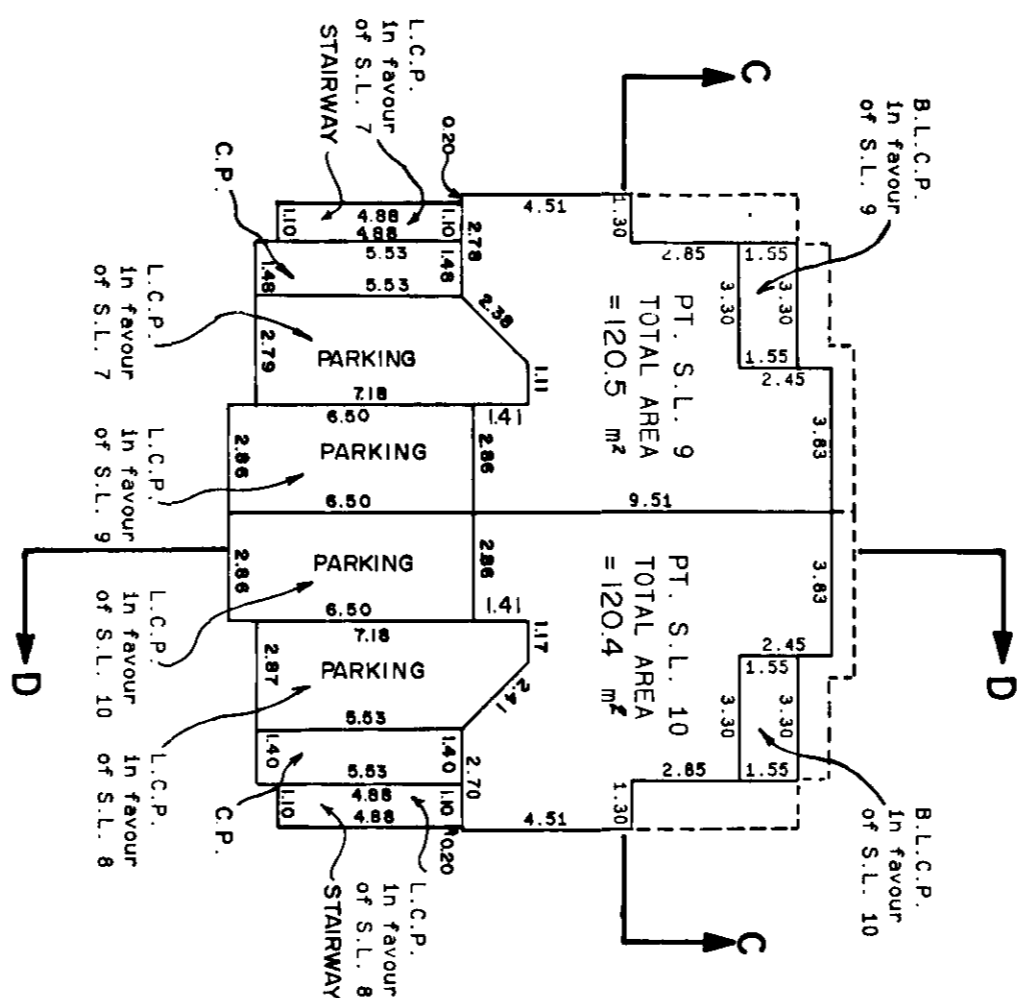
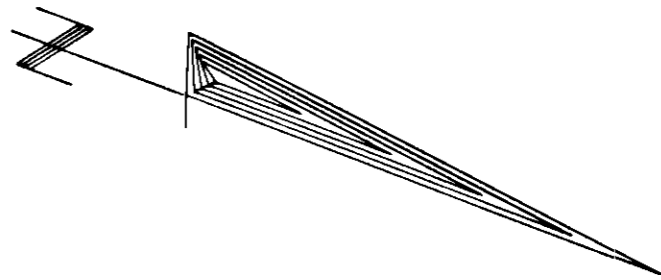
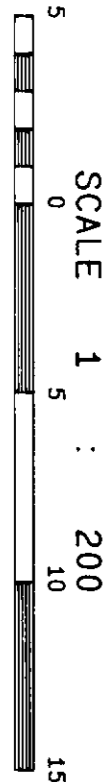

### PLAN OF SECOND FLOOR BUILDING 2

NOTE:

- S.L. DENOTES STRATA LOT
- C.P. DENOTES COMMON PROPERTY
- L.C.P. DENOTES LIMITED COMMON PROPERTY
- C.F. DENOTES COMMON FACILITY
- PT. DENOTES PART
- B. DENOTES BALCONY

BALCONIES ARE COMMON PROPERTY AND ARE NOT INCLUDED IN SQUARE METRE (M<sup>2</sup>) AREAS  
ALL DISTANCES ARE IN METRES.

B.C.L.S.

January 16, 1989

J88038

SP883588

PLAN OF STRATA LOTS 9 & 10  
PHASE I STRATA PLAN VR 2381

SHEET 10 OF 30 SHEETS

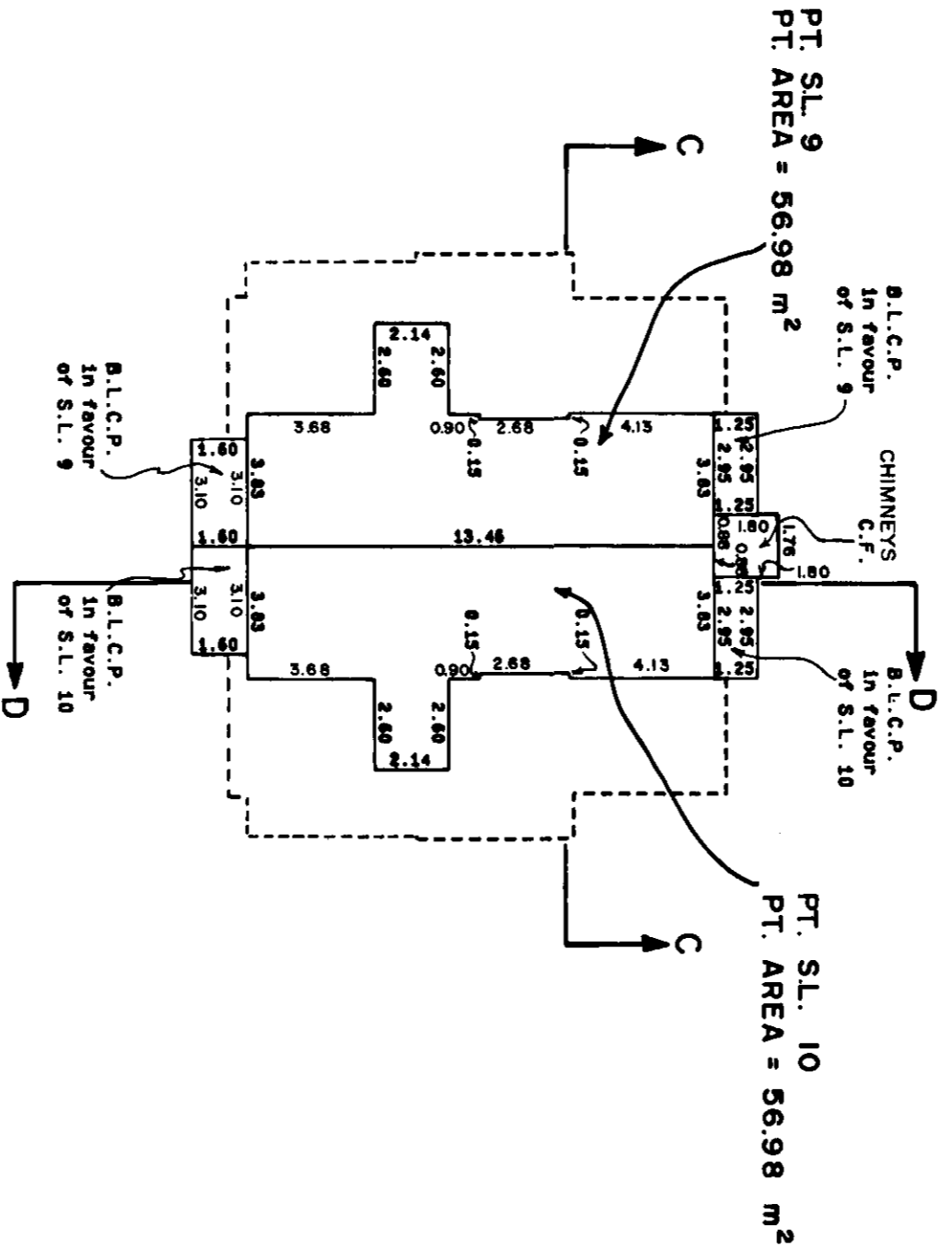
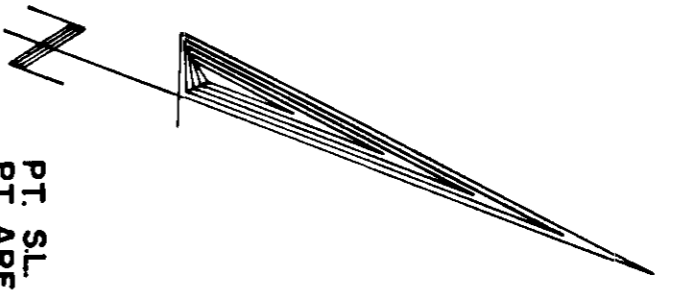
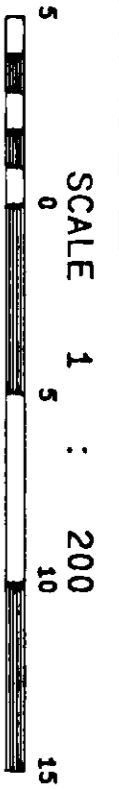

PLAN OF THIRD FLOOR  
BUILDING 2

NOTE:  
S.L. DENOTES STRATA LOT  
C.P. DENOTES COMMON PROPERTY  
L.C.P. DENOTES LIMITED COMMON PROPERTY  
C.F. DENOTES COMMON FACILITY  
PT. DENOTES COMMON PART  
B. DENOTES BALCONY  
BALCONIES ARE COMMON PROPERTY AND ARE NOT INCLUDED IN SQUARE METRE (M<sup>2</sup>) AREAS  
ALL DISTANCES ARE IN METRES.

*[Signature]*  
B.C.L.S.  
January 16, 1989

J88038

SP88358B

PLAN OF STRATA LOTS 11 & 12  
PHASE I STRATA PLAN VR 2382

SHEET 11 OF 30 SHEETS

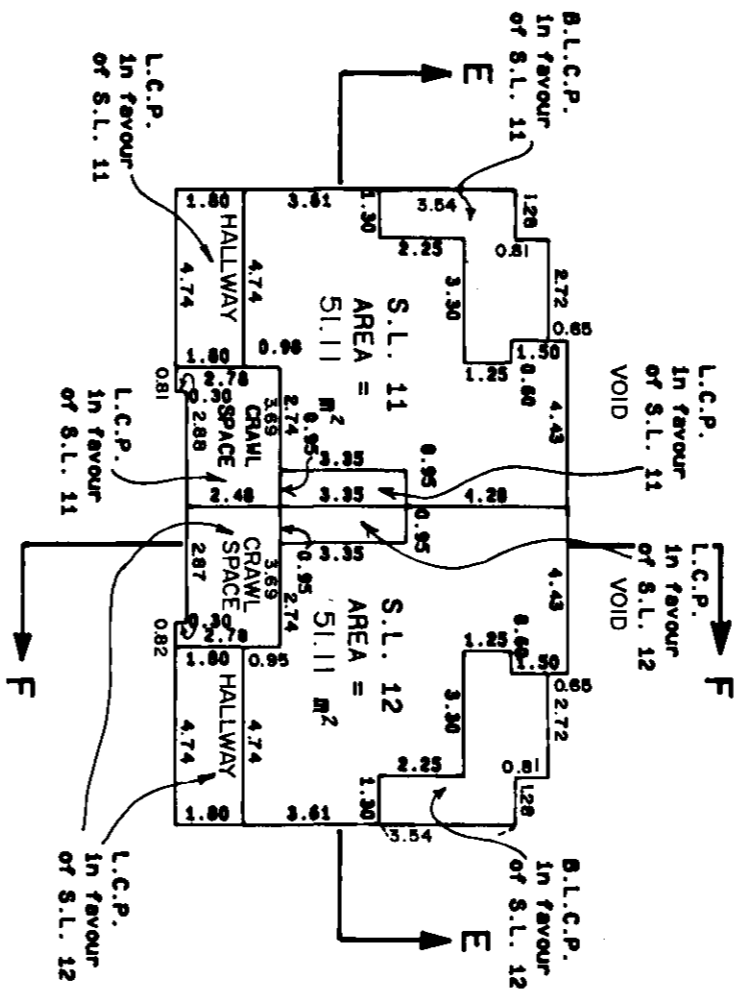
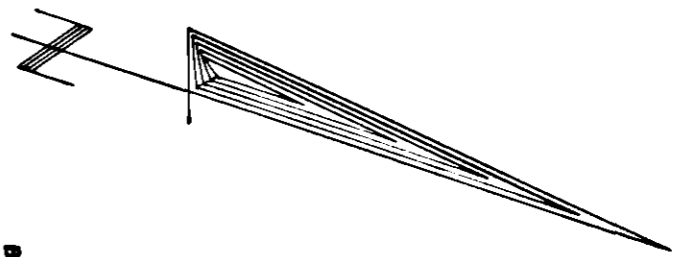

PLAN OF GROUND FLOOR  
BUILDING 3

NOTE:  
S.L. DENOTES STRATA LOT  
C.P. DENOTES COMMON PROPERTY  
L.C.P. DENOTES LIMITED COMMON PROPERTY  
C.F. DENOTES COMMON FACILITY  
PT. DENOTES COMMON PART  
B. DENOTES BALCONY  
BALCONIES ARE COMMON PROPERTY AND ARE NOT INCLUDED IN SQUARE METRE (M²) AREAS  
ALL DISTANCES ARE IN METRES.

B.C.L.S.

January 16, 1989

J88038

SP88358B

# PLAN OF STRATA LOTS 13 & 14 PHASE I

# STRATA PLAN VR 2382

SHEET 12 OF 30 SHEETS

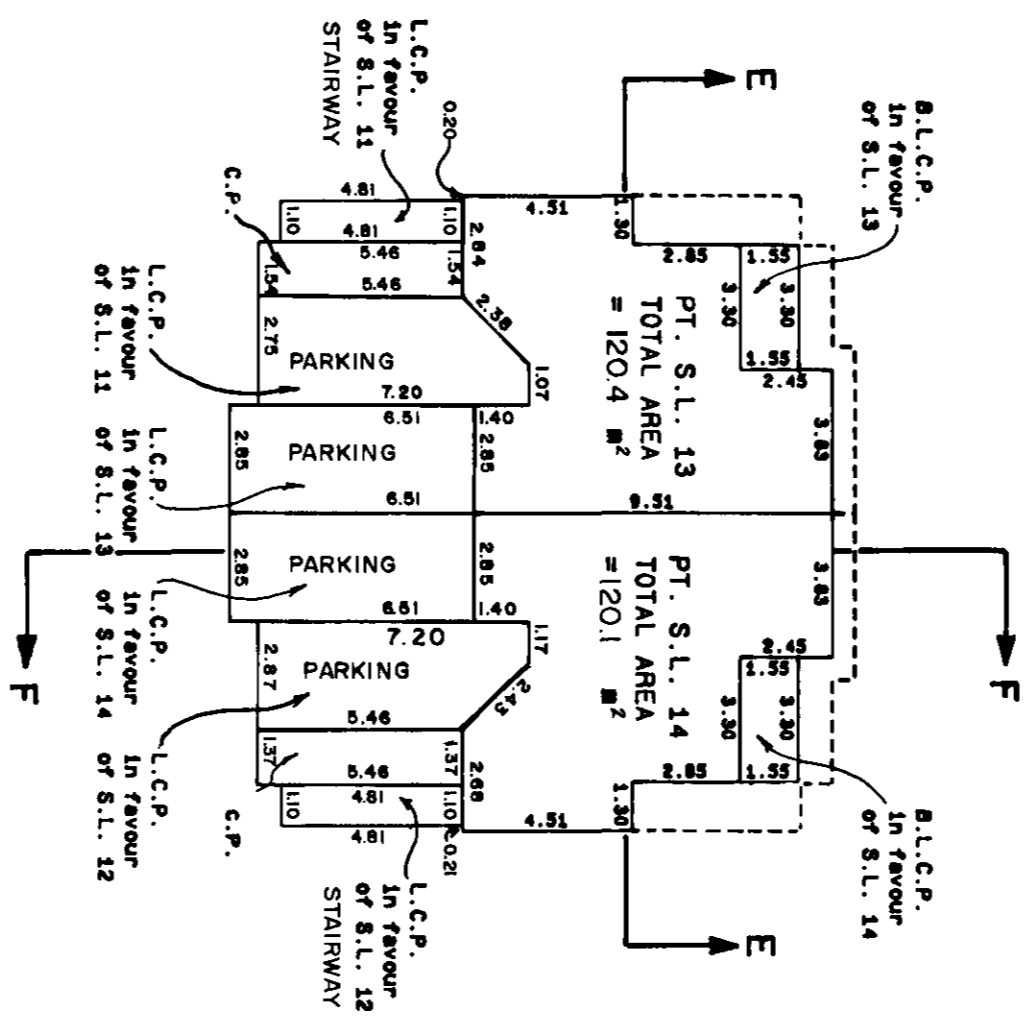
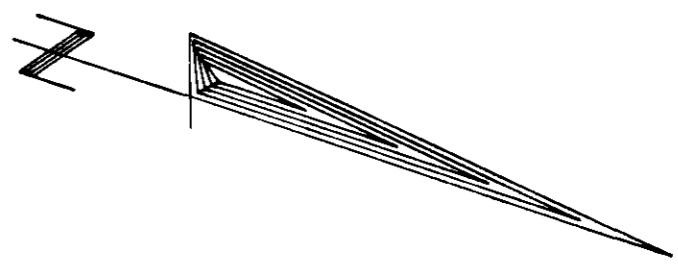

### PLAN OF SECOND FLOOR BUILDING 3

NOTE:

- S.L. DENOTES STRATA LOT
- C.P. DENOTES COMMON PROPERTY
- L.C.P. DENOTES LIMITED COMMON PROPERTY
- C.F. DENOTES COMMON FACILITY
- PT. DENOTES COMMON PART
- B. DENOTES BALCONY

BALCONIES ARE COMMON PROPERTY AND ARE NOT INCLUDED IN SQUARE METRE (M<sup>2</sup>) AREAS  
ALL DISTANCES ARE IN METRES.

*[Signature]*  
B.C.L.S.  
January 16, 1989

J88038

SP883588

PLAN OF STRATA LOTS 13 & 14  
PHASE I STRATA PLAN VR 2382

SHEET 13 OF 30 SHEETS

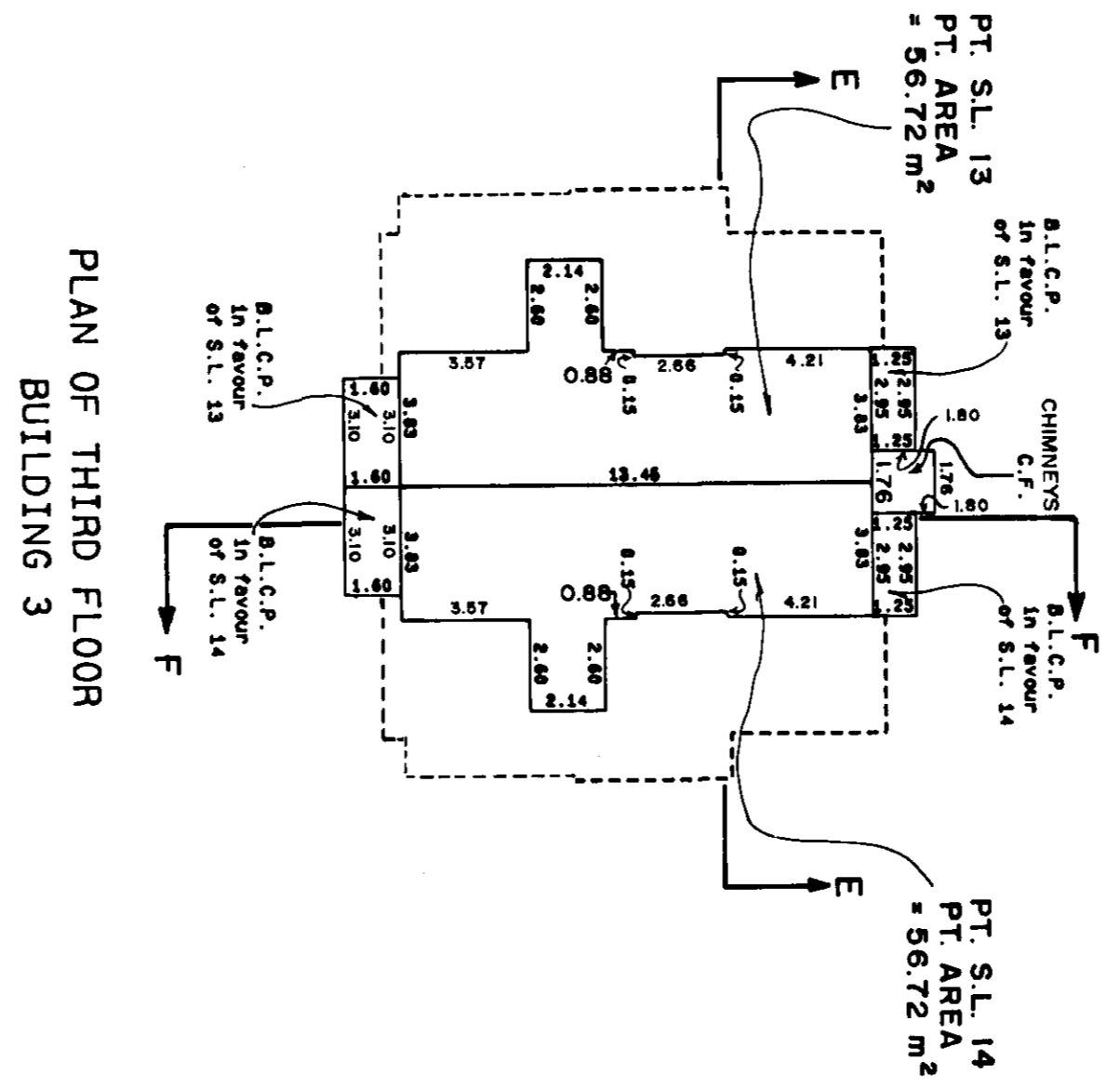
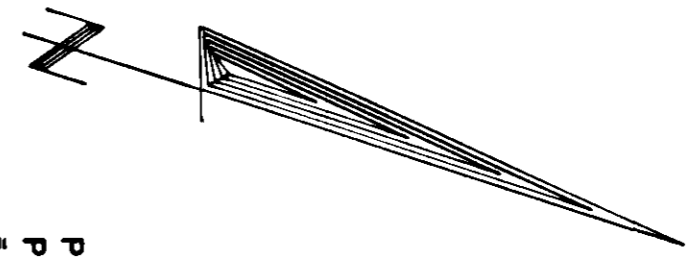

PLAN OF THIRD FLOOR  
BUILDING 3

NOTE:  
S.L. DENOTES STRATA LOT  
C.P. DENOTES COMMON PROPERTY  
L.C.P. DENOTES LIMITED COMMON PROPERTY  
C.F. DENOTES COMMON FACILITY  
PT. DENOTES PART  
B. DENOTES BALCONY  
BALCONIES ARE COMMON PROPERTY AND ARE NOT INCLUDED IN SQUARE METRE (M<sup>2</sup>) AREAS  
ALL DISTANCES ARE IN METRES.

*[Signature]*  
B.C.L.S.  
January 16, 1989

J88038

SP88358B

PLAN OF STRATA LOTS 15 & 16  
PHASE I  
STRATA PLAN VR 2382

SHEET 14 OF 30 SHEETS

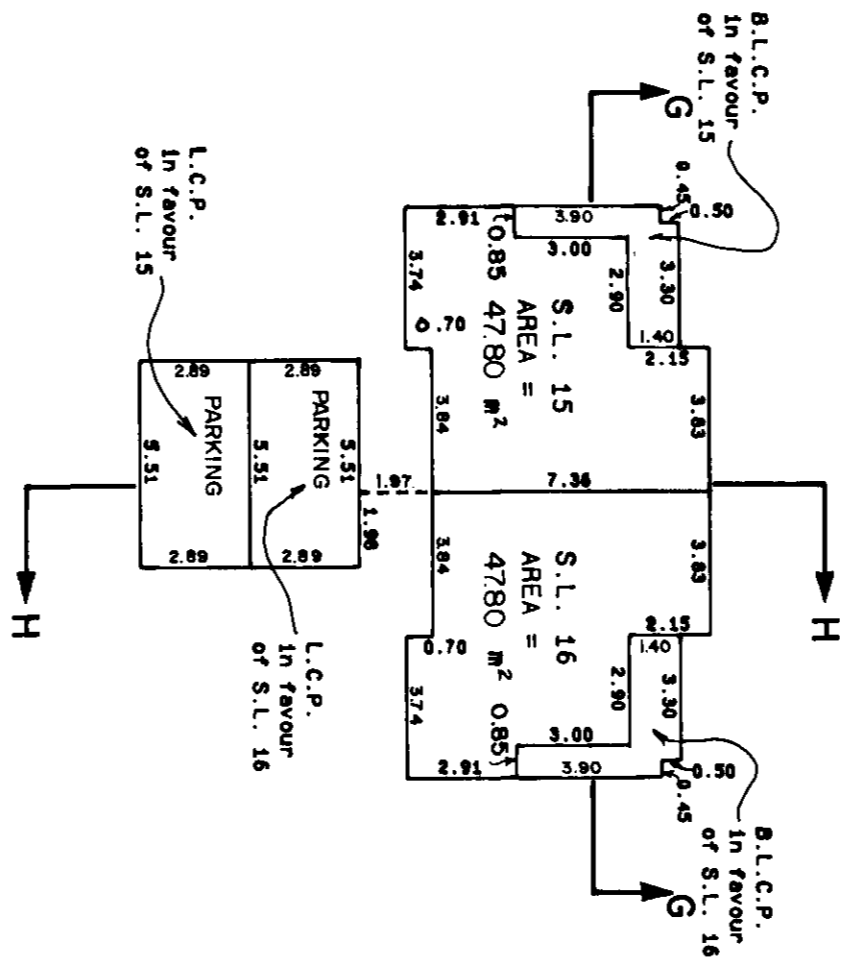
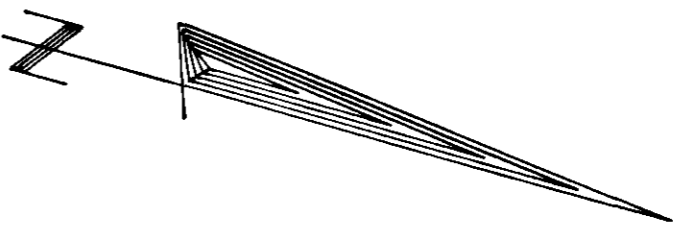
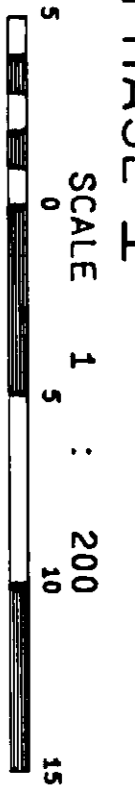

PLAN OF GROUND FLOOR  
BUILDING 4

NOTE:  
S.L. DENOTES STRATA LOT  
C.P. DENOTES COMMON PROPERTY  
L.C.P. DENOTES LIMITED COMMON PROPERTY  
C.F. DENOTES COMMON FACILITY  
PT. DENOTES PART  
B. DENOTES BALCONY  
BALCONIES ARE COMMON PROPERTY AND ARE NOT INCLUDED IN SQUARE METRE (M<sup>2</sup>) AREAS  
ALL DISTANCES ARE IN METRES.

*[Signature]*  
B.C.L.S.  
January 16, 1989

J88038

SP883588

PLAN OF STRATA LOTS 17 & 18  
PHASE I STRATA PLAN VR 2382

SHEET 15 OF 30 SHEETS

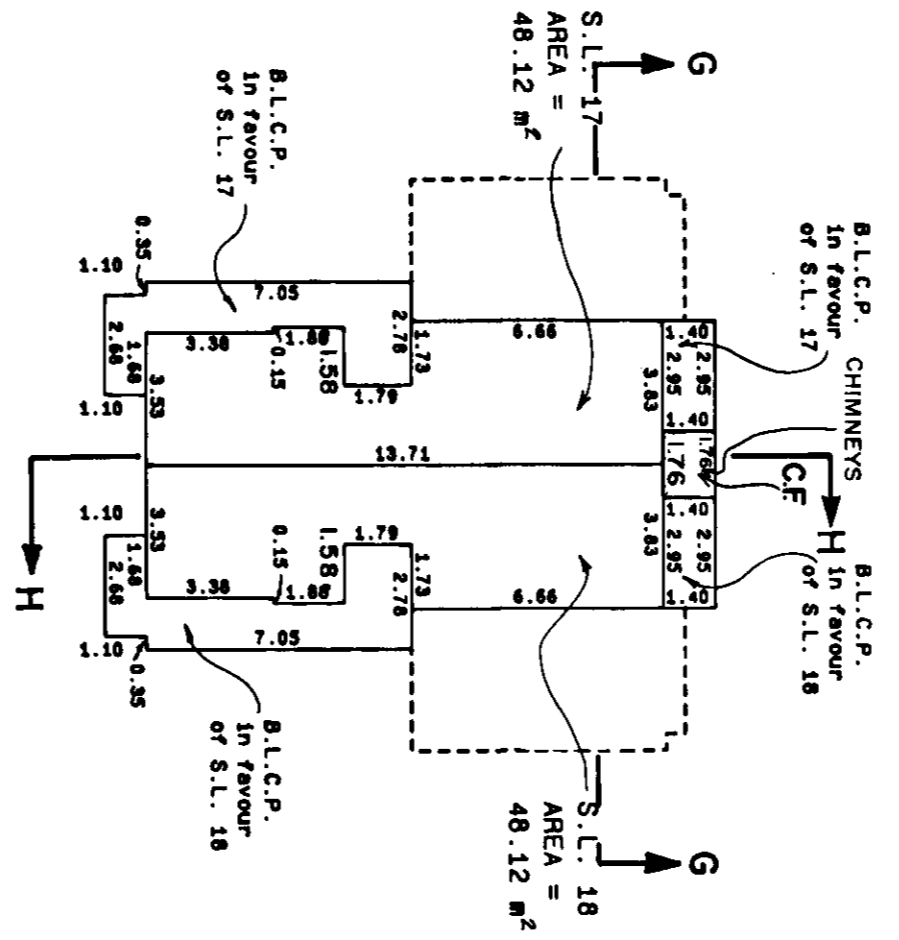
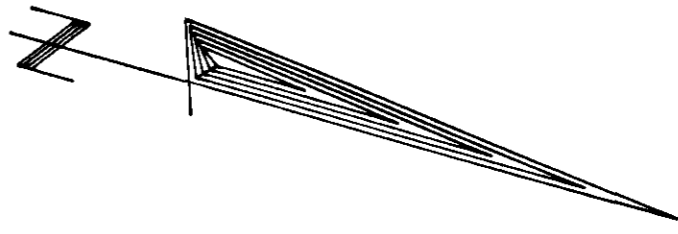
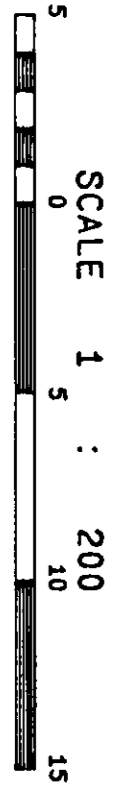

PLAN OF SECOND FLOOR  
BUILDING 4

- NOTE:
- S.L. DENOTES STRATA LOT
  - C.P. DENOTES COMMON PROPERTY
  - L.C.P. DENOTES LIMITED COMMON PROPERTY
  - C.F. DENOTES COMMON FACILITY
  - PT. DENOTES PART
  - B. DENOTES BALCONY
- BALCONIES ARE COMMON PROPERTY AND ARE NOT INCLUDED IN SQUARE METRE (M²) AREAS  
ALL DISTANCES ARE IN METRES.

*BB*  
B.C.L.S.

January 16, 1989

J88038

SP88358B

PLAN OF STRATA LOTS 19-22  
PHASE I

STRATA PLAN VR 2382

SHEET 16 OF 30 SHEETS

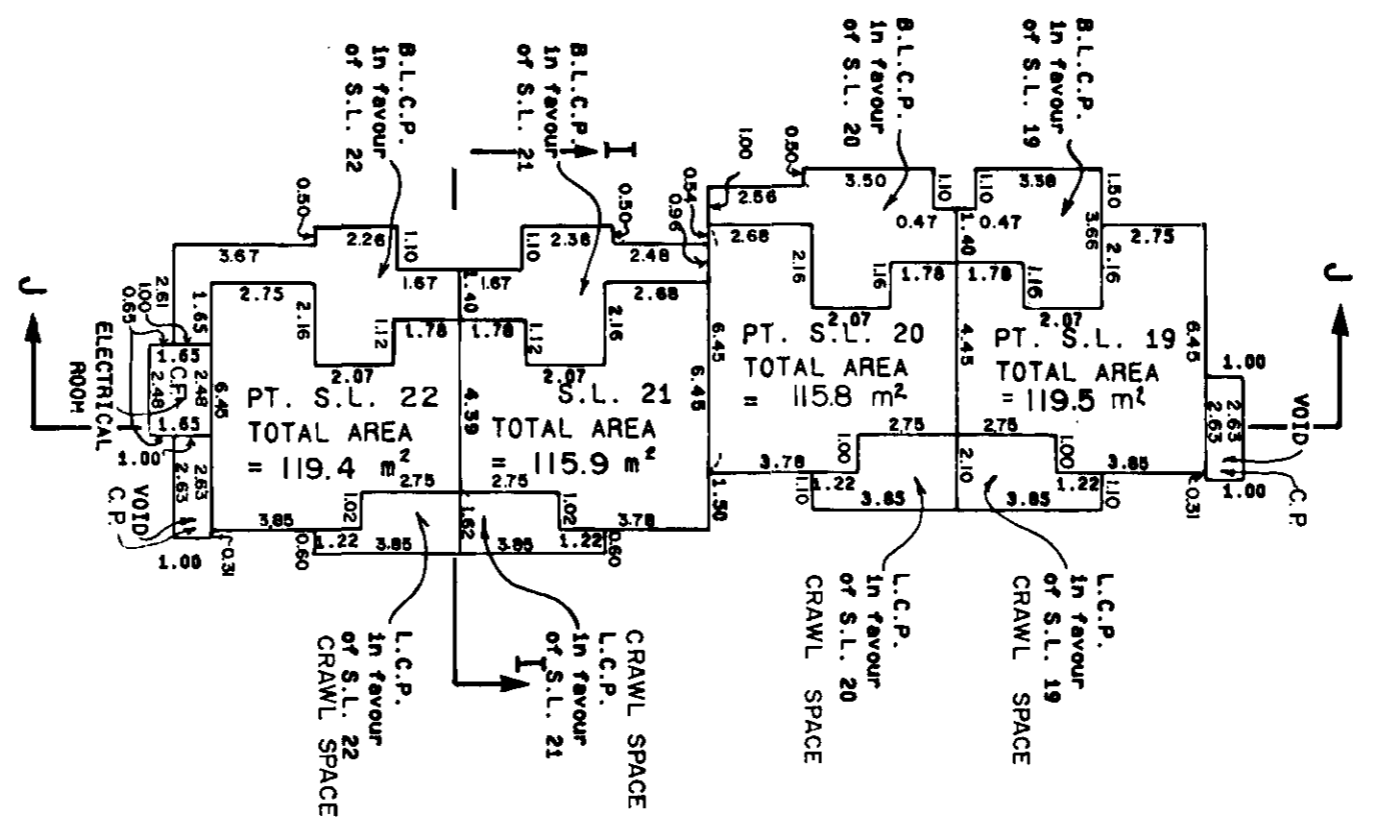
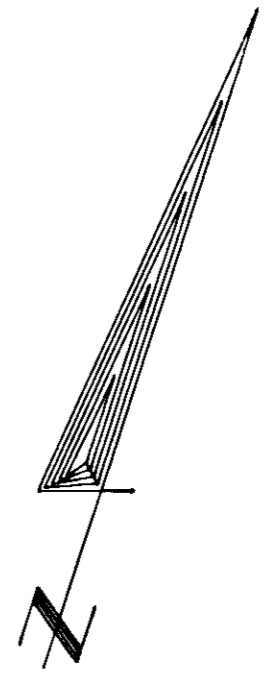
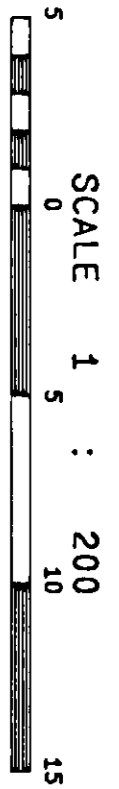

PLAN OF GROUND FLOOR  
BUILDING 5

NOTE:  
S.L. DENOTES STRATA LOT  
C.P. DENOTES COMMON PROPERTY  
L.C.P. DENOTES LIMITED COMMON PROPERTY  
C.F. DENOTES COMMON FACILITY  
PT. DENOTES PART  
B. DENOTES BALCONY  
BALCONIES ARE COMMON PROPERTY AND ARE NOT INCLUDED IN SQUARE METRE (M<sup>2</sup>) AREAS  
ALL DISTANCES ARE IN METRES.

*BB*  
B.C.L.S.

January 16, 1989

J88038

SP883588



PLAN OF STRATA LOTS 19-22  
PHASE I

STRATA PLAN VR 2382

SHEET 17 OF 30 SHEETS

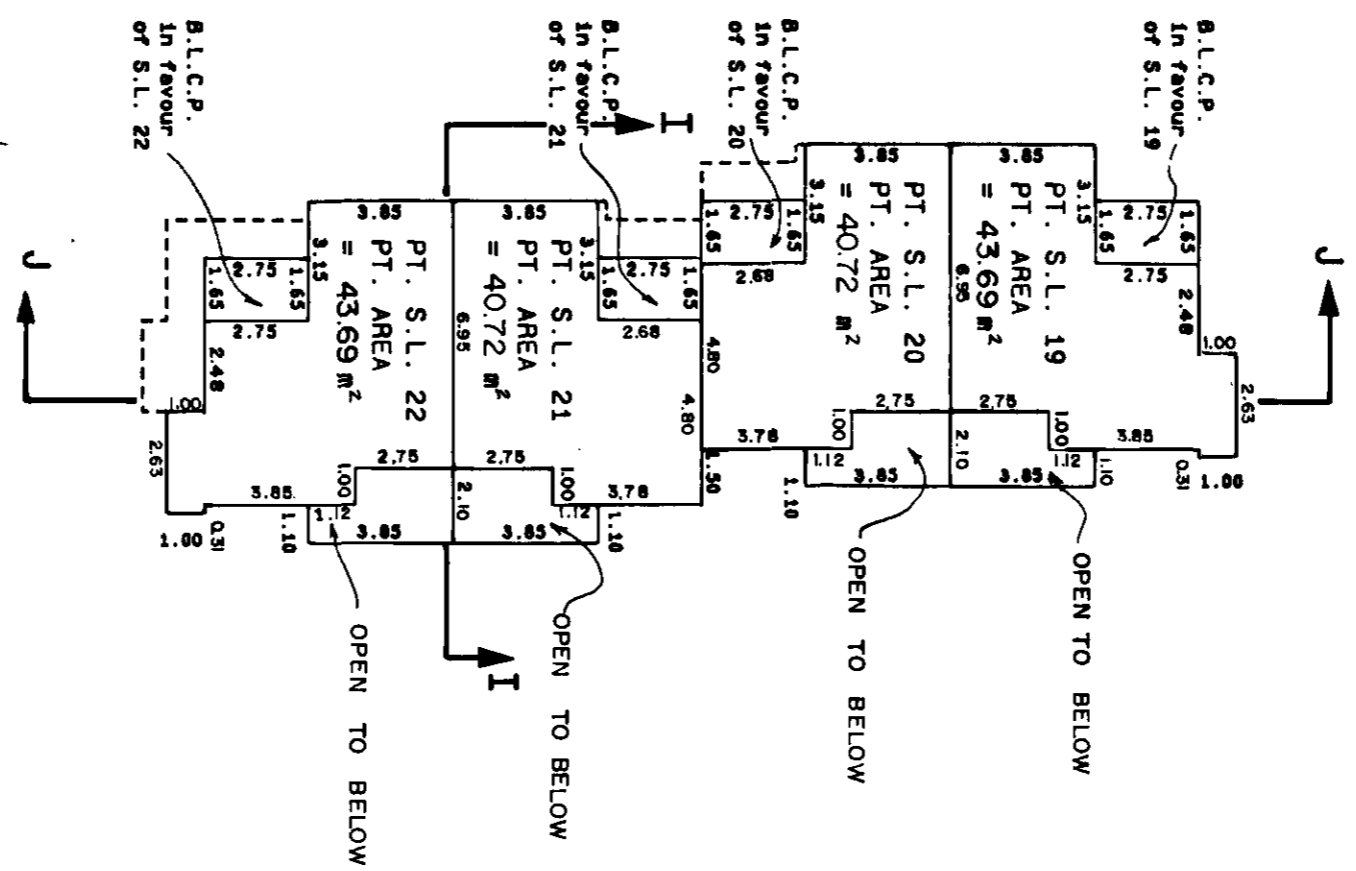
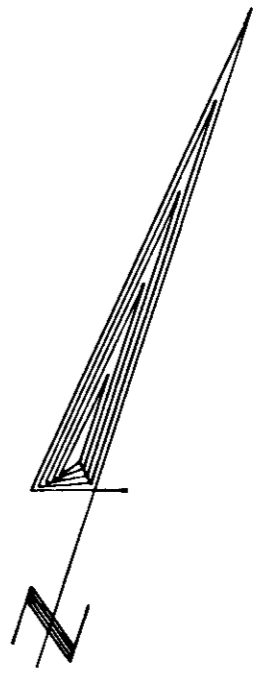
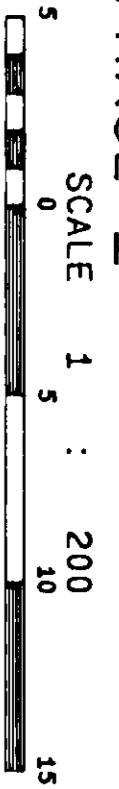

PLAN OF SECOND FLOOR  
BUILDING 5

NOTE:  
S.L. DENOTES STRATA LOT  
C.P. DENOTES COMMON PROPERTY  
L.C.P. DENOTES LIMITED COMMON PROPERTY  
C.F. DENOTES COMMON FACILITY  
PT. DENOTES PART  
B. DENOTES BALCONY  
BALCONIES ARE COMMON PROPERTY AND ARE NOT INCLUDED IN SQUARE METRE (M²) AREAS  
ALL DISTANCES ARE IN METRES.

*BB*  
B.C.L.S.

January 16, 1989

J88038

SP88358B

PLAN OF STRATA LOTS 19-22  
PHASE I

STRATA PLAN VR 2382

SHEET 18 OF 30 SHEETS

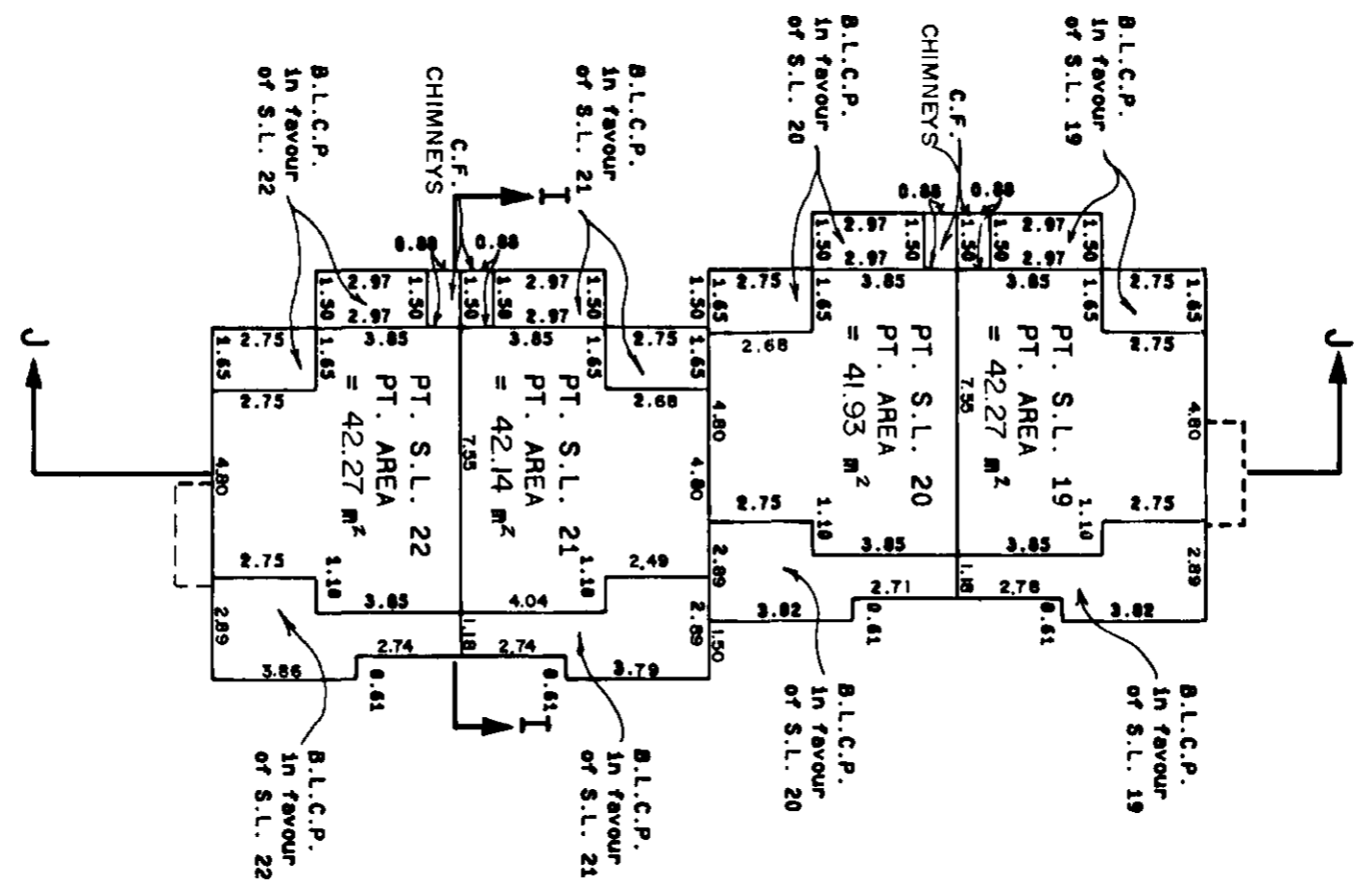
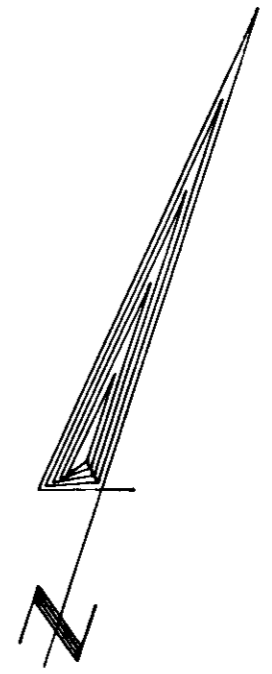
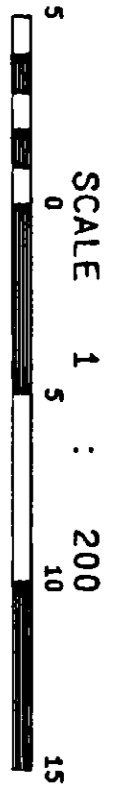

PLAN OF THIRD FLOOR  
BUILDING 5

NOTE:  
S.L. DENOTES STRATA LOT  
C.P. DENOTES COMMON PROPERTY  
L.C.P. DENOTES LIMITED COMMON PROPERTY  
C.F. DENOTES COMMON FACILITY  
PT. DENOTES PART  
B. DENOTES BALCONY  
BALCONIES ARE COMMON PROPERTY AND ARE NOT INCLUDED IN SQUARE METRE (M<sup>2</sup>) AREAS  
ALL DISTANCES ARE IN METRES.

*BB*  
B.C.L.S.  
January 16, 1989

J86038

SP88358B

# PLAN OF STRATA LOTS 23-26 PHASE I

# STRATA PLAN VR 2382

SHEET 19 OF 30 SHEETS

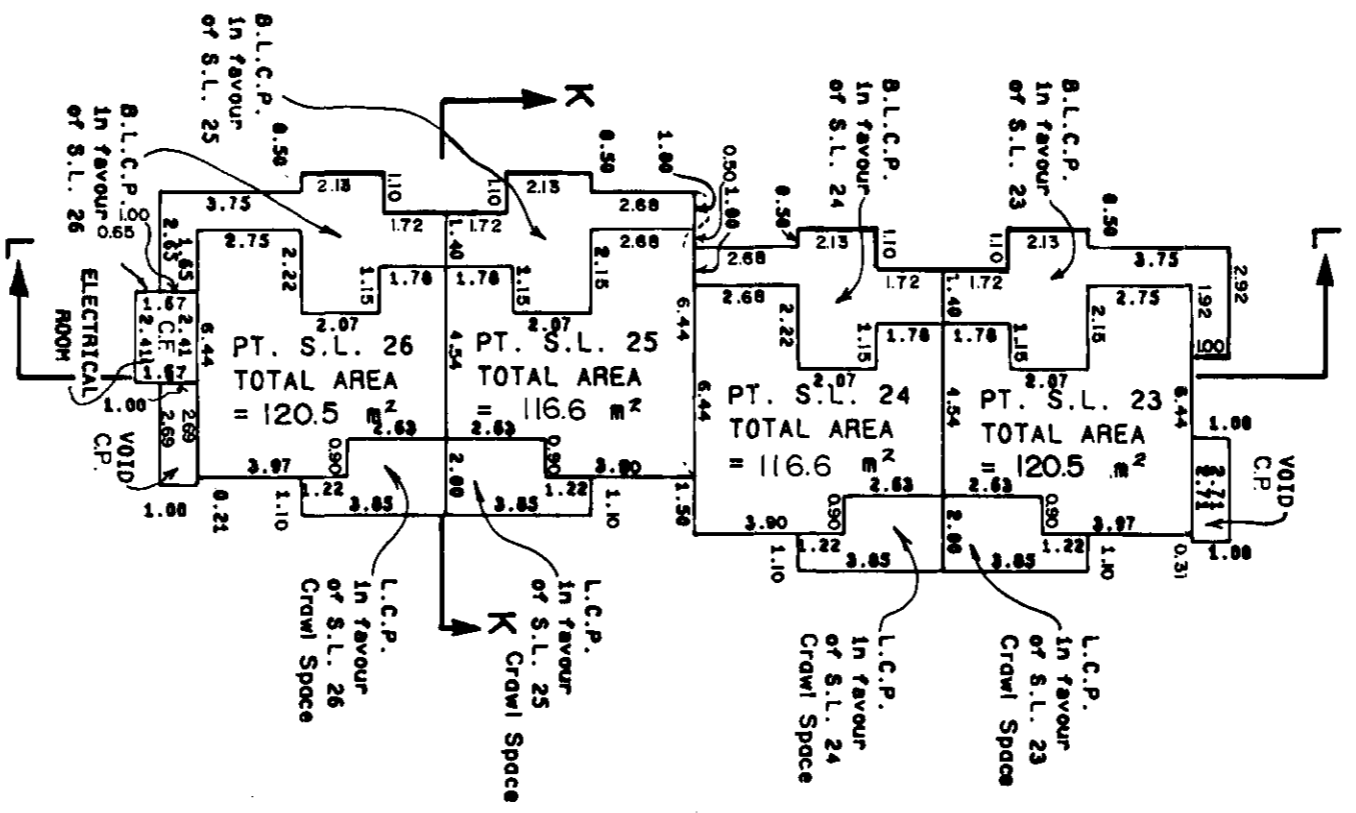
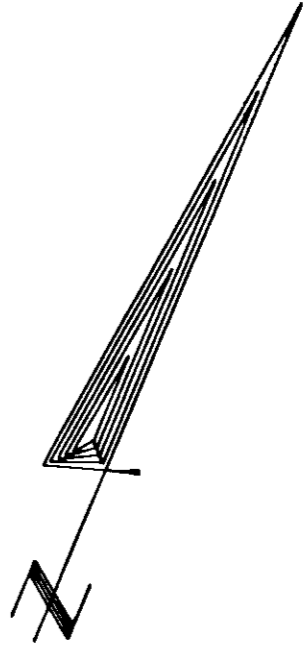
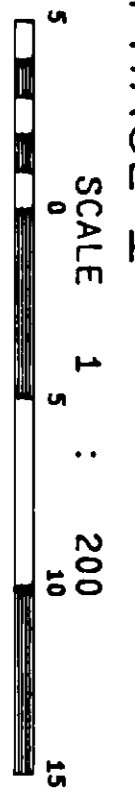

## PLAN OF GROUND FLOOR BUILDING 6

NOTE:

- S.L. DENOTES STRATA LOT
- C.P. DENOTES COMMON PROPERTY
- L.C.P. DENOTES LIMITED COMMON PROPERTY
- C.F. DENOTES COMMON FACILITY
- PT. DENOTES PART
- B. DENOTES BALCONY

BALCONIES ARE COMMON PROPERTY AND ARE NOT INCLUDED IN SQUARE METRE (M<sup>2</sup>) AREAS  
ALL DISTANCES ARE IN METRES.

*[Signature]*  
B.C.L.S.

January 16, 1989

J88038

SP88358B

PLAN OF STRATA LOTS 23-26  
PHASE I

STRATA PLAN VR 2382

SHEET 20 OF 30 SHEETS

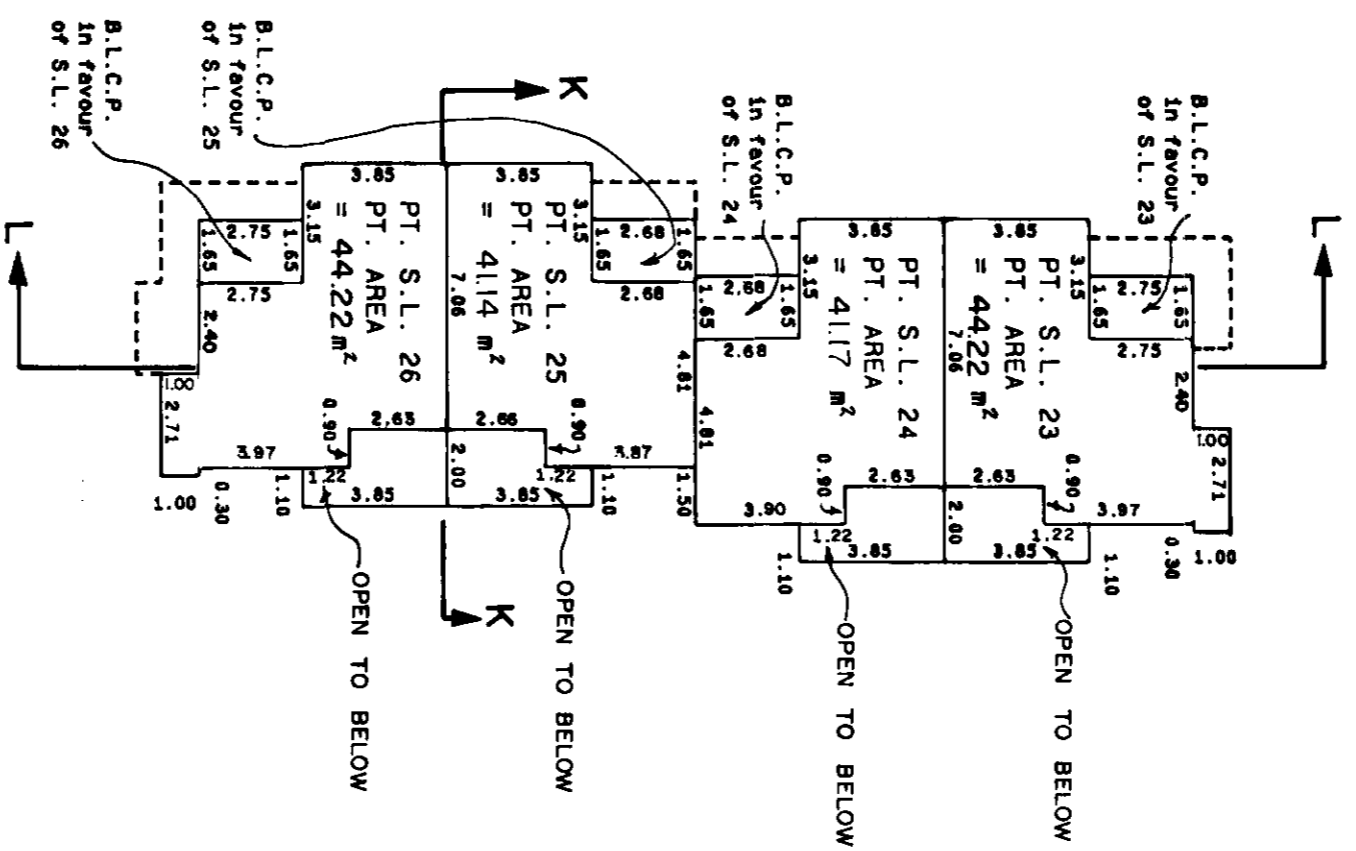
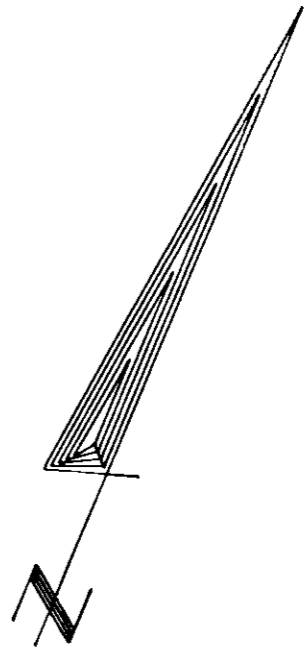
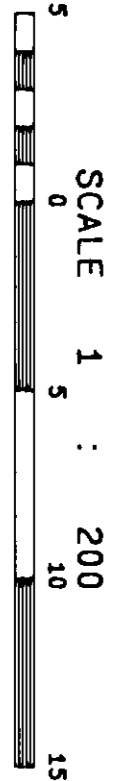

PLAN OF SECOND FLOOR  
BUILDING 6

NOTE:  
S.L. DENOTES STRATA LOT  
C.P. DENOTES COMMON PROPERTY  
L.C.P. DENOTES LIMITED COMMON PROPERTY  
C.F. DENOTES COMMON FACILITY  
PT. DENOTES PART  
B. DENOTES BALCONY  
BALCONIES ARE COMMON PROPERTY AND ARE NOT INCLUDED IN SQUARE METRE (M<sup>2</sup>) AREAS  
ALL DISTANCES ARE IN METRES.

*BB*  
B.C.L.S.

January 16, 1989

J88038

SP883588

PLAN OF STRATA LOTS 23-26  
PHASE I

STRATA PLAN VR 2382

SHEET 21 OF 30 SHEETS

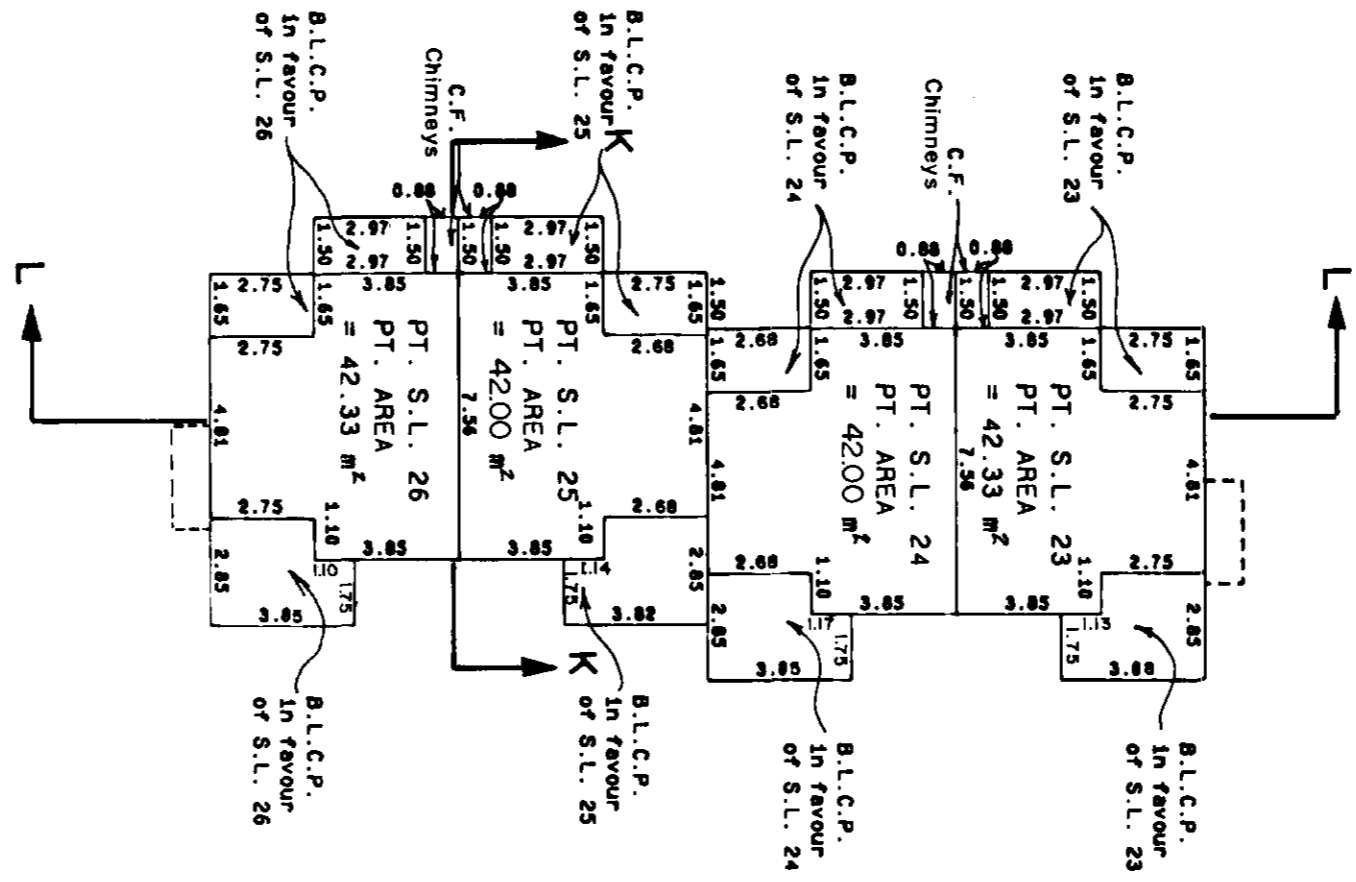
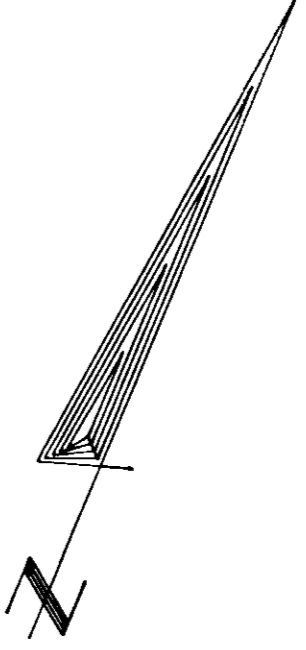

PLAN OF THIRD FLOOR  
BUILDING 6

NOTE:  
S.L. DENOTES STRATA LOT  
C.P. DENOTES COMMON PROPERTY  
L.C.P. DENOTES LIMITED COMMON PROPERTY  
C.F. DENOTES COMMON FACILITY  
PT. DENOTES PART  
B. DENOTES BALCONY  
BALCONIES ARE COMMON PROPERTY AND ARE NOT INCLUDED IN SQUARE METRE (M<sup>2</sup>) AREAS  
ALL DISTANCES ARE IN METRES.

B.C.L.S.

January 16

1989

J88038

SP88358B

# CROSS-SECTIONS PHASE I

## STRATA PLAN VR 2382

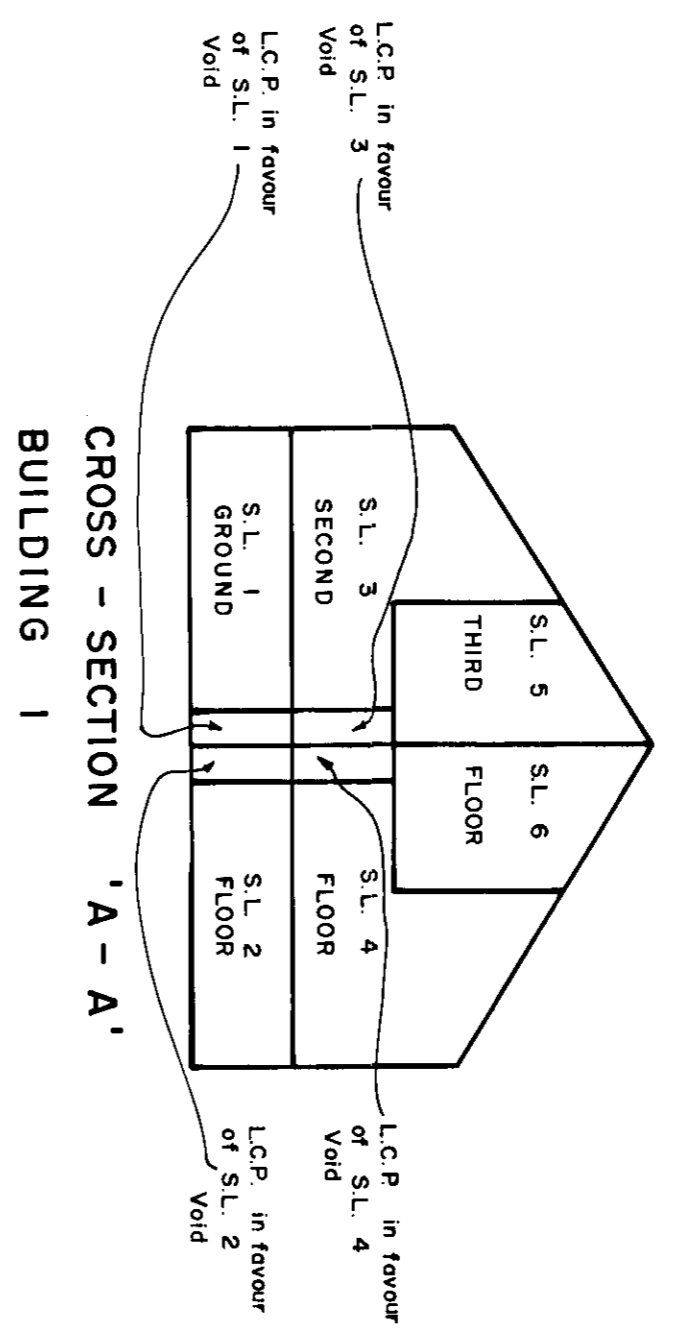
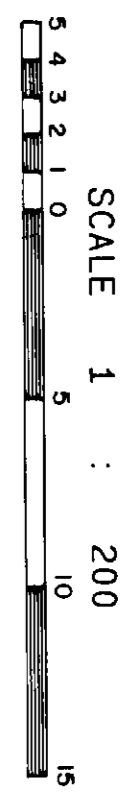

CROSS - SECTION 'A - A'  
BUILDING 1

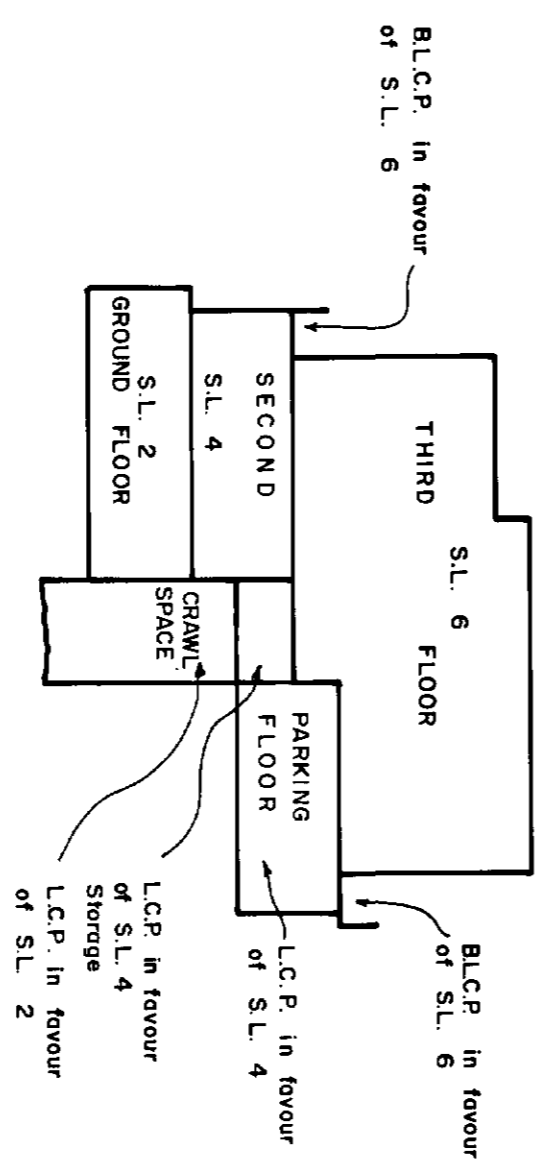

CROSS - SECTION 'B - B'  
BUILDING 1

NOTE:

- S.L. DENOTES STRATA LOT
- C.P. DENOTES COMMON PROPERTY
- L.C.P. DENOTES LIMITED COMMON PROPERTY
- C.F. DENOTES COMMON FACILITY
- PT. DENOTES PART
- B. DENOTES BALCONY

BALCONIES ARE COMMON PROPERTY AND ARE NOT INCLUDED IN SQUARE METRE (M<sup>2</sup>) AREAS  
ALL DISTANCES ARE IN METRES.

*BB*  
January 16, 1989  
B.C.L.S.

J68038

SP88358B

# CROSS-SECTIONS PHASE I

# STRATA PLAN VR 2382

SCALE 1 : 200

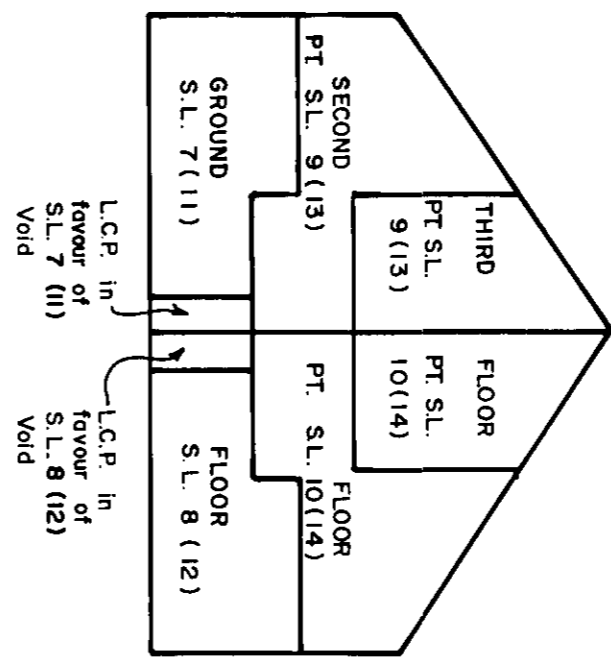

CROSS - SECTION 'C - C' (E - E)  
BUILDING 2 (3)

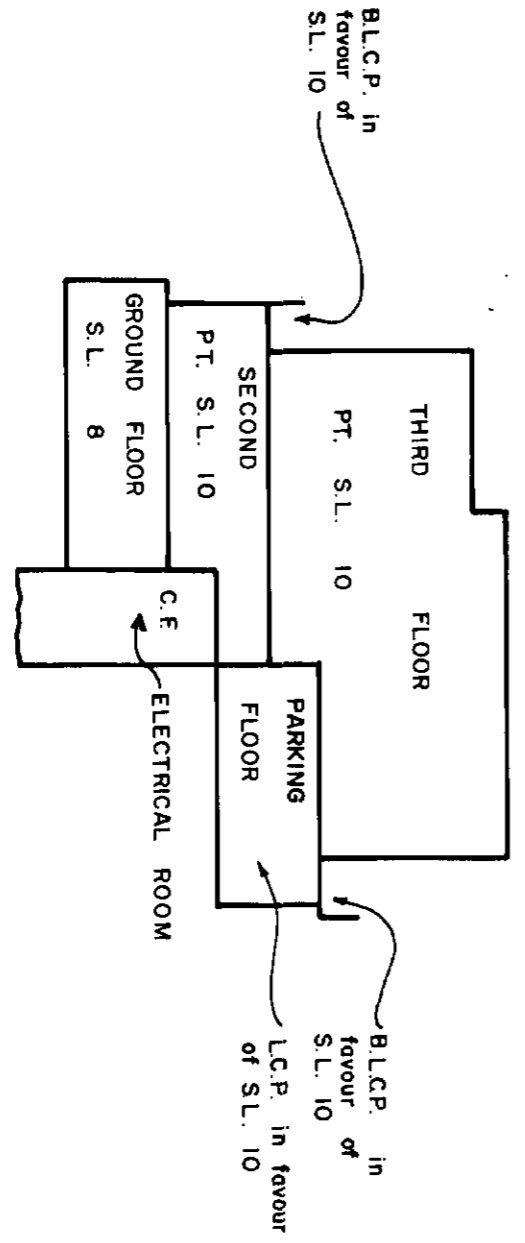

CROSS - SECTION 'D - D'  
BUILDING 2

NOTE:  
 S.L. DENOTES STRATA LOT  
 C.P. DENOTES COMMON PROPERTY  
 L.C.P. DENOTES LIMITED COMMON PROPERTY  
 C.F. DENOTES COMMON FACILITY  
 PT. DENOTES PART  
 B. DENOTES BALCONY  
 BALCONIES ARE COMMON PROPERTY AND ARE NOT INCLUDED IN SQUARE METRE (M<sup>2</sup>) AREAS  
 ALL DISTANCES ARE IN METRES.

*BB*

*January 16,*

B.C.L.S.  
1989

J88036

SP883588

# CROSS-SECTIONS PHASE I

# STRATA PLAN VR 2382

SHEET 24 OF 30 SHEETS

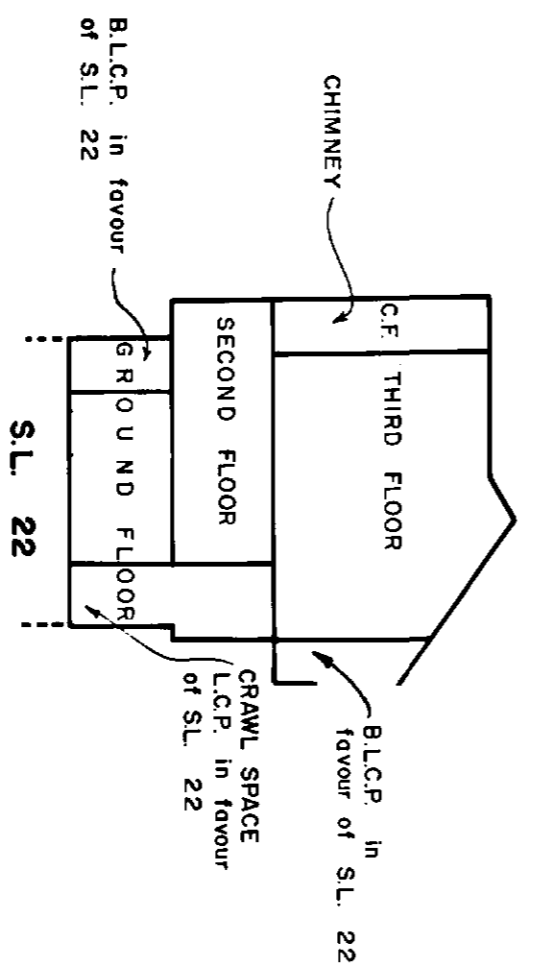
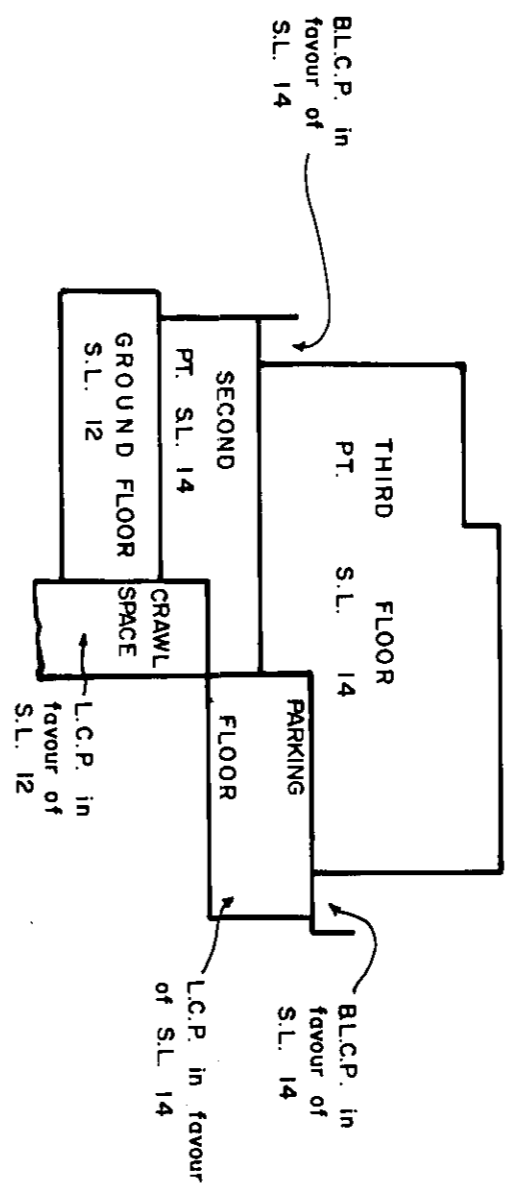
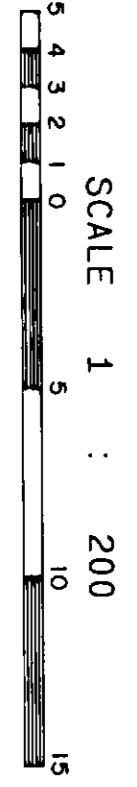

NOTE:  
 S.L. DENOTES STRATA LOT  
 C.P. DENOTES COMMON PROPERTY  
 L.C.P. DENOTES LIMITED COMMON PROPERTY  
 C.F. DENOTES COMMON FACILITY  
 PT. DENOTES COMMON PART  
 B. DENOTES BALCONY  
 BALCONIES ARE COMMON PROPERTY AND ARE NOT INCLUDED IN SQUARE METRE (M<sup>2</sup>) AREAS  
 ALL DISTANCES ARE IN METRES.

*BB*  
 B.C.L.S.  
 January 16, 1989

J88038

SP88358B



# CROSS-SECTIONS PHASE I

# STRATA PLAN VR 2382

SHEET 25 OF 30 SHEETS

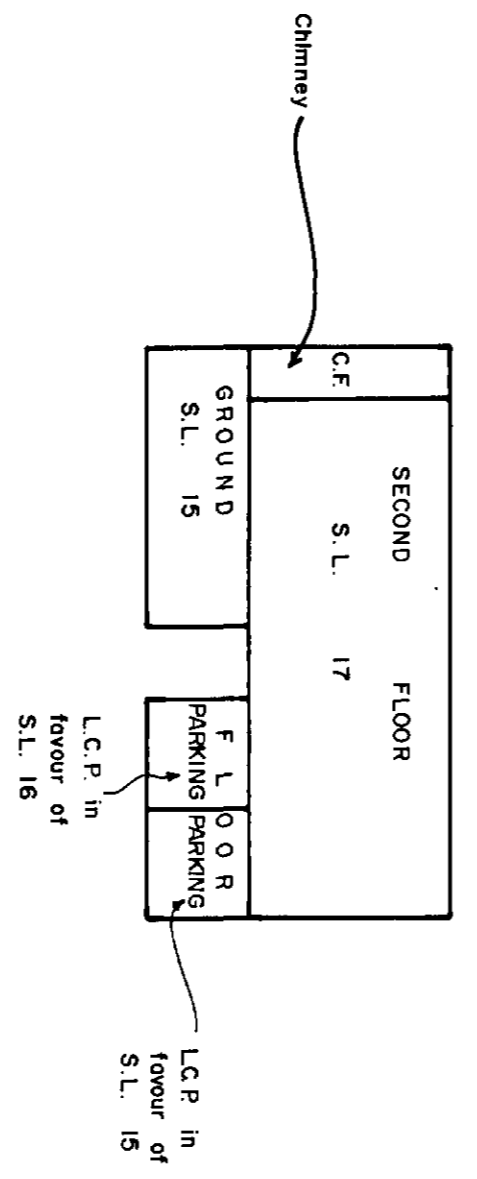
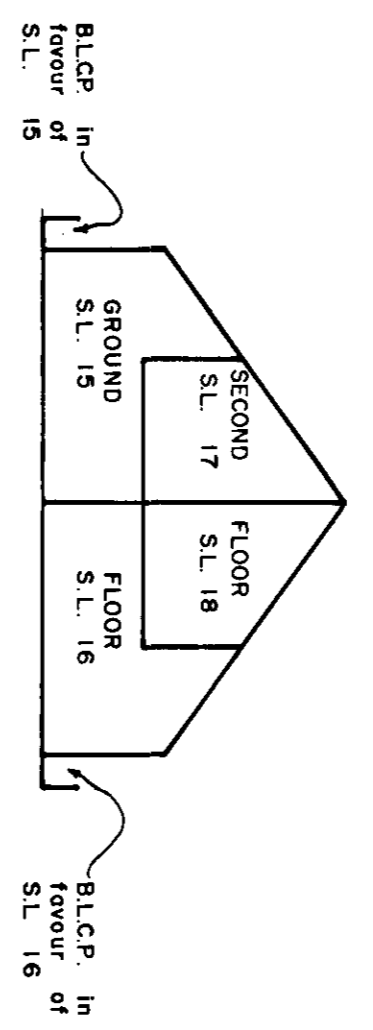
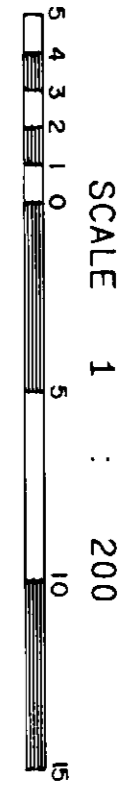

NOTE:

- S.L. DENOTES STRATA LOT
- C.P. DENOTES COMMON PROPERTY
- L.C.P. DENOTES LIMITED COMMON PROPERTY
- C.F. DENOTES COMMON FACILITY
- PT. DENOTES PART
- B. DENOTES BALCONY

BALCONIES ARE COMMON PROPERTY AND ARE NOT INCLUDED IN SQUARE METRE (M<sup>2</sup>) AREAS  
ALL DISTANCES ARE IN METRES.

*BB*  
January 16, 1989  
B.C.L.S.

J68038

SP88358B

# CROSS-SECTIONS PHASE I

# STRATA PLAN VR 2382

SHEET 26 OF 30 SHEETS

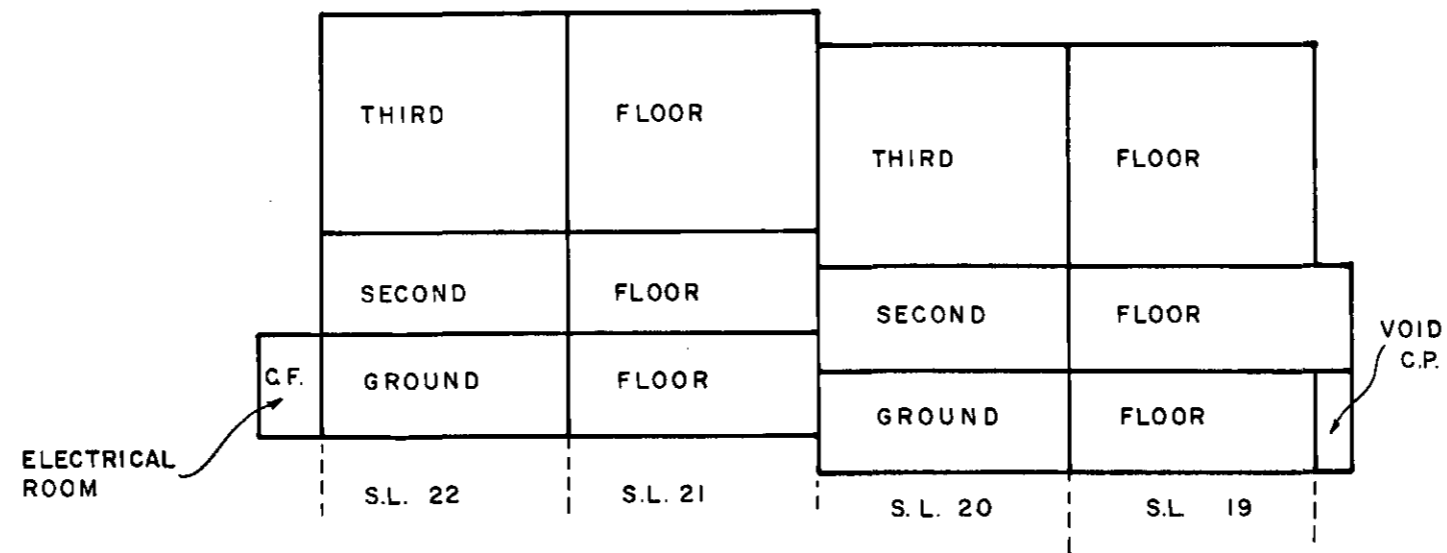
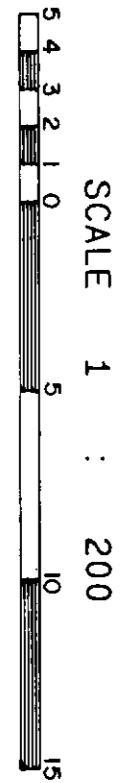

NOTE:  
 S.L. DENOTES STRATA LOT  
 C.P. DENOTES COMMON PROPERTY  
 L.C.P. DENOTES LIMITED COMMON PROPERTY  
 C.F. DENOTES COMMON FACILITY  
 PT. DENOTES COMMON PART  
 B. DENOTES BALCONY  
 BALCONIES ARE COMMON PROPERTY AND ARE NOT INCLUDED IN SQUARE METRE (M<sup>2</sup>) AREAS  
 ALL DISTANCES ARE IN METRES.

*BB*

*January 16,*

B.C.L.S.

1989

J88038

SP883588

# CROSS-SECTIONS PHASE I

# STRATA PLAN VR 2382

SHEET 27 OF 30 SHEETS

SCALE 1 : 200

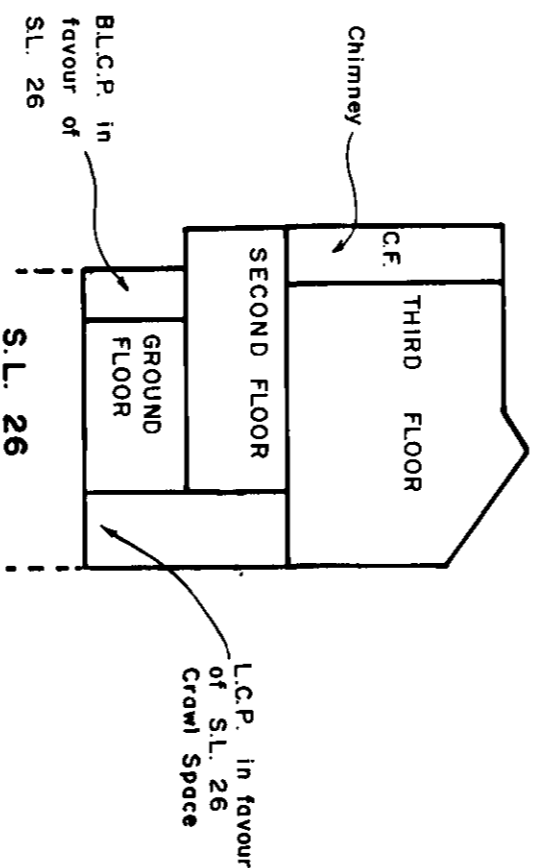

CROSS - SECTION 'K - K'  
BUILDING 6

NOTE:

- S.L. DENOTES STRATA LOT
- C.P. DENOTES COMMON PROPERTY
- L.C.P. DENOTES LIMITED COMMON PROPERTY
- C.F. DENOTES COMMON FACILITY
- PT. DENOTES PART
- B. DENOTES BALCONY

BALCONIES ARE COMMON PROPERTY AND ARE NOT INCLUDED IN SQUARE METRE (M<sup>2</sup>) AREAS  
ALL DISTANCES ARE IN METRES.

B.C.L.S.

January 16, 1989

J68036

SP88358B

# CROSS-SECTIONS PHASE I

# STRATA PLAN VR 238Z

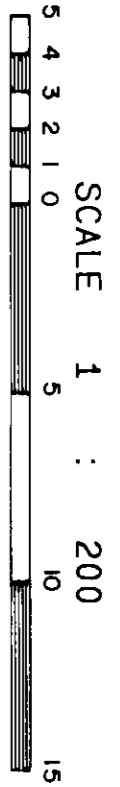

SHEET 28 OF 30 SHEETS

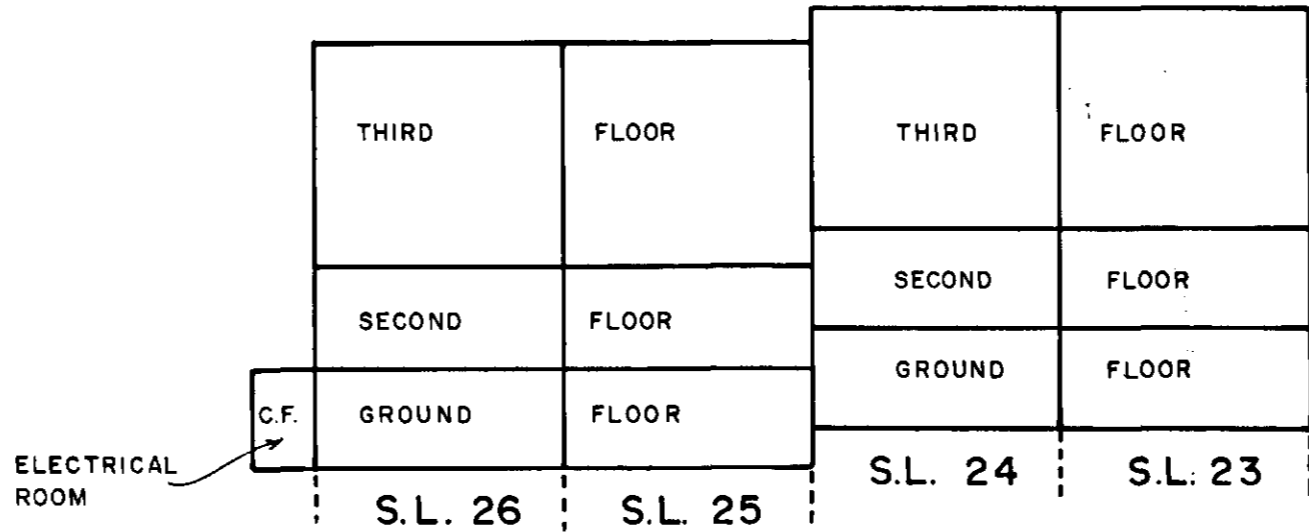

CROSS-SECTION 'L-L'  
BUILDING 6

NOTE:

- S.L. DENOTES STRATA LOT
- C.P. DENOTES COMMON PROPERTY
- L.C.P. DENOTES LIMITED COMMON PROPERTY
- C.F. DENOTES COMMON FACILITY
- PT. DENOTES PART
- B. DENOTES BALCONY

BALCONIES ARE COMMON PROPERTY AND ARE NOT INCLUDED IN SQUARE METRE (M<sup>2</sup>) AREAS  
ALL DISTANCES ARE IN METRES.

B.C.L.S.

*[Signature]*  
January 16, 1989

J88038

SP883588

PHASE I STRATA PLAN VR 2382

RECORD OF BY LAWS AND ORDERS , ETC.

FILING	NUMBER	DATE	DATE	NATURE AND PARTICULARS
	GC 34838	20/3/89		NOTIFICATION OF CHANGE OF BYLAWS

\*  
 Search ATOS2  
 Current Information. Doc. No. 76/75

~~Page~~ Sheet closed

*BB*  
 B.C.L.S.  
 January 16, 1989

Common Property Sheet Closed 21/10/95  
Search ALTOS2 or BC Online for  
Current Information BC Reg. 96/95

SHEET 30 OF 30 SHEETS

*Bob* PHASE I

STRATA PLAN VR 2382

LINDA J. OSHEA, Registrar  
Vancouver  
Minister of Land Title

DEALINGS AFFECTING THE COMMON PROPERTY

FILING		DOCUMENT	
NUMBER	DATE	DATE	NATURE AND PARTICULARS
K 242	5/1/82		COVENANT IN FAVOUR OF RESORT MUNICIPALITY OF WHISTLER, 5.215 L.T.A. PART THEREIN DESCRIBED; INTER ALIA
K 243	5/1/82		STATUTORY RIGHT OF WAY IN FAVOUR OF RESORT MUNICIPALITY OF WHISTLER AS TO AN UNDIVIDED 944/10000 SHARE IN LOT 11; INTER ALIA
K 10130	17/2/82		STATUTORY RIGHT OF WAY IN FAVOUR OF BRITISH COLUMBIA TELEPHONE COMPANY AS TO AN UNDIVIDED 944/10000 SHARE IN LOT 11; INTER ALIA
K 11110	23/2/82		STATUTORY RIGHT OF WAY IN FAVOUR OF BRITISH COLUMBIA HYDRO AND POWER AUTHORITY, AS TO AN UNDIVIDED 944/10000 SHARE IN LOT 11; INTER ALIA
K 17082	18/3/82		STATUTORY RIGHT OF WAY IN FAVOUR OF BRITISH COLUMBIA HYDRO AND POWER AUTHORITY, PART IN EXPLANATORY PLAN 16133; INTER ALIA
K 24211	21/4/82		STATUTORY RIGHT OF WAY IN FAVOUR OF RESORT MUNICIPALITY OF WHISTLER AS TO AN UNDIVIDED 944/10000 SHARE IN LOT 11; INTER ALIA

*BB*

B.C.L.S.

January 16, 1989

J88038

SP88358B



STRATA PLAN OF LOT 36, EXCEPT  
 PART IN PHASE 1, STRATA PLAN VR 2381  
 AND AN UNDIVIDED 224/10000 INTEREST  
 IN LOT 11, PLAN 19070, BLOCK F,  
 DISTRICT LOT 4749, PLAN 22122,  
 GROUP 1, N.W.D.

FIRST SHEET SHEET 1 OF 10 SHEETS  
**STRATA PLAN VR 2381**

DEPOSITED AND REGISTERED IN THE LAND  
 TITLE OFFICE AT VANCOUVER, B.C.,  
 THIS 2<sup>ND</sup> DAY OF OCTOBER, 1989.

PHASE II

SCALE 1 : 1250

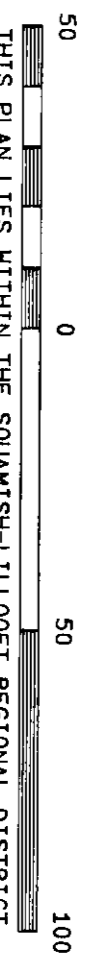

THIS PLAN LIES WITHIN THE SQUAMISH-LILLOET REGIONAL DISTRICT  
 RESORT MUNICIPALITY OF WHISTLER  
 THE ADDRESS FOR SERVICE OF DOCUMENTS  
 ON THE STRATA CORPORATION IS:-  
 THE OWNERS STRATA PLAN VR 2381

CHRIST - WILLIAMS  
 880-1090 W. GEORGIA STREET  
 VANCOUVER, B.C.

CIVIC ADDRESS :  
 2240 GONDOLA WAY

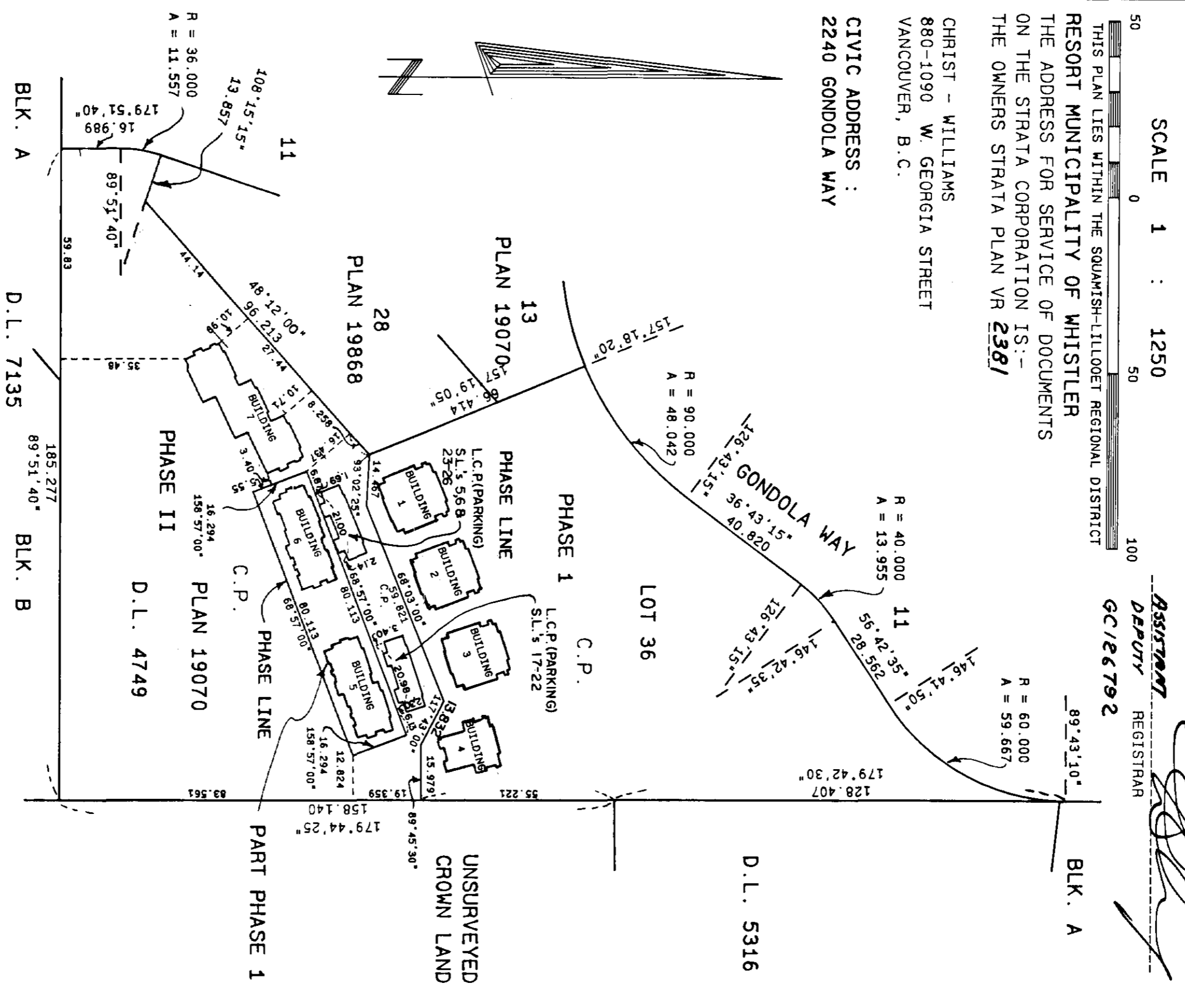

NOTE:  
 C.P. DENOTES COMMON PROPERTY  
 L.C.P. DENOTES LIMITED COMMON PROPERTY  
 S.L. DENOTES STRATA LOT  
 ALL DISTANCES ARE IN METRES

I, BRIAN O. BROWN, OF WHISTLER, B.C.,  
 A BRITISH COLUMBIA LAND SURVEYOR,  
 HEREBY CERTIFY THAT THE BUILDING  
 ERCTED ON THE PARCEL DESCRIBED  
 ABOVE IS WHOLLY WITHIN THE EXTERNAL  
 BOUNDARIES OF THAT PARCEL.  
 DATED AT WHISTLER, B.C. THIS 6th DAY  
 OF JULY, 1989.

Robert B. Brown & Associates  
 Professional Land Surveyors  
 P.O. Box 13, Whistler, B.C.  
 VON 1B0 932 - 5426

*Brian O. Brown*

B.C.L.S.

J88038

SP890968



# CONDOMINIUM ACT PHASE II

# STRATA PLAN VR 2381

SECOND SHEET SHEET 2 OF 10 SHEETS

LOT NO.	SHEET NO.	FORM 1 SECTION 3(1)(f)		FORM 2 SECTION 3(1)(g)		FORM 3 SECTION 3(1)(h)	
		SCHEDULE OF UNIT ENTITLEMENT	UNIT ENTITLEMENT	SCHEDULE OF INTEREST UPON DESTRUCTION	INTEREST UPON DESTRUCTION	SCHEDULE OF VOTING RIGHTS	NUMBER OF VOTES
27	5,6,7		11310		173		
28	5,6,7		10950		173		
29	5,6,7		11030		168		
30	5,6,7		11020		173		
31	5,6,7		10980		168		
32	5,6,7		11260		173		
AGGREGATE PHASE II			66550		1028		
AGGREGATE PHASE I			212004		3452		
TOTAL AGGREGATE			278554		4480		

ACCEPTED AS TO FORMS 1, 2 & 3  
This 27th Day of September 1989.

*Terrie Le-Grady*  
SUPERINTENDENT OF REAL ESTATE

Robert B. Brown & Associates  
Professional Land Surveyors  
P.O. Box 13, Whistler, B.C.  
V0N 1B0 932 - 5426

*RB*  
B.C.L.S.  
July 6, 1989.

J88038

SP890968

CONDOMINIUM ACT  
PHASE II

STRATA PLAN VR 2381

STATUTORY DECLARATION

I, THE UNDERSIGNED, DO SOLEMNLY DECLARE THAT: -  
(1) I, THE UNDERSIGNED, AM THE DULY AUTHORIZED AGENT OF THE OWNER DEVELOPER  
(2) THE STRATA PLAN IS ENTIRELY FOR RESIDENTIAL USE  
I MAKE THIS SOLEMN DECLARATION CONSCIENTIOUSLY BELIEVING IT TO BE TRUE, AND  
KNOWING THAT IT IS OF THE SAME FORCE AND EFFECT AS IF MADE UNDER OATH.

DECLARED BEFORE ME AT - Vancouver  
IN THE PROVINCE OF BRITISH COLUMBIA  
THIS 17<sup>th</sup> DAY OF July, 1989.

William Alan Janyk  
William Alan Janyk

COMMISSIONER FOR TAKING AFFIDAVITS WITHIN THE  
PROVINCE OF BRITISH COLUMBIA  
M.A. Chan

SIGNATURES

MORTGAGEES

OWNER

William Alan Janyk  
WILLIAM ALAN JANYK

AETNA TRUST COMPANY

WITNESS M.A. Chan

AUTHORIZED SIGNATORY

ADDRESS 880-1030 W. Georgia St.  
Van. B.C.

AUTHORIZED SIGNATORY

OCCUPATION Solicitor

RICHMOND SAVINGS CREDIT UNION

Ronald George Albertin  
RONALD GEORGE ALBERTIN

AUTHORIZED SIGNATORY

WITNESS M.A. Chan

AUTHORIZED SIGNATORY

ADDRESS 880-1030 W. Georgia St.  
Van. B.C.

AUTHORIZED SIGNATORY

OCCUPATION Solicitor

C.H.N. INVESTMENTS LTD.

[Signature]  
AUTHORIZED SIGNATORY

AUTHORIZED SIGNATORY

AUTHORIZED SIGNATORY

Brian O. Brown  
B.C.L.S.

APPROVED AS PHASE 2 OF A 2 PHASE  
STRATA PLAN UNDER THE "CONDOMINIUM ACT"  
THIS 12 DAY OF Sept, 1989.

[Signature]  
APPROVING OFFICER-RESORT MUNICIPALITY OF WHISTLER

[Signature]  
B.C.L.S.

Robert B. Brown & Associates  
Professional Land Surveyors  
P.O. Box 13, Whistler, B.C.  
V0N 1B0 932 - 5426

July 6, 1989.

J88038

SP890968

STRATA PLAN VR 2381

SHEET 4 OF 10 SHEETS

PHASE II

SHARES OF UNDIVIDED 944/10000  
INTEREST IN LOT 11

S.L. NO.	AREA	SHARE OF UNDIVIDED 944/10000 INTEREST IN LOT 11
27	113.1 m <sup>2</sup>	38/10000
28	109.5 m <sup>2</sup>	37/10000
29	110.3 m <sup>2</sup>	37/10000
30	110.2 m <sup>2</sup>	37/10000
31	109.8 m <sup>2</sup>	37/10000
32	112.6 m <sup>2</sup>	38/10000
AGGREGATE PHASE II	665.5 m <sup>2</sup>	224/10000
AGGREGATE PHASE I	2120.0 m <sup>2</sup>	720/10000
AGGREGATE	2785.5 m <sup>2</sup>	944/10000

  
 -----  
 B.C.L.S.  
 July 6, 1989.

J88038

SP890968

PLAN OF STRATA LOTS 27-32

STRATA PLAN VR 2381

SHEET 5 OF 10 SHEETS



PHASE II

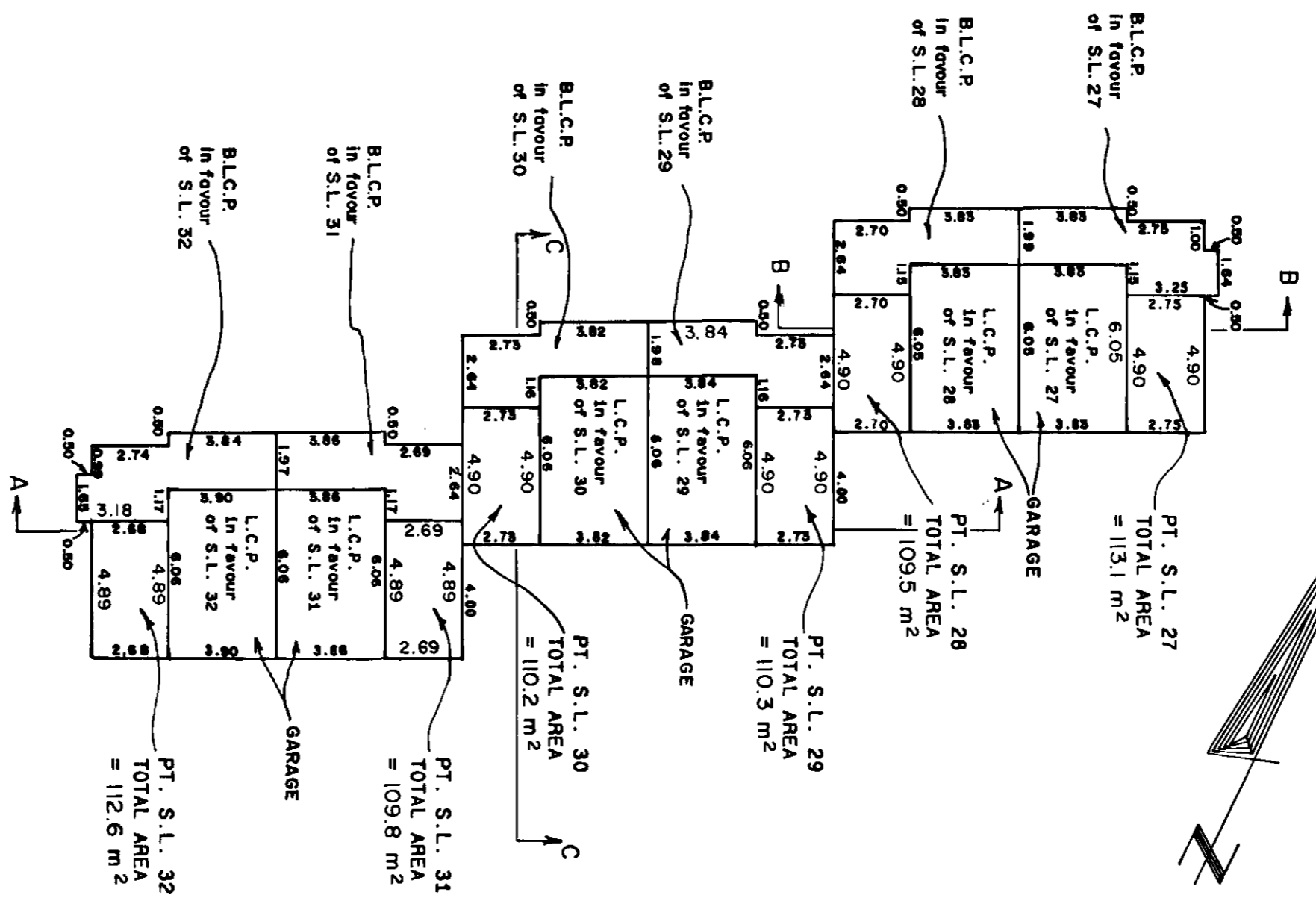

NOTE:

- S.L. DENOTES STRATA LOT
- C.P. DENOTES COMMON PROPERTY
- L.C.P. DENOTES LIMITED COMMON PROPERTY
- C.F. DENOTES COMMON FACILITY
- PT. DENOTES PART
- B. DENOTES BALCONY

BALCONIES ARE COMMON PROPERTY AND ARE NOT INCLUDED IN SQUARE METRE (M<sup>2</sup>) AREAS  
ALL DISTANCES ARE IN METRES.

PLAN OF GROUND FLOOR BUILDING 7

*[Signature]*  
 July 6, 1989  
 B.C.L.S.

J88038

SP89096B

# PLAN OF STRATA LOTS 27-32

# STRATA PLAN VR 2381

SHEET 6 OF 10 SHEETS

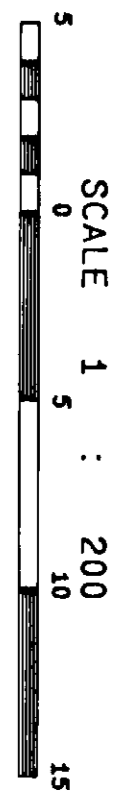

PHASE II

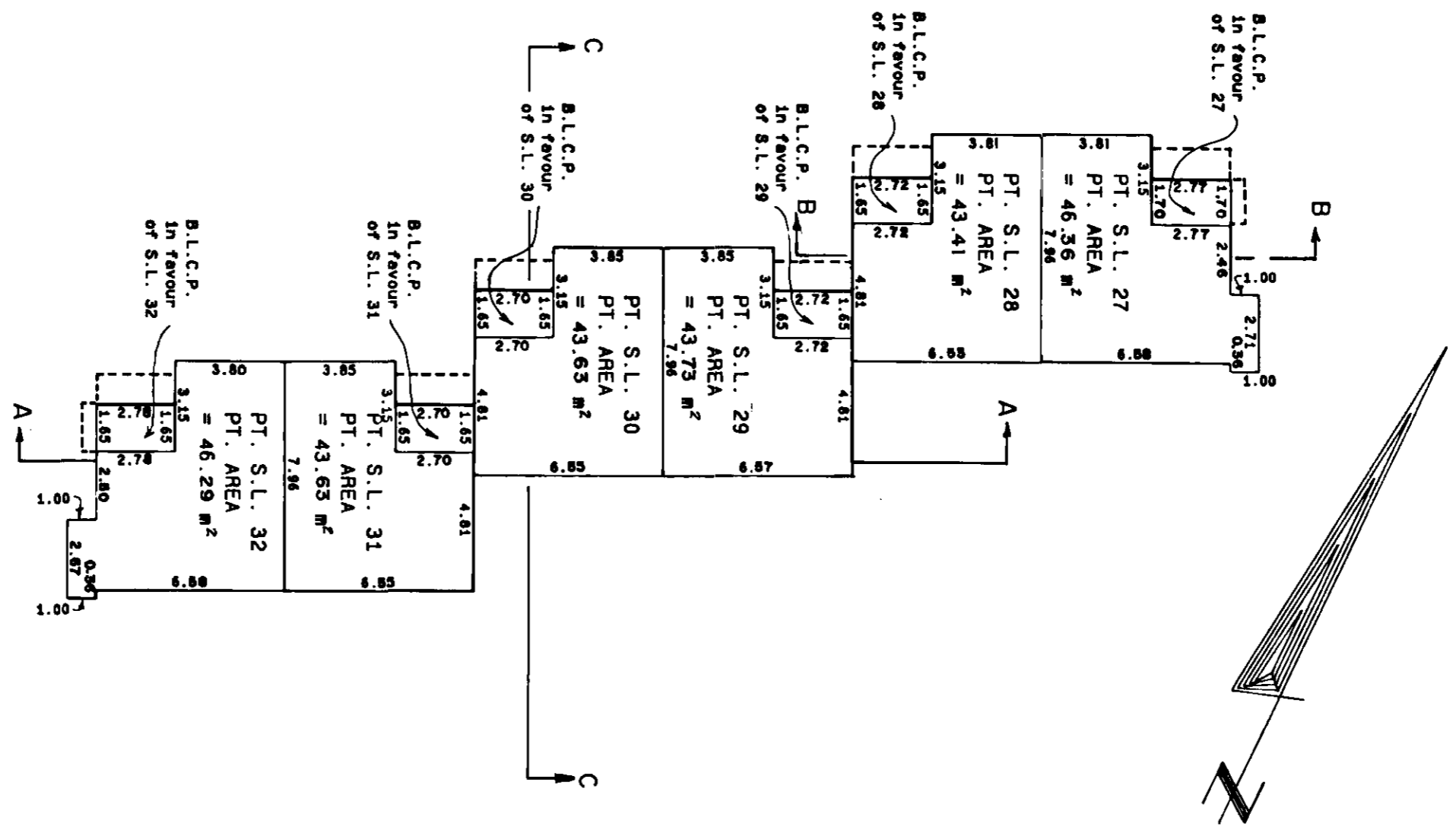

PLAN OF SECOND FLOOR BUILDING 7

NOTE:

- S.L. DENOTES STRATA LOT
- C.P. DENOTES COMMON PROPERTY
- L.C.P. DENOTES LIMITED COMMON PROPERTY
- C.F. DENOTES COMMON FACILITY
- PT. DENOTES COMMON PART
- B. DENOTES BALCONY

BALCONIES ARE COMMON PROPERTY AND ARE NOT INCLUDED IN SQUARE METRE (M<sup>2</sup>) AREAS  
ALL DISTANCES ARE IN METRES.

*BB*  
B.C.L.S.

*July 6,*  
1989

J 88038

SP 89096 B

# PLAN OF STRATA LOTS 27-32

# STRATA PLAN VR 2381

SHEET 7 OF 10 SHEETS

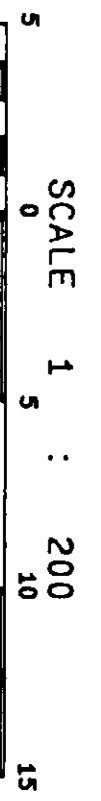

PHASE II

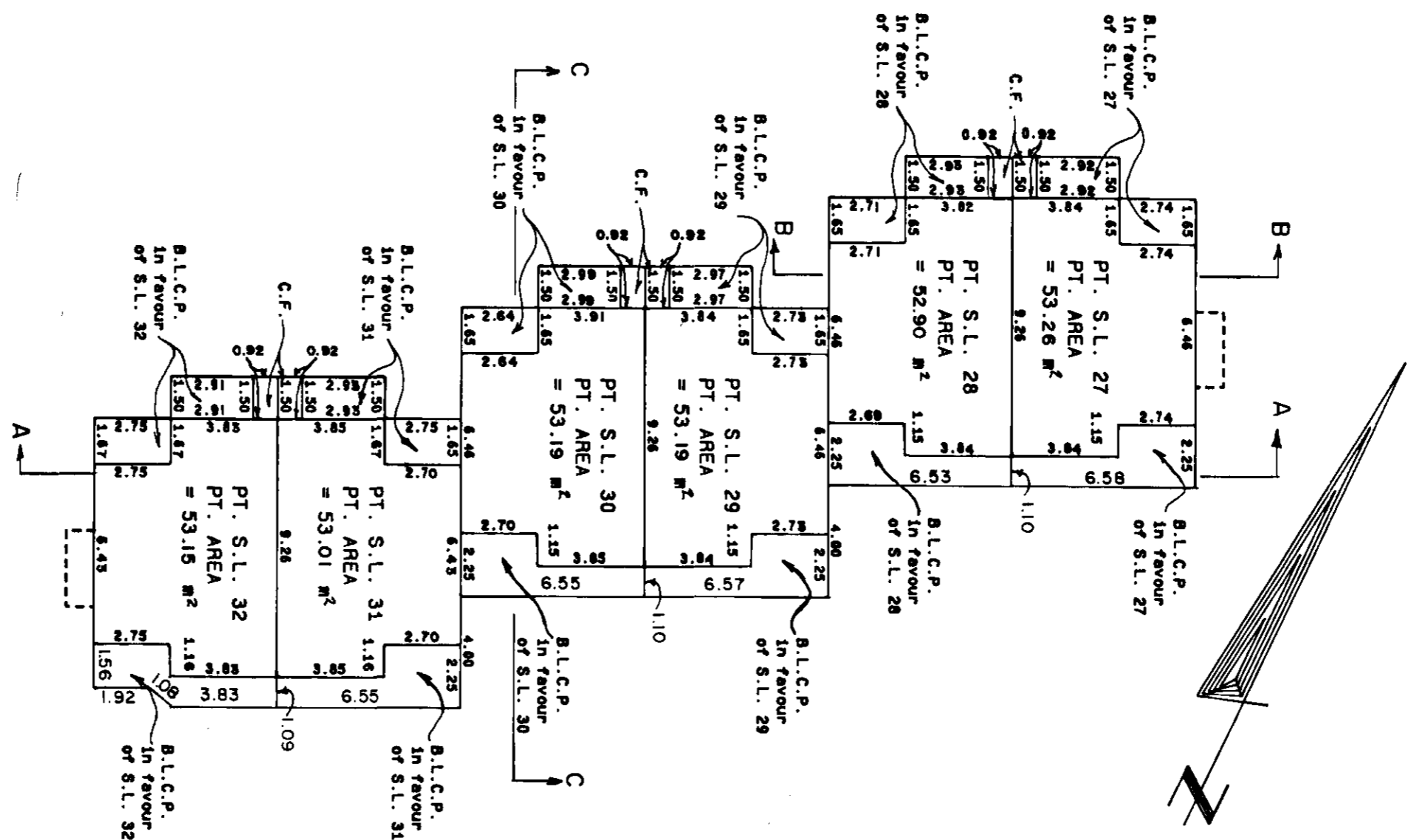

### PLAN OF THIRD FLOOR BUILDING 7

NOTE:

- S.L. DENOTES STRATA LOT
- C.P. DENOTES COMMON PROPERTY
- L.C.P. DENOTES LIMITED COMMON PROPERTY
- C.F. DENOTES COMMON FACILITY
- PT. DENOTES COMMON PART
- B. DENOTES BALCONY

BALCONIES ARE COMMON PROPERTY AND ARE NOT INCLUDED IN SQUARE METRE (M<sup>2</sup>) AREAS  
ALL DISTANCES ARE IN METRES.

*BB*  
 \_\_\_\_\_  
 July 6, 1989  
 B.C.L.S.

J 88038

SP 89096 B

# CROSS-SECTIONS

SHEET 8 OF 10 SHEETS

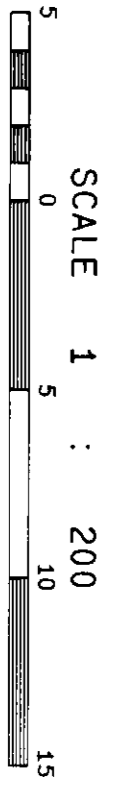

## STRATA PLAN VR 2381

### BUILDING 7 CROSS-SECTION 'A-A'

#### PHASE II

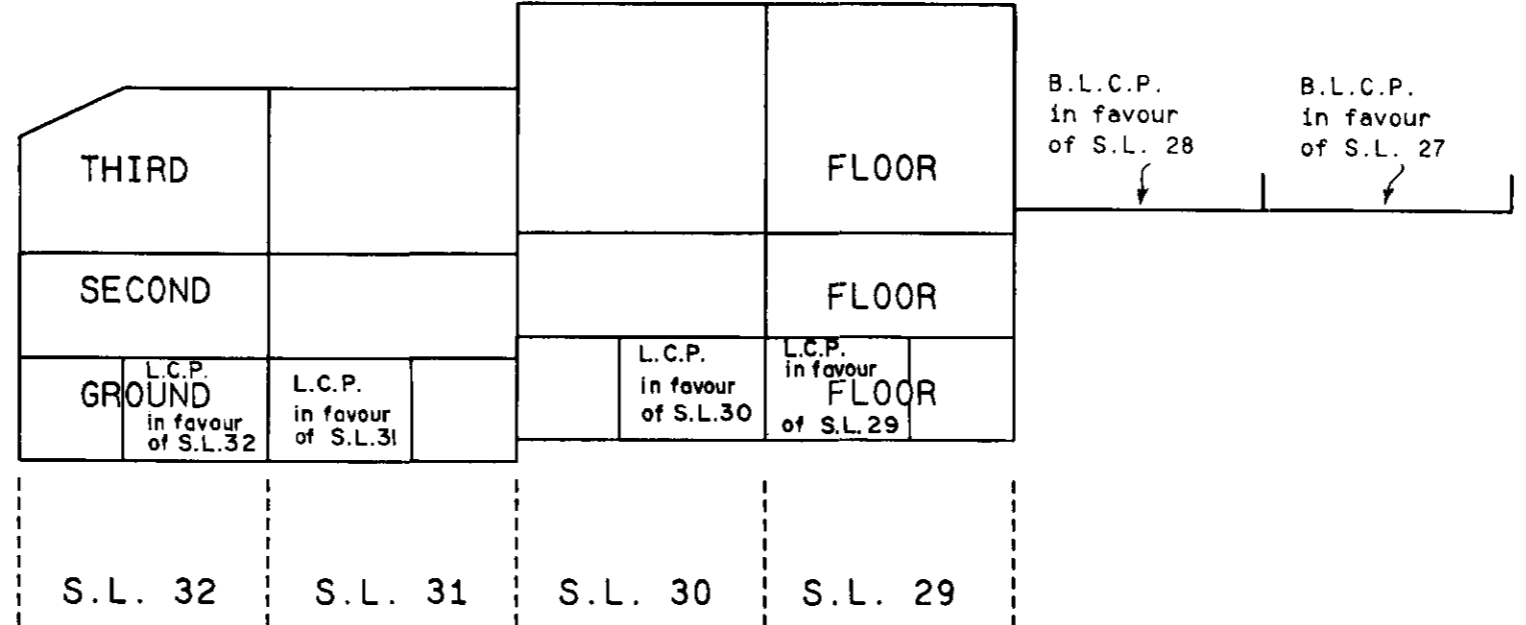

NOTE:  
 S.L. DENOTES STRATA LOT  
 C.P. DENOTES COMMON PROPERTY  
 L.C.P. DENOTES LIMITED COMMON PROPERTY  
 C.F. DENOTES COMMON FACILITY  
 PT. DENOTES PART  
 B. DENOTES BALCONY  
 BALCONIES ARE COMMON PROPERTY AND ARE NOT INCLUDED IN SQUARE METRE (m<sup>2</sup>) AREAS  
 ALL DISTANCES ARE IN METRES.

*BB*  
 B.C.L.S.  
 July 6, 1989.

J88038

SP890968

# CROSS-SECTIONS

SCALE 1 : 200



SHEET 9 OF 10 SHEETS

# STRATA PLAN VR 2381

## BUILDING 7

### CROSS-SECTIONS 'B-B' AND 'C-C'

#### PHASE II

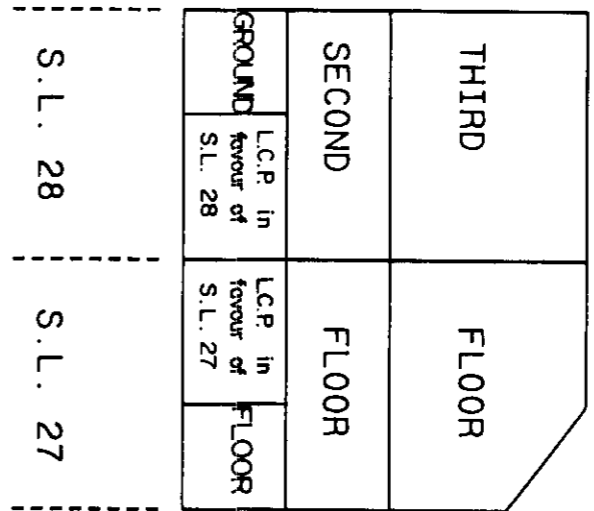

CROSS-SECTION 'B-B'

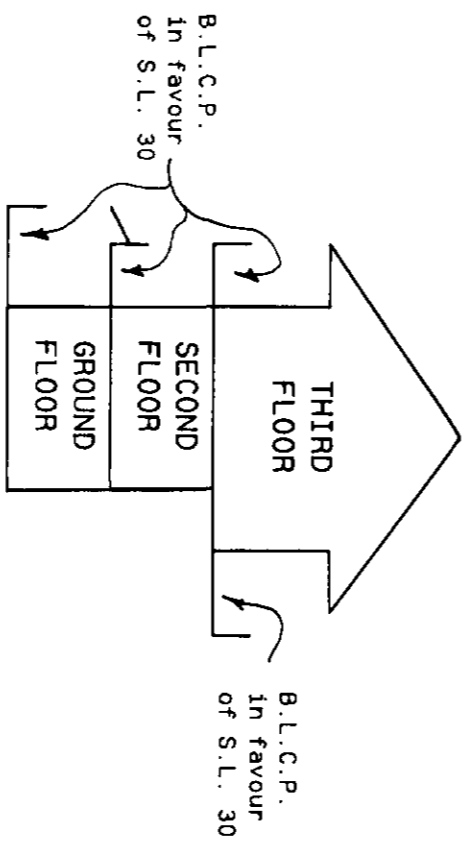

CROSS-SECTION 'C-C'

- NOTE:
- S.L. DENOTES STRATA LOT
  - C.P. DENOTES COMMON PROPERTY
  - L.C.P. DENOTES LIMITED COMMON PROPERTY
  - C.F. DENOTES COMMON FACILITY
  - PT. DENOTES PART
  - B. DENOTES BALCONY
- BALCONIES ARE COMMON PROPERTY AND ARE NOT INCLUDED IN SQUARE METRE (m<sup>2</sup>) AREAS  
ALL DISTANCES ARE IN METRES.

*BB*  
 \_\_\_\_\_ B.C.L.S.  
 July 6, \_\_\_\_\_ 1989.

J88038

SP89096B



# PLAN OF L.C.P. FOR STRATA LOTS 5, 6 AND 17-26

SCALE 1 : 200

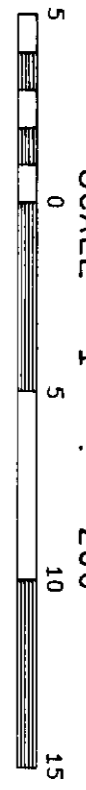

# STRATA PLAN VR 2381

SHEET 10 OF 10 SHEETS

## PHASE II PLAN OF PARKING

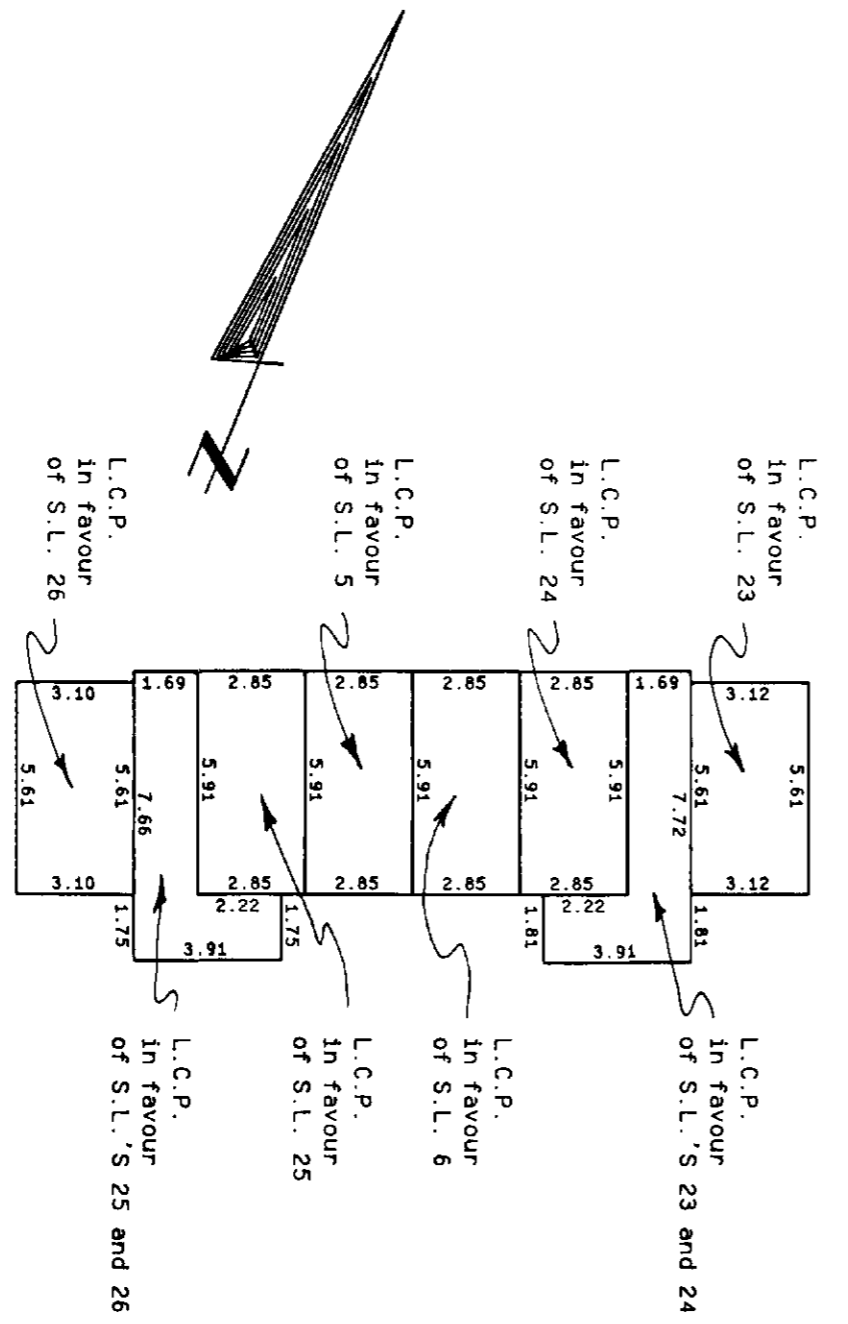
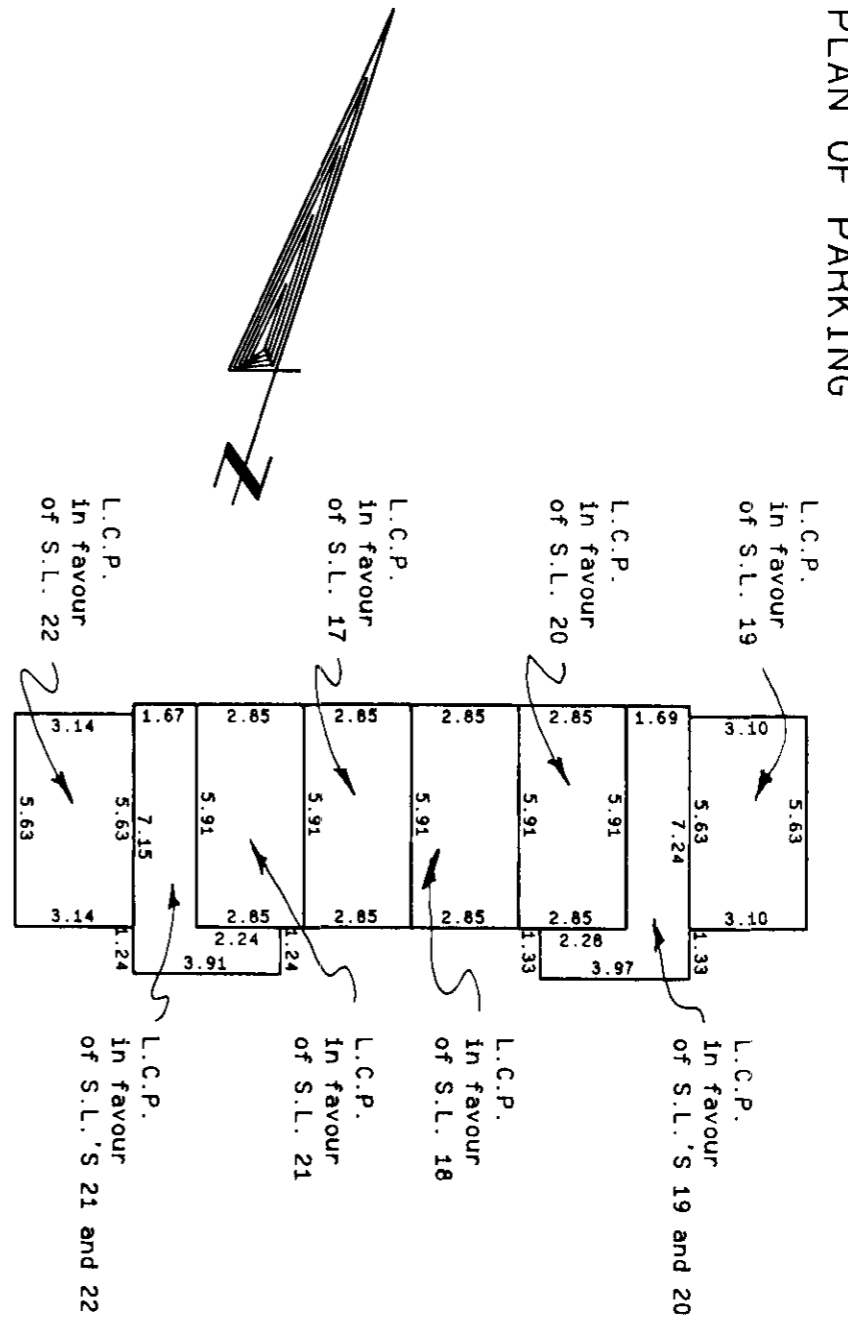

NOTE:  
L.C.P. DENOTES LIMITED COMMON PROPERTY  
S.L. DENOTES STRATA LOT

*BB*  
B.C.L.S.  
July 6, 1989.

J88038

SP89096B