

PROPERTY OF THE WHISTLER
REAL ESTATE CO. LTD.

FIRST SHEET SHEET 1 OF 16 SHEETS

STRATA PLAN ON LOT 6, D.L. ~~1755~~ 1755
PLAN LMP 171, GROUP 1, N.W.D.

STRATA PLAN LMS 1211

B.C.G.S. 92J.016

DEPOSITED AND REGISTERED IN THE LAND
TITLE OFFICE AT NEW WESTMINSTER, B.C.
THIS 21 DAY OF JANUARY, 1993

SCALE 1 : 750

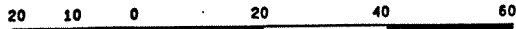

THIS PLAN LIES WITHIN THE SQUAMISH-LILLOOET REGIONAL DISTRICT

RESORT MUNICIPALITY OF WHISTLER
THE ADDRESS FOR SERVICE OF DOCUMENTS
ON THE STRATA CORPORATION IS:-
THE OWNERS STRATA PLAN LMS -----

REGISTRAR

C/O P.O. BOX 49130,
#2900 - 595 BURRARD STREET,
VANCOUVER, B.C. V7X 1J5

CIVIC ADDRESS: 3554 FALCON CRESCENT
WHISTLER, B.C.

KEY PLAN

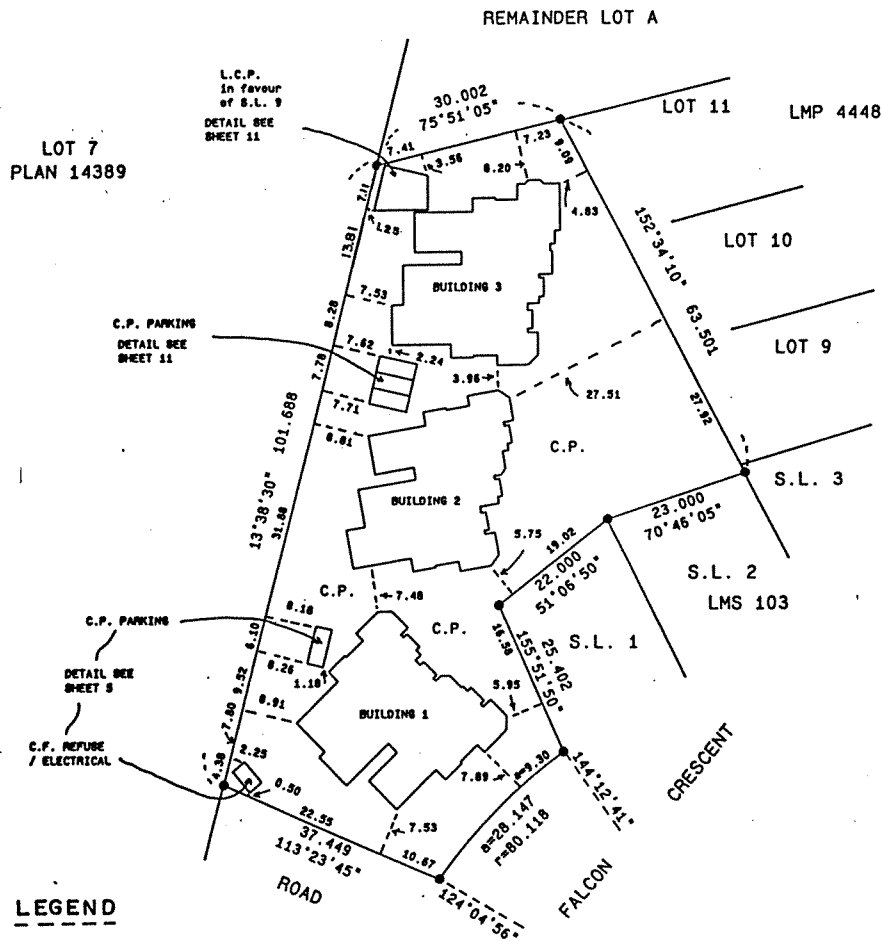

LEGEND

- DENOTES STANDARD IRON POST FOUND
 - S.L. DENOTES STRATA LOT
 - C.P. DENOTES COMMON PROPERTY
 - C.F. DENOTES COMMON FACILITY
 - L.C.P. DENOTES LIMITED COMMON PROPERTY
- ALL DISTANCES ARE IN METRES.

I, BRIAN O. BROWN, OF WHISTLER, B.C., A
BRITISH COLUMBIA LAND SURVEYOR, HEREBY
CERTIFY THAT THE BUILDINGS ERECTED ON THE
PARCEL DESCRIBED ABOVE ARE WHOLLY WITHIN
THE EXTERNAL BOUNDARIES OF THAT PARCEL.
DATED AT WHISTLER, B.C. THIS 10th
DAY OF DECEMBER, 1993.

R. B. Brown Land Surveying Ltd.
Professional Land Surveyors
P.O. Box 13, Whistler, B.C.
VON 1B0 932 - 5426

Brian O. Brown B.C.L.S.

PROPERTY OF THE WHISTLER
REAL ESTATE CO. LTD.

CONDOMINIUM ACT

STRATA PLAN LMS _____

STATUTORY DECLARATION

I, THE UNDERSIGNED, DO SOLEMNLY DECLARE THAT:-
(1) I, THE UNDERSIGNED, AM THE DULY AUTHORIZED AGENT OF THE OWNER DEVELOPER
(2) THE STRATA PLAN IS ENTIRELY FOR RESIDENTIAL USE
I MAKE THIS SOLEMN DECLARATION CONSCIENTIOUSLY BELIEVING IT TO BE TRUE, AND
KNOWING THAT IT IS OF THE SAME FORCE AND EFFECT AS IF MADE UNDER OATH.

DECLARED BEFORE ME AT - BURNABY
IN THE PROVINCE OF BRITISH COLUMBIA
THIS 23RD DAY OF DECEMBER, 1993.

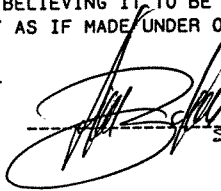

STEVE BALIC

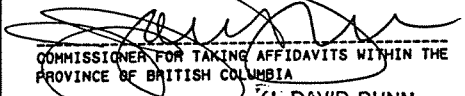
COMMISSIONER FOR TAKING AFFIDAVITS WITHIN THE
PROVINCE OF BRITISH COLUMBIA
J. DAVID DUNN

MORTGAGEE

SIGNATURES

ROYAL BANK OF CANADA

AUTHORIZED SIGNATORY PETER FREDERIC JOHNSTON
Manager, Lending

AUTHORIZED SIGNATORY Chester Lee Bajer
Assistant Manager, Lending

OWNER

BLUEBERRY TEN ENTERPRISES LTD.
(INC. No. 435657)

AUTHORIZED SIGNATORY STEVE BALIC



WITNESS AS TO BOTH SIGNATURES

JUDY MILLER
ADDRESS 1025 West Georgia St.
Vancouver, B.C. V6E 3N9

Secretary
OCCUPATION

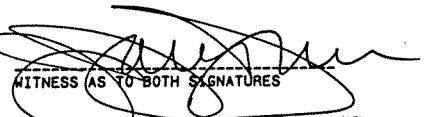
AUTHORIZED SIGNATORY

WITNESS AS TO BOTH SIGNATURES
J. DAVID DUNN
BARRISTER & SOLICITOR
ADDRESS 29th FLOOR - 565 CURRIARD STREET
VANCOUVER, B.C. V7X 1J5
(604-681)

OCCUPATION

I, BRIAN O. BROWN OF THE MUNICIPALITY
OF WHISTLER, BRITISH COLUMBIA LAND
SURVEYOR, HEREBY CERTIFY THAT THE
BUILDINGS SHOWN IN THIS STRATA PLAN
HAVE NOT, AS OF THE 10th DAY OF
DECEMBER, 1993, BEEN PREVIOUSLY
OCCUPIED. DATED AT WHISTLER, BRITISH
COLUMBIA THIS 10th DAY OF DECEMBER,
1993.

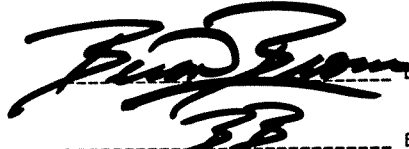

B.C.L.S.

B.C.L.S.
December 10, 1993.

R. B. Brown Land Surveying Ltd.
Professional Land Surveyors
P.O. Box 13, Whistler, B.C.
V0N 1B0 932 - 5426

PLAN OF S.L.'s 1-3 AND
COMMON PROPERTY

SHEET 4 OF 16 SHEETS

STRATA PLAN LMS

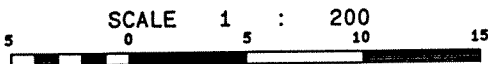

BUILDING 1
BASEMENT LEVEL

PROPERTY OF THE WHISTLER
REAL ESTATE CO. LTD.

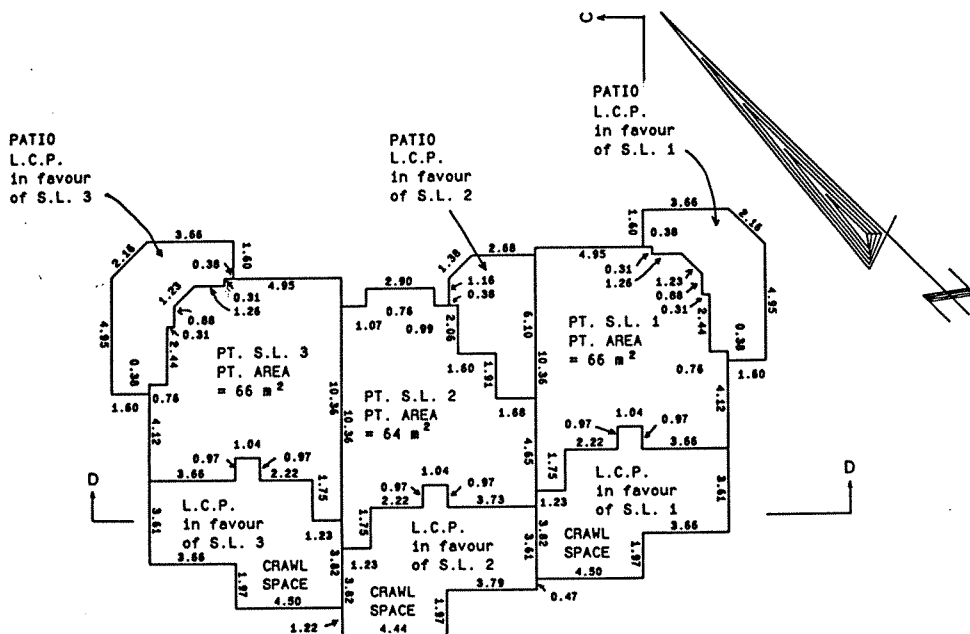

NOTE:
S.L. DENOTES STRATA LOT
C.P. DENOTES COMMON PROPERTY
L.C.P. DENOTES LIMITED COMMON PROPERTY
C.F. DENOTES COMMON FACILITY
PT. DENOTES PART
B. DENOTES BALCONY
BALCONIES ARE COMMON PROPERTY AND ARE
NOT INCLUDED IN SQUARE METRE (m²) AREAS
ALL DISTANCES ARE IN METRES.

JB
B.C.L.S.
December 10, 1993.

PLAN OF S.L.'s 1-3 AND
COMMON PROPERTY

STRATA PLAN LMS

SHEET 5 OF 16 SHEETS

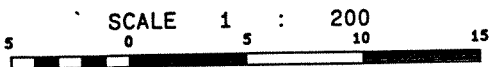

BUILDING 1
MAIN FLOOR

PROPERTY OF THE WHISTLER
REAL ESTATE CO. LTD.

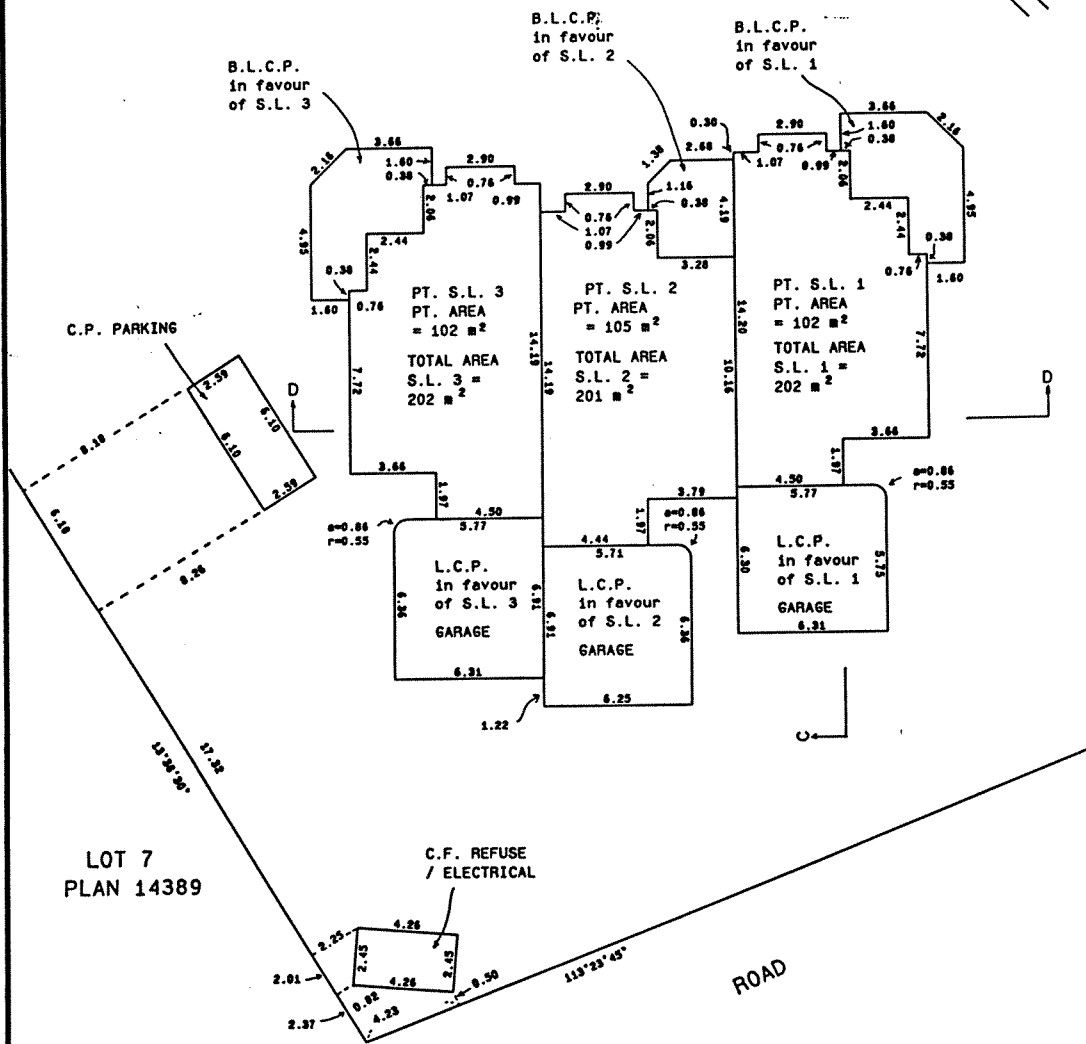

NOTE:
S.L. DENOTES STRATA LOT
C.P. DENOTES COMMON PROPERTY
L.C.P. DENOTES LIMITED COMMON PROPERTY
C.F. DENOTES COMMON FACILITY
PT. DENOTES PART
B. DENOTES BALCONY
BALCONIES ARE COMMON PROPERTY AND ARE NOT INCLUDED IN SQUARE METRE (m²) AREAS
ALL DISTANCES ARE IN METRES.

BB
December 10, 1993. B.C.L.S.

PLAN OF S.L.'s 1-3 AND
COMMON PROPERTY

SHEET 6 OF 16 SHEETS

STRATA PLAN LMS

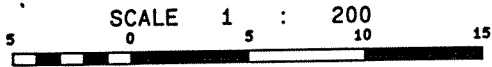

BUILDING 1
SECOND FLOOR

PROPERTY OF THE WHISTLER
REAL ESTATE CO. LTD.

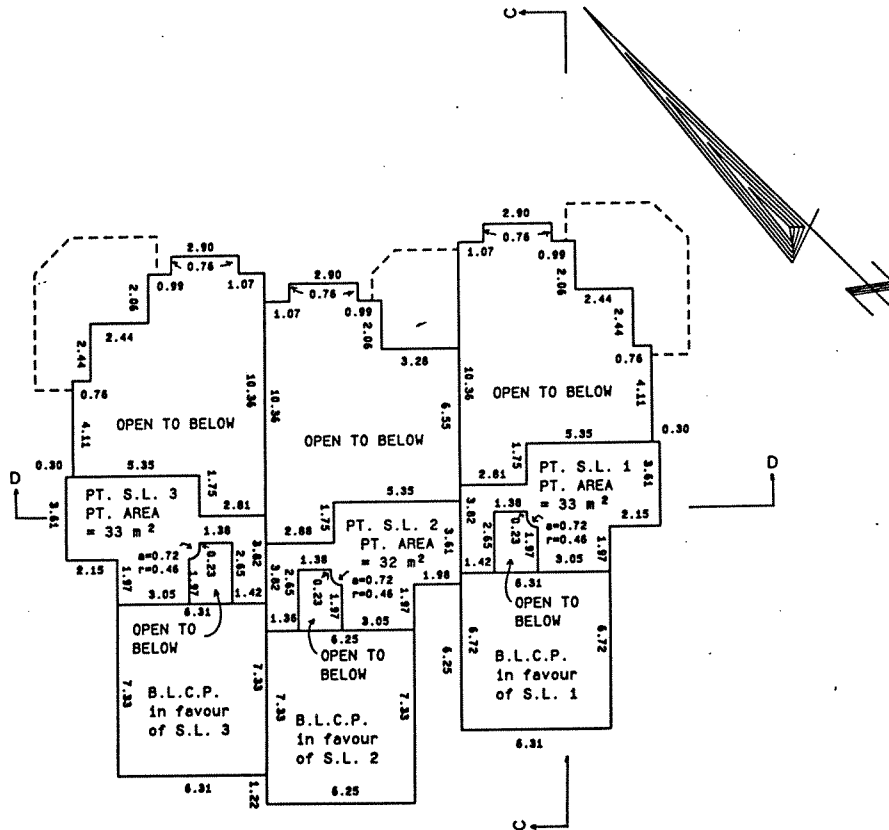

NOTE:
S.L. DENOTES STRATA LOT
C.P. DENOTES COMMON PROPERTY
L.C.P. DENOTES LIMITED COMMON PROPERTY
C.F. DENOTES COMMON FACILITY
PT. DENOTES PART
B. DENOTES BALCONY
BALCONIES ARE COMMON PROPERTY AND ARE NOT INCLUDED IN SQUARE METRE (m²) AREAS
ALL DISTANCES ARE IN METRES.

FB
B.C.L.S.
December 10, 1993.

PLAN OF S.L.'s 4-6 AND
COMMON PROPERTY

SHEET 7 OF 16 SHEETS

STRATA PLAN LMS

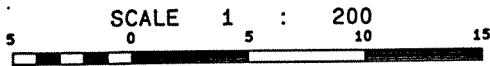

BUILDING 2
BASEMENT LEVEL

PROPERTY OF THE WHISTLER
REAL ESTATE CO. LTD.

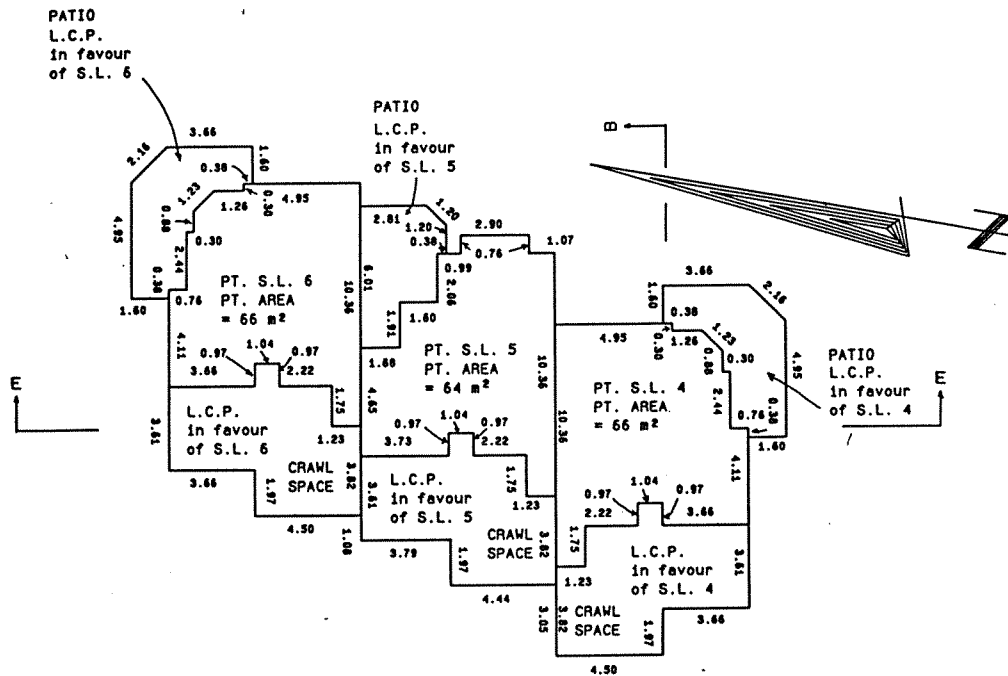

NOTE:
S.L. DENOTES STRATA LOT
C.P. DENOTES COMMON PROPERTY
L.C.P. DENOTES LIMITED COMMON PROPERTY
C.F. DENOTES COMMON FACILITY
PT. DENOTES PART
B. DENOTES BALCONY
BALCONIES ARE COMMON PROPERTY AND ARE NOT INCLUDED IN SQUARE METRE (m²) AREAS
ALL DISTANCES ARE IN METRES.

[Signature]
B.C.L.S.
December 10, 1993.

PLAN OF S.L.'s 4-6 AND
COMMON PROPERTY

STRATA PLAN LMS

SHEET 8 OF 16 SHEETS

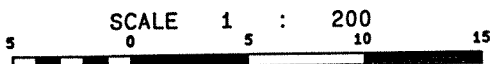

BUILDING 2
MAIN FLOOR

PROPERTY OF THE WHISTLER
REAL ESTATE CO. LTD.

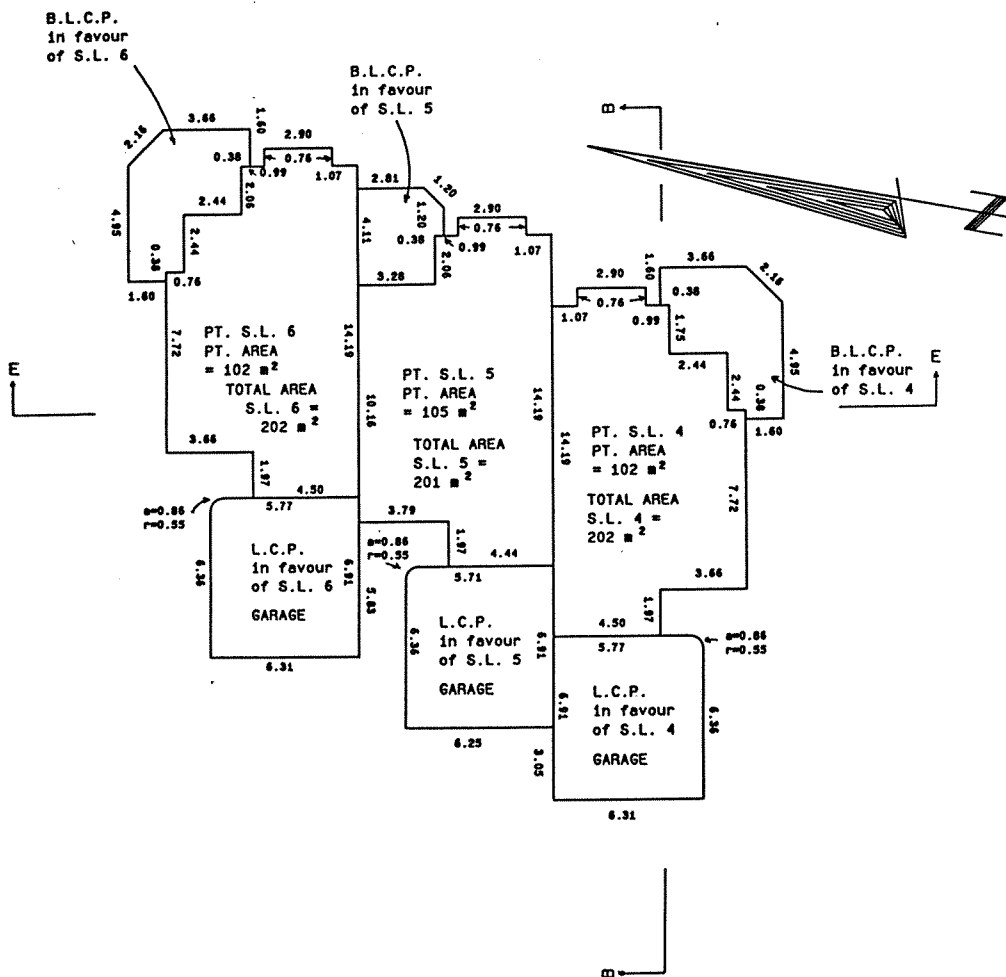

NOTE:
S.L. DENOTES STRATA LOT
C.P. DENOTES COMMON PROPERTY
L.C.P. DENOTES LIMITED COMMON PROPERTY
C.F. DENOTES COMMON FACILITY
PT. DENOTES PART
B. DENOTES BALCONY
BALCONIES ARE COMMON PROPERTY AND ARE NOT INCLUDED IN SQUARE METRE (m²) AREAS
ALL DISTANCES ARE IN METRES.

BB
December 10, 1993. B.C.L.S.

PLAN OF S.L.'s 4-6 AND
COMMON PROPERTY

STRATA PLAN LMS

SHEET 9 OF 16 SHEETS

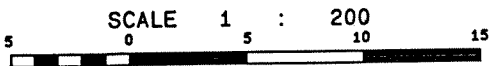

BUILDING 2
SECOND FLOOR

PROPERTY OF THE WHISTLER
REAL ESTATE CO. LTD.

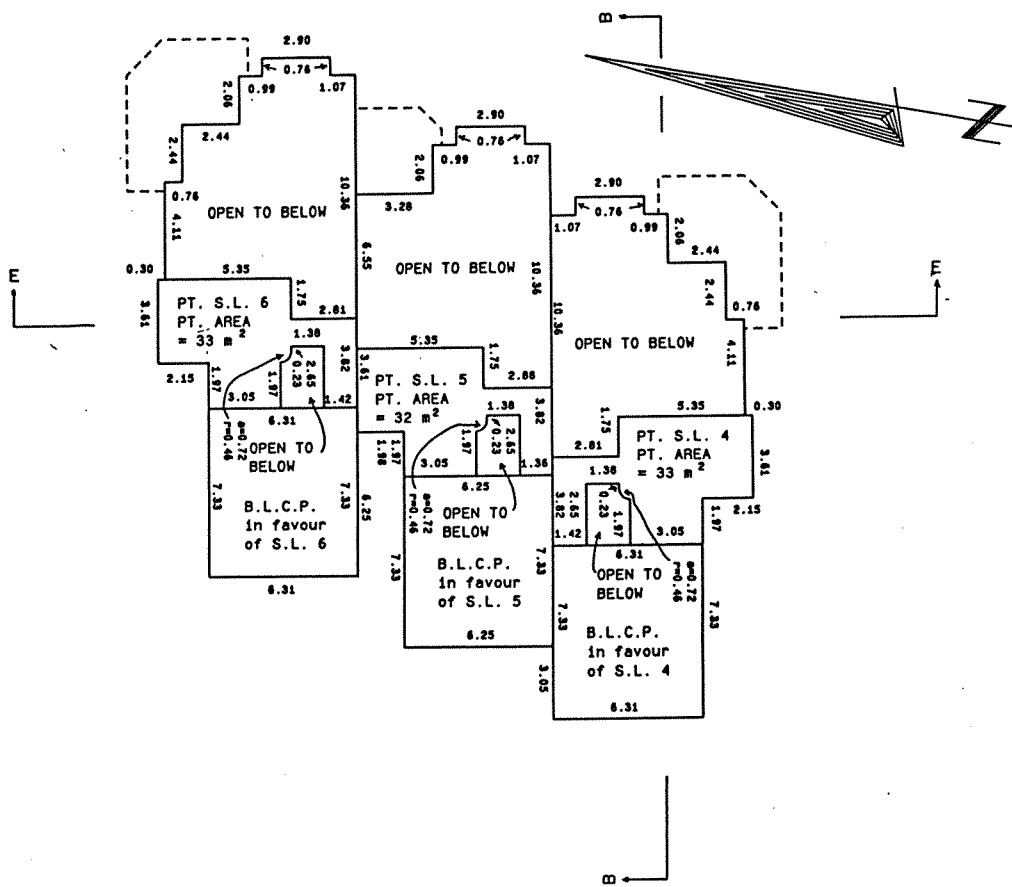

NOTE:
 S.L. DENOTES STRATA LOT
 C.P. DENOTES COMMON PROPERTY
 L.C.P. DENOTES LIMITED COMMON PROPERTY
 C.F. DENOTES COMMON FACILITY
 PT. DENOTES PART
 B. DENOTES BALCONY
 BALCONIES ARE COMMON PROPERTY AND ARE
 NOT INCLUDED IN SQUARE METRE (m²) AREAS
 ALL DISTANCES ARE IN METRES.

[Signature]
 B.C.L.S.
 December 10, 1993.

PLAN OF S.L.'s 7-9 AND
COMMON PROPERTY

STRATA PLAN LMS

SHEET 10 OF 16 SHEETS

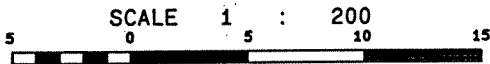

BUILDING 3
BASEMENT LEVEL

PROPERTY OF THE WHISTLER
REAL ESTATE CO. LTD.

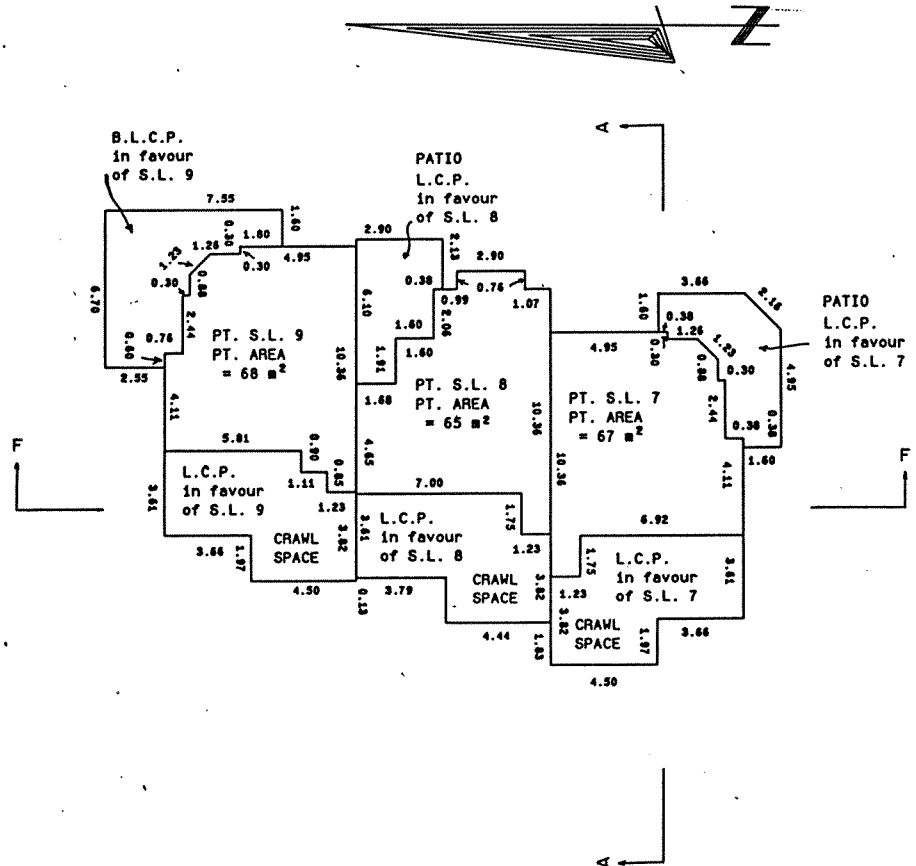

NOTE:
 S.L. DENOTES STRATA LOT
 C.P. DENOTES COMMON PROPERTY
 L.C.P. DENOTES LIMITED COMMON PROPERTY
 C.F. DENOTES COMMON FACILITY
 PT. DENOTES PART
 B. DENOTES BALCONY
 BALCONIES ARE COMMON PROPERTY AND ARE NOT INCLUDED IN SQUARE METRE (m²) AREAS
 ALL DISTANCES ARE IN METRES.

BB
 B.C.L.S.
 December 10, 1993.

PLAN OF S.L.'s 7-9 AND
COMMON PROPERTY

SHEET 11 OF 16 SHEETS

STRATA PLAN LMS

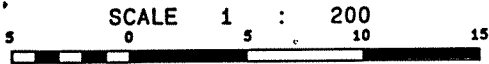

BUILDING 3
MAIN FLOOR

PROPERTY OF THE WHISTLER
REAL ESTATE CO. LTD.

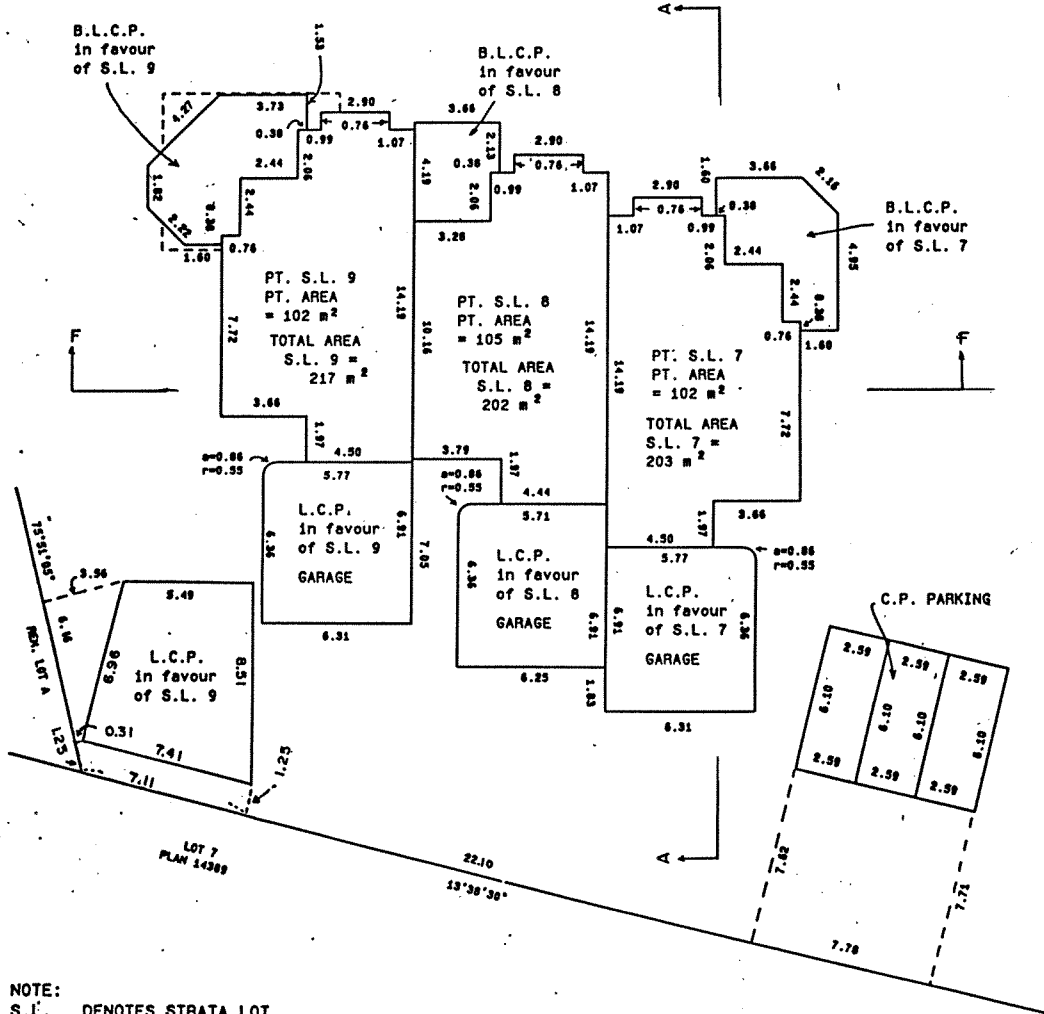

NOTE:
 S.L. DENOTES STRATA LOT
 C.P. DENOTES COMMON PROPERTY
 L.C.P. DENOTES LIMITED COMMON PROPERTY
 C.F. DENOTES COMMON FACILITY
 PT. DENOTES PART
 B. DENOTES BALCONY
 BALCONIES ARE COMMON PROPERTY AND ARE NOT INCLUDED IN SQUARE METRE (m²) AREAS
 ALL DISTANCES ARE IN METRES.

BB
 December 10, 1993. B.C.L.S.

PLAN OF S.L.'s 7-9 AND
COMMON PROPERTY

SHEET 12 OF 16 SHEETS

STRATA PLAN LMS

PROPERTY OF THE WHISTLER
REAL ESTATE CO. LTD.

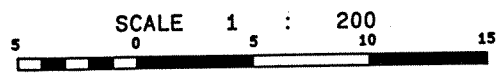

BUILDING 3
SECOND FLOOR

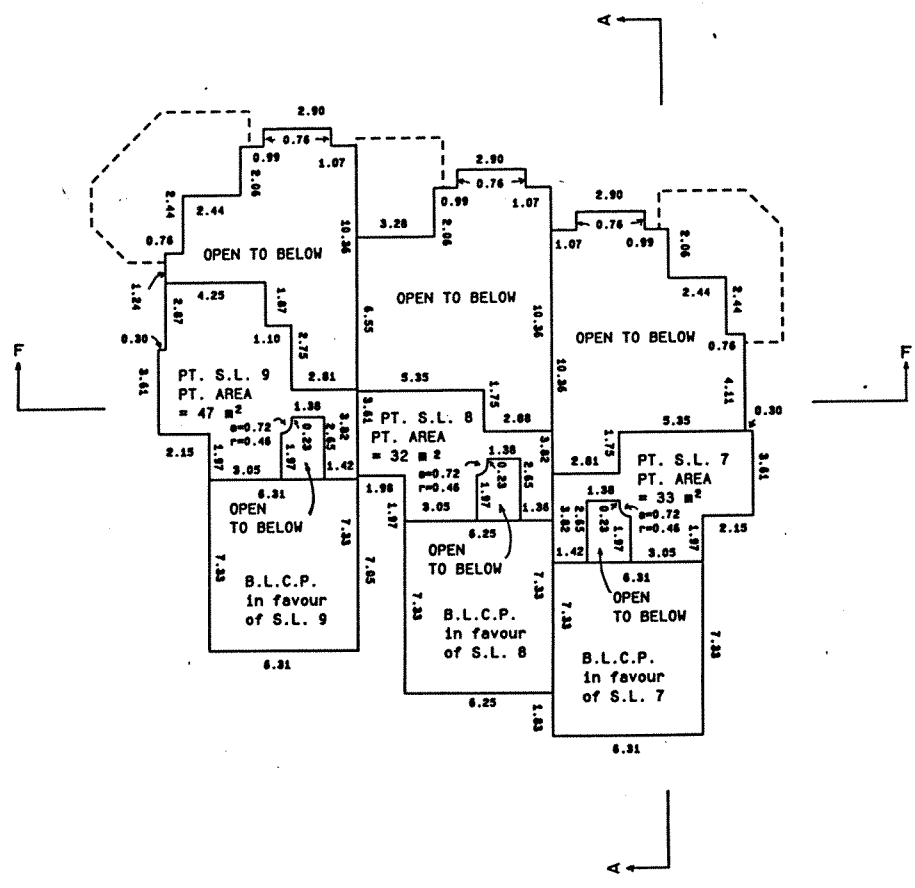

NOTE:
 S.L. DENOTES STRATA LOT
 C.P. DENOTES COMMON PROPERTY
 L.C.P. DENOTES LIMITED COMMON PROPERTY
 C.F. DENOTES COMMON FACILITY
 PT. DENOTES PART
 B. DENOTES BALCONY
 BALCONIES ARE COMMON PROPERTY AND ARE NOT INCLUDED IN SQUARE METRE (m²) AREAS
 ALL DISTANCES ARE IN METRES.

BB

December 10, 1993. B.C.L.S.

PROPERTY OF THE WHISTLER
REAL ESTATE CO. LTD.

CROSS-SECTIONS

STRATA PLAN LMS

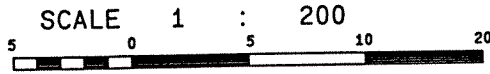

CROSS SECTION "A-A"

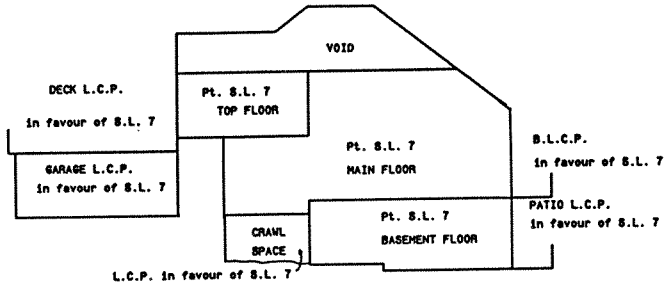

CROSS SECTION "B-B"

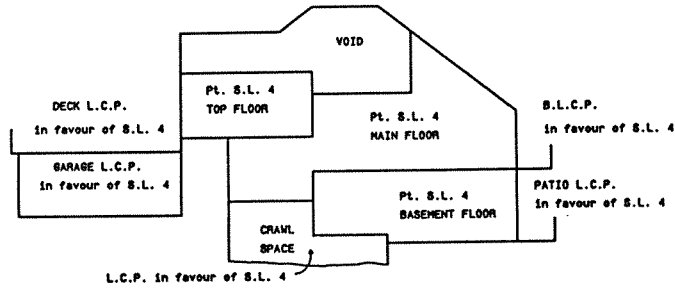

CROSS SECTION "C-C"

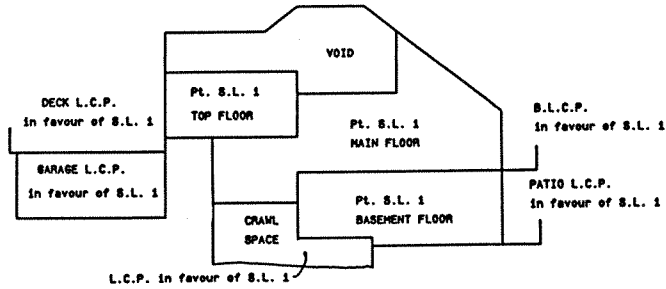

NOTE:
 S.L. DENOTES STRATA LOT
 C.P. DENOTES COMMON PROPERTY
 L.C.P. DENOTES LIMITED COMMON PROPERTY
 Pt. DENOTES PART
 B. DENOTES BALCONY
 BALCONIES ARE LIMITED COMMON PROPERTY AND ARE NOT INCLUDED IN SQUARE METRE (m²) AREAS
 ALL DISTANCES ARE IN METRES.

BB
 B.C.L.S.
 December 10, 1993.

PROPERTY OF THE WHISTLER
REAL ESTATE CO. LTD.

CROSS-SECTIONS

STRATA PLAN LMS

SCALE 1 : 200

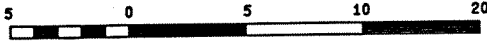

CROSS SECTION "D-D"

VOID	VOID	VOID
Pt. S.L. 3 TOP FLOOR	OPEN TO BELOW Pt. S.L. 2 TOP FLOOR	Pt. S.L. 1 TOP FLOOR
Pt. S.L. 3 MAIN FLOOR	Pt. S.L. 2 MAIN FLOOR	Pt. S.L. 1 MAIN FLOOR
CRAWL SPACE L.C.P. In favour of S.L. 3	CRAWL SPACE L.C.P. In favour of S.L. 2	CRAWL SPACE L.C.P. In favour of S.L. 1

Pt. S.L. 2
BASEMENT FLOOR

CROSS SECTION "E-E"

VOID	VOID	VOID
Pt. S.L. 6 TOP FLOOR	VOID	Pt. S.L. 4 MAIN FLOOR
Pt. S.L. 6 MAIN FLOOR	Pt. S.L. 5 MAIN FLOOR	
CRAWL SPACE L.C.P. In favour of S.L. 6	Pt. S.L. 5 BASEMENT FLOOR	Pt. S.L. 4 BASEMENT FLOOR

DECK's L.C.P.
In favour of S.L. 4

CROSS SECTION "F-F"

VOID	VOID	VOID
Pt. S.L. 9 TOP FLOOR	OPEN TO BELOW Pt. S.L. 8 TOP FLOOR	Pt. S.L. 7 MAIN FLOOR
Pt. S.L. 9 MAIN FLOOR	Pt. S.L. 8 MAIN FLOOR	
CRAWL SPACE L.C.P. In favour of S.L. 9	CRAWL SPACE L.C.P. In favour of S.L. 8	Pt. S.L. 7 BASEMENT FLOOR

Pt. S.L. 8 BASEMENT FLOOR

NOTE:
S.L. DENOTES STRATA LOT
C.P. DENOTES COMMON PROPERTY
L.C.P. DENOTES LIMITED COMMON PROPERTY
Pt. DENOTES PART
B. DENOTES BALCONY
BALCONIES ARE LIMITED COMMON PROPERTY AND ARE NOT INCLUDED IN SQUARE METRE (m²) AREAS
ALL DISTANCES ARE IN METRES.

BP
December 10, 1993.

B.C.L.S.

STRATA PLAN LMS

PROPERTY OF THE WHISTLER
REAL ESTATE CO. LTD.

RECORD OF BYLAWS AND ORDERS, ETC.

FILING		DOCUMENT	
NUMBER	DATE	DATE	NATURE AND PARTICULARS

BB
B.C.L.S.
December 10, 1993.

STRATA PLAN LMS

PROPERTY OF THE WHISTLER REAL ESTATE CO. LTD.

DEALINGS AFFECTING THE COMMON PROPERTY

FILING		DOCUMENT	
NUMBER	DATE	DATE	NATURE AND PARTICULARS

JB B.C.L.S.
December 10, 1993.