

FIRST SHEET SHEET 1 OF 48 SHEETS

STRATA PLAN OF LOT 73,
DISTRICT LOTS 4979 & 7179,
PLAN 20937, GP. 1, N.W.D.

STRATA PLAN VR 2325

DEPOSITED AND REGISTERED IN THE LAND
TITLE OFFICE AT VANCOUVER, B.C.,
THIS 15th DAY OF DECEMBER, 1988.

SCALE 1 : 500



THIS PLAN LIES WITHIN THE SQUAMISH-LILLOET REGIONAL DISTRICT
RESORT MUNICIPALITY OF WHISTLER

THE ADDRESS FOR SERVICE OF DOCUMENTS ON

THE STRATA CORPORATION IS:-

THE OWNERS STRATA PLAN VR 2325

C/O 2225 FOLKSTONE WAY

WEST VANCOUVER, B.C. V7S 2Y6

[Signature]
Deputy
REGISTRAR

GB 148243

CIVIC ADDRESS : 2640 WHISTLER ROAD

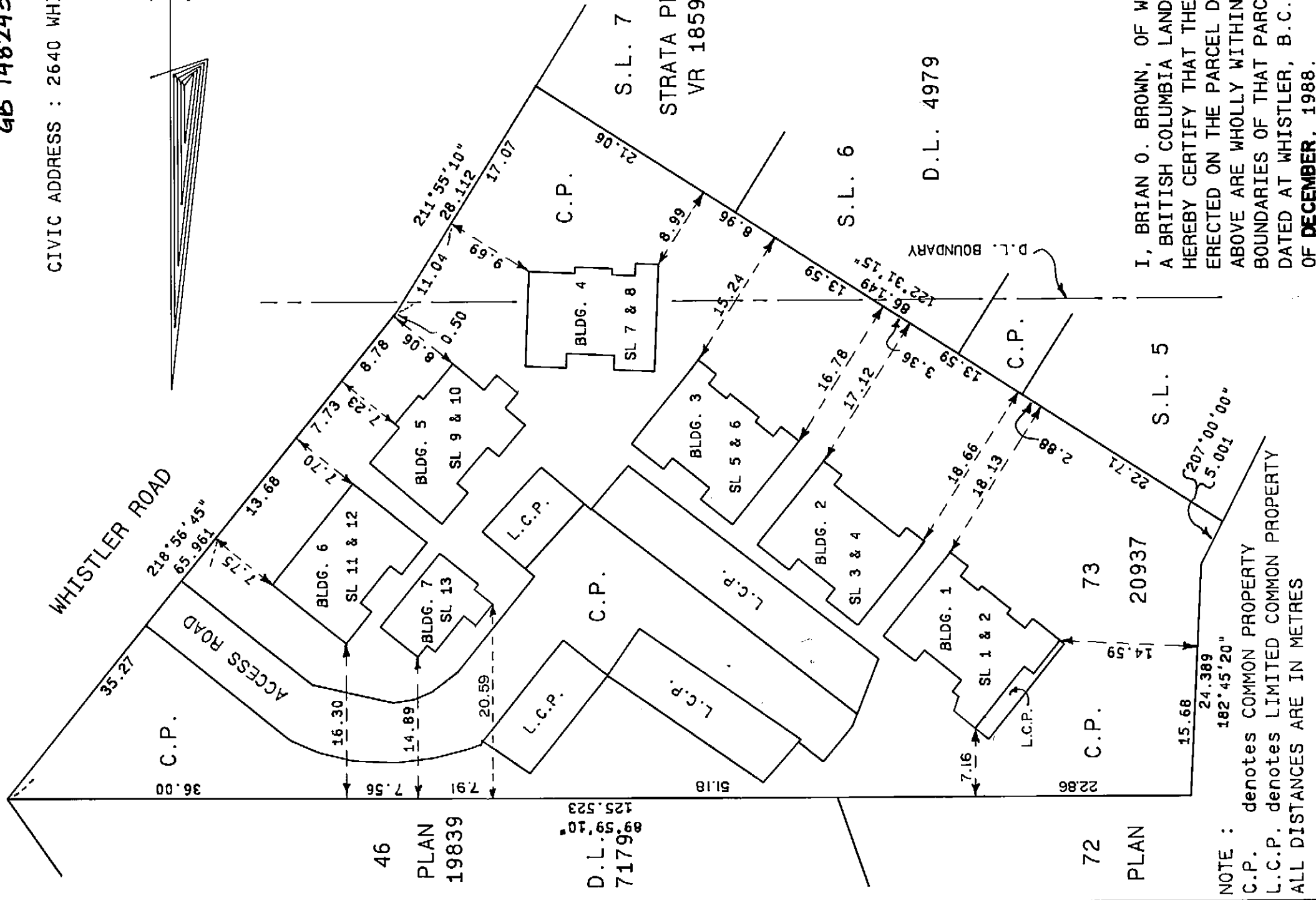
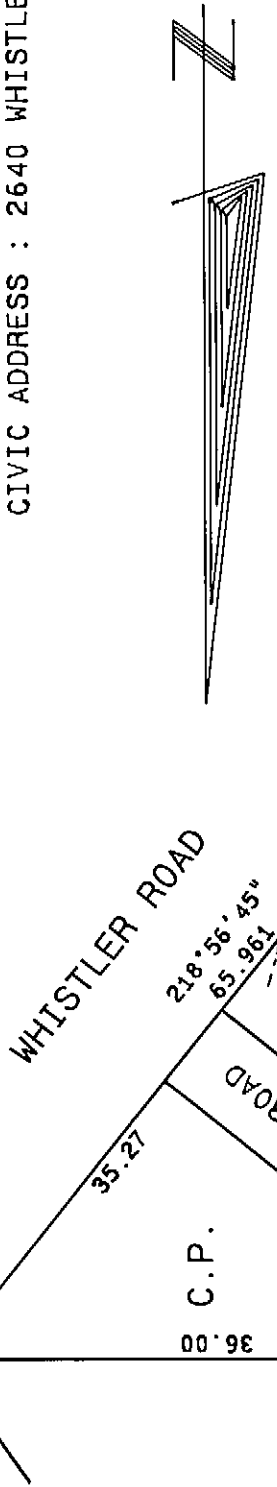

NOTE :
C.P. denotes COMMON PROPERTY
L.C.P. denotes LIMITED COMMON PROPERTY
ALL DISTANCES ARE IN METRES

I, BRIAN O. BROWN, OF WHISTLER, B.C.,
A BRITISH COLUMBIA LAND SURVEYOR,
HEREBY CERTIFY THAT THE BUILDINGS
ERECTED ON THE PARCEL DESCRIBED
ABOVE ARE WHOLLY WITHIN THE EXTERNAL
BOUNDARIES OF THAT PARCEL.
DATED AT WHISTLER, B.C. THIS 6th DAY
OF DECEMBER, 1988.

Robert B. Brown & Associates
Professional Land Surveyors
P.O. Box 13, Whistler, B.C.
V0N 1B0 932 - 5426

[Signature]
B.C.L.S.

SP88324B

J88092

SECOND SHEET SHEET 2 OF 48 SHEETS

CONDOMINIUM ACT

STRATA PLAN VR 2325

LOT NO.	SHEET NO.	FORM 1	FORM 2	FORM 3
		SECTION 3(1)(f) SCHEDULE OF UNIT ENTITLEMENT	SECTION 3(1)(g) SCHEDULE OF INTEREST UPON DESTRUCTION	SECTION 3(1)(h) SCHEDULE OF VOTING RIGHTS
		UNIT ENTITLEMENT	INTEREST UPON DESTRUCTION	NUMBER OF VOTES
1	4-7	783	7711	
2	4-7	783	7711	
3	8-11	748	7567	
4	8-11	748	7711	
5	12-15	783	7567	
6	12-15	783	7711	
7	16-19	783	7949	
8	16-19	783	7949	
9	20-23	783	7949	
10	20-23	783	7520	
11	24-27	747	7615	
12	24-27	747	7520	
13	28-31	746	7520	
AGGREGATE		10000	100000	

ACCEPTED AS TO FORMS 1, 2 & 3
This 2/ Day of December 1988.

[Signature]
SUPERINTENDENT OF REAL ESTATE

Robert B. Brown & Associates
Professional Land Surveyors
P.O. Box 13, Whistler, B.C.
V0N 1B0 932 - 5426

[Signature] B.C.L.S.
December 6 1988

SP88324B

J88092

SECOND SHEET SHEET 3 OF 48 SHEETS

CONDOMINIUM ACT

STRATA PLAN VR 2325

STATUTORY DECLARATION

I, THE UNDERSIGNED, DO SOLEMNLY DECLARE THAT:--

- (1) I, THE UNDERSIGNED, AM THE DULY AUTHORIZED AGENT OF THE OWNER DEVELOPER
 - (2) THE STRATA PLAN IS ENTIRELY FOR RESIDENTIAL USE
- I MAKE THIS SOLEMN DECLARATION CONSCIENTIOUSLY BELIEVING IT TO BE TRUE, AND KNOWING THAT IT IS OF THE SAME FORCE AND EFFECT AS IF MADE UNDER OATH.

DECLARED BEFORE ME AT - Vancouver
 IN THE PROVINCE OF BRITISH COLUMBIA
 THIS 12th DAY OF December, 1988.

BRIAN ESMOND McCREA
 101 - 2221 FOLKESTONE WAY
 WEST VANCOUVER, BRITISH COLUMBIA
 CANADA V7S 2Y6
 BARRISTER & SOLICITOR
 BUS (604) 926-4524 RES. 926-9075

 COMMISSIONER FOR TAKING AFFIDAVITS WITHIN THE
 PROVINCE OF BRITISH COLUMBIA

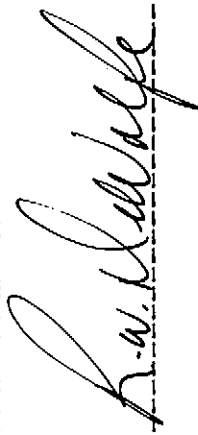

SIGNATURES

OWNERS
 INTERNATIONAL LAND CORPORATION LTD.

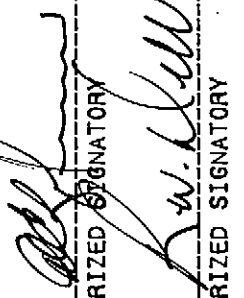

 AUTHORIZED SIGNATORY

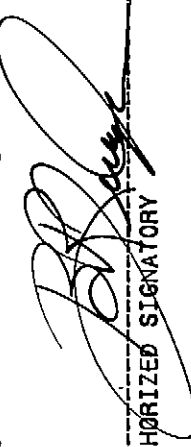
MORTGAGEE *Power of Attorney # GB/21889*
 THE TORONTO DOMINION BANK
 (By it's Attorneys in fact)

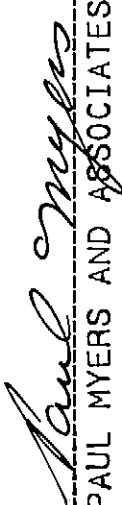
 AUTHORIZED SIGNATORY

 PAUL MYERS AND ASSOCIATES

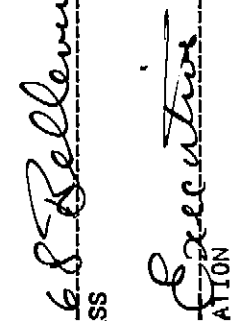
 WITNESS AS TO BOTH SIGNATURES
 Shirley Tatchell
 700 W. Georgia St.,
 Vancouver B.C.

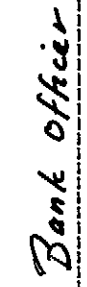

 2368 Bellevue Street
 V6C 1A6

 Bank Officer

I, BRIAN O. BROWN OF THE MUNICIPALITY OF WHISTLER, BRITISH COLUMBIA LAND SURVEYOR, HEREBY CERTIFY THAT THE BUILDINGS SHOWN IN THIS STRATA PLAN HAVE NOT, AS OF THE 6th DAY OF **DECEMBER**, 1988 BEEN PREVIOUSLY OCCUPIED. DATED AT WHISTLER, BRITISH COLUMBIA THIS 6th DAY OF **DECEMBER**, 1988.

 _____ B.C.L.S.

Robert B. Brown & Associates
 Professional Land Surveyors
 P.O. Box 13, Whistler, B.C.
 V0N 1B0 932 - 5426

 _____ B.C.L.S.
 December 6 1988

SP88324B

J88092

SHEET 4 OF 48 SHEETS

PLAN OF STRATA LOTS 1 & 2

STRATA PLAN VR 2325

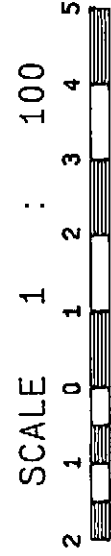

BUILDING 1

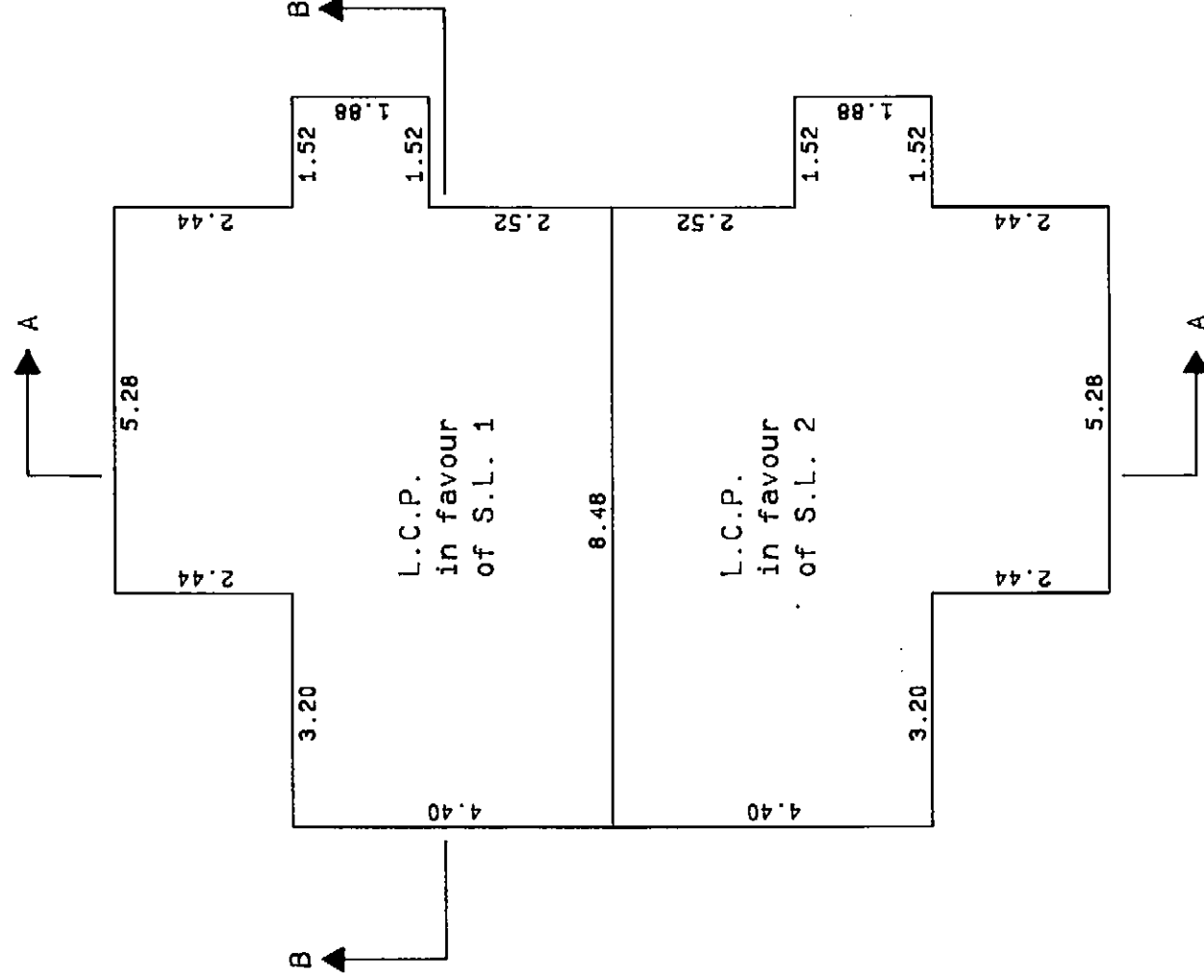
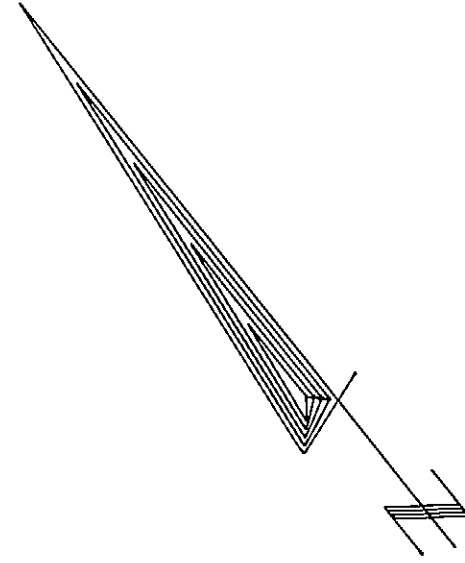

PLAN OF CRAWL SPACE

NOTE:

- S.L. DENOTES STRATA LOT
- C.P. DENOTES COMMON PROPERTY
- L.C.P. DENOTES LIMITED COMMON PROPERTY
- C.F. DENOTES COMMON FACILITY
- PT. DENOTES PART
- B. DENOTES BALCONY

BALCONIES ARE COMMON PROPERTY AND ARE NOT INCLUDED IN SQUARE METRE (M²) AREAS

ALL DISTANCES ARE IN METRES.

JP

December 6 1988

B.C.L.S.

J88092

SP88324B

SHEET 5 OF 48 SHEETS

PLAN OF STRATA LOTS 1 & 2

STRATA PLAN VR 2325

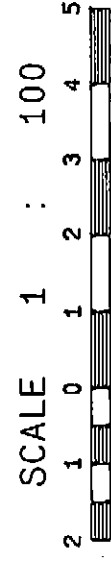

BUILDING 1

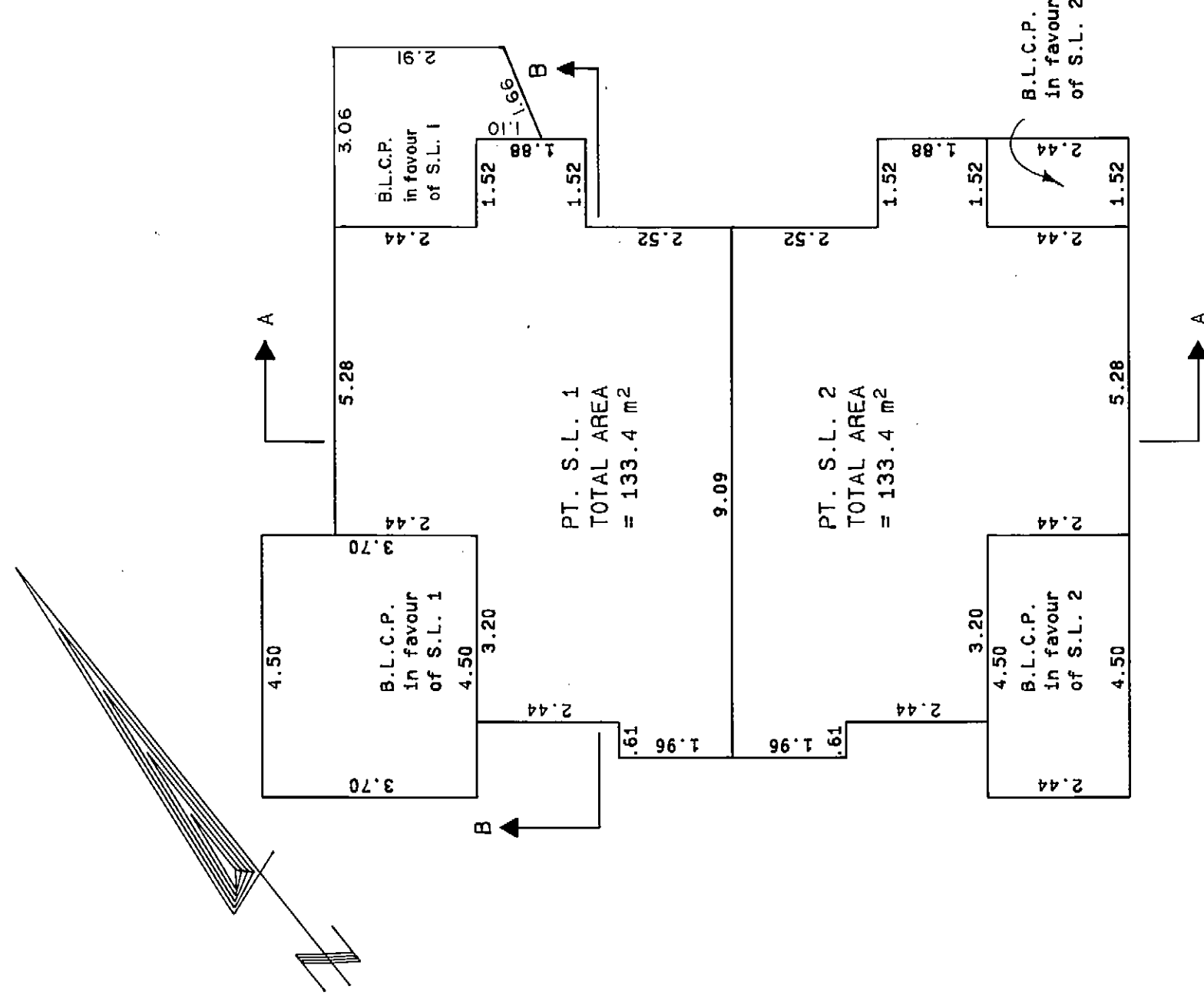

PLAN OF GROUND FLOOR

NOTE:

- S.L. DENOTES STRATA LOT
- C.P. DENOTES COMMON PROPERTY
- L.C.P. DENOTES LIMITED COMMON PROPERTY
- C.F. DENOTES COMMON FACILITY
- PT. DENOTES PART
- B. DENOTES BALCONY
- BALCONIES ARE COMMON PROPERTY AND ARE NOT INCLUDED IN SQUARE METRE (M²) AREAS
- ALL DISTANCES ARE IN METRES.

BB
 December 6 1988
 B.C.L.S.

J88092

SP88324B

SHEET 6 OF 48 SHEETS

PLAN OF STRATA LOTS 1 & 2

STRATA PLAN VR 2325

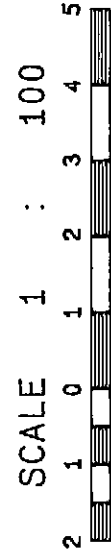

BUILDING 1

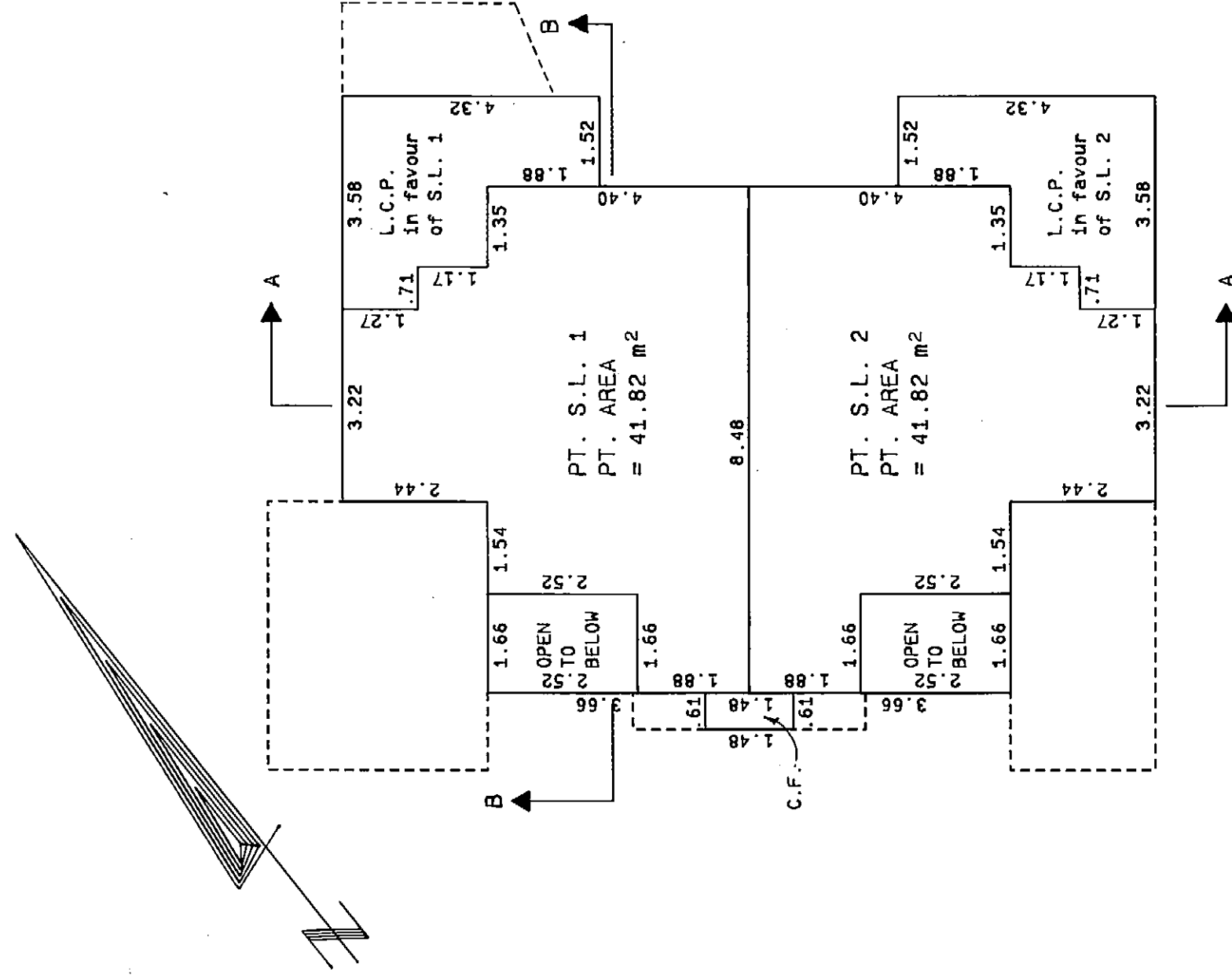

PLAN OF SECOND FLOOR

NOTE:
 S.L. DENOTES STRATA LOT
 C.P. DENOTES COMMON PROPERTY
 L.C.P. DENOTES LIMITED COMMON PROPERTY
 C.F. DENOTES COMMON FACILITY
 PT. DENOTES PART
 B. DENOTES BALCONY
 BALCONIES ARE COMMON PROPERTY AND ARE NOT INCLUDED IN SQUARE METRE (M²) AREAS
 ALL DISTANCES ARE IN METRES.

PP
 December 6 1988
 B.C.L.S.

J88092

SP86324B

SHEET 7 OF 48 SHEETS

PLAN OF STRATA LOTS 1 & 2

STRATA PLAN VR 2325

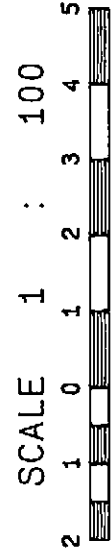

BUILDING 1

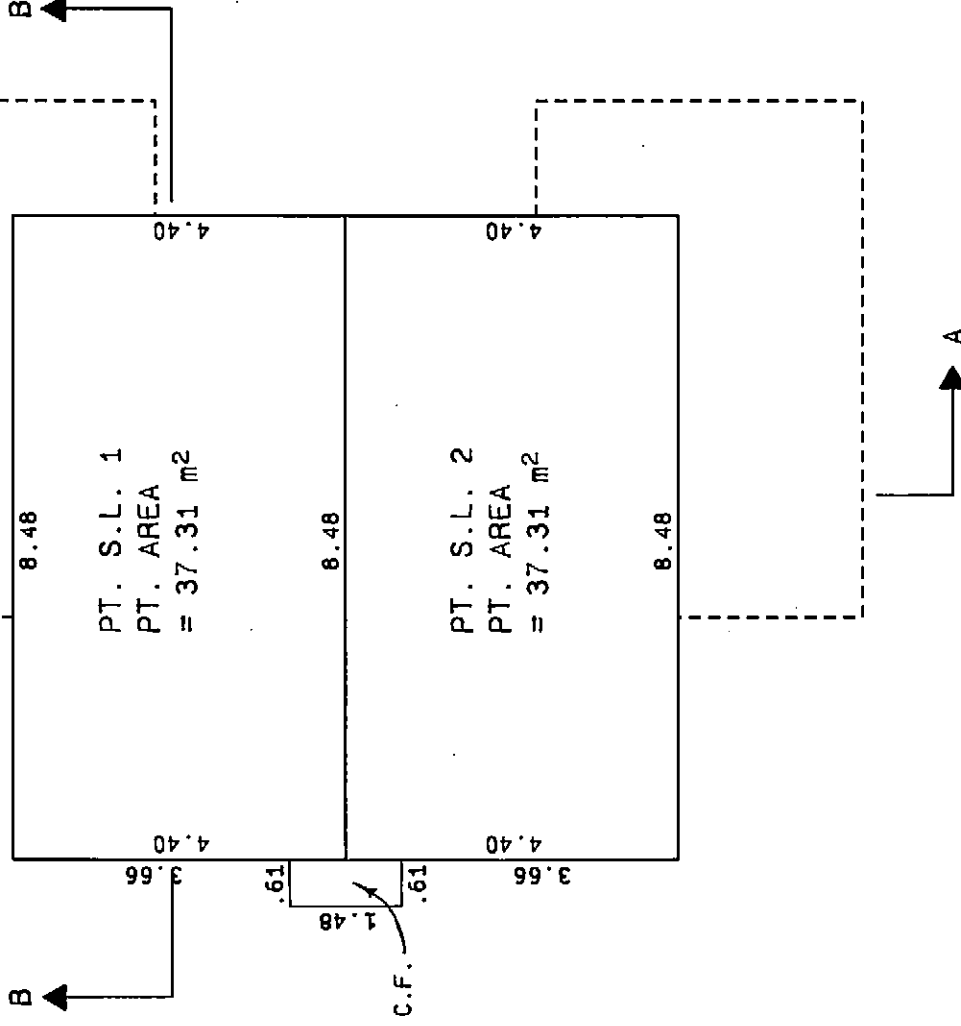
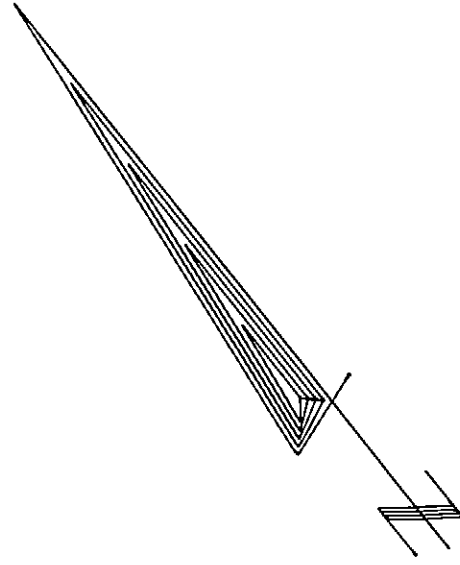

PLAN OF THIRD FLOOR

NOTE:
 S.L. DENOTES STRATA LOT
 C.P. DENOTES COMMON PROPERTY
 L.C.P. DENOTES LIMITED COMMON PROPERTY
 C.F. DENOTES COMMON FACILITY
 PT. DENOTES PART
 B. DENOTES BALCONY
 BALCONIES ARE COMMON PROPERTY AND ARE NOT INCLUDED IN SQUARE METRE (M²) AREAS
 ALL DISTANCES ARE IN METRES.

BP
 December 6 1988
 B.C.L.S.

J88092

SP88324B

SHEET 8 OF 48 SHEETS

PLAN OF STRATA LOTS 3 & 4

STRATA PLAN VR 2325

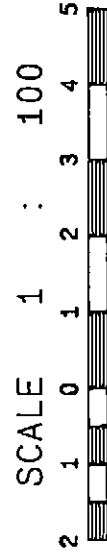

BUILDING 2

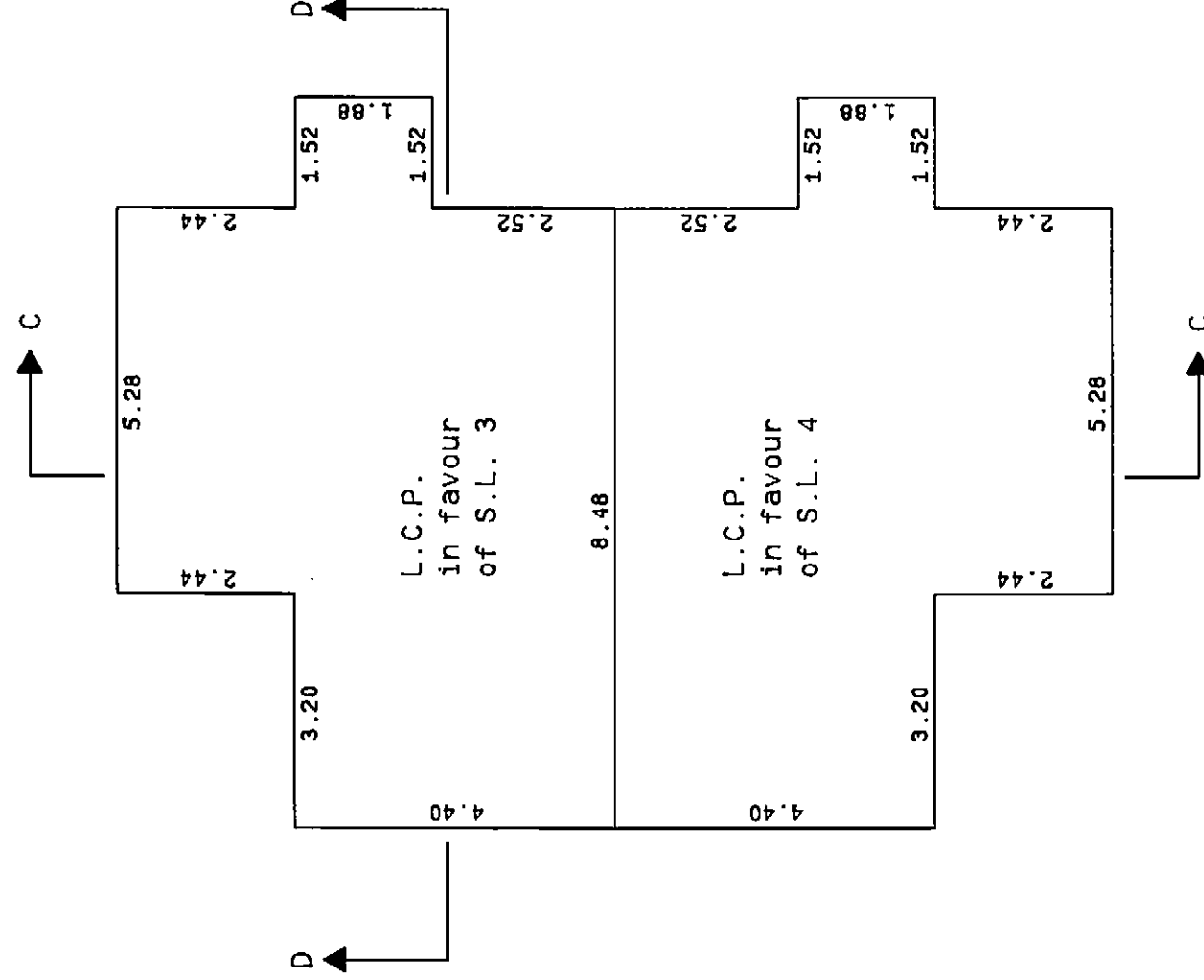
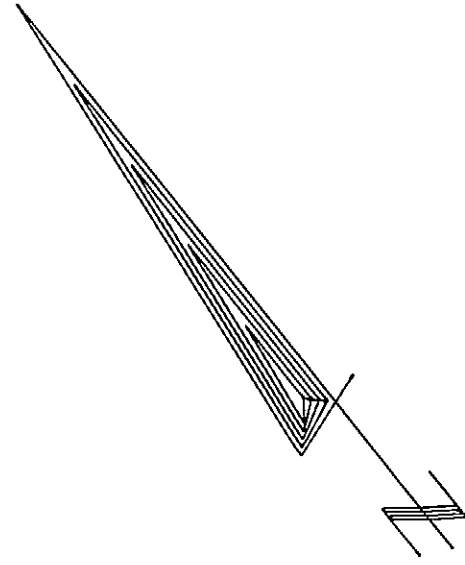

PLAN OF CRAWL SPACE

NOTE:
 S.L. DENOTES STRATA LOT
 C.P. DENOTES COMMON PROPERTY
 L.C.P. DENOTES LIMITED COMMON PROPERTY
 C.F. DENOTES COMMON FACILITY
 PT. DENOTES PART
 B. DENOTES BALCONY
 BALCONIES ARE COMMON PROPERTY AND ARE NOT INCLUDED IN SQUARE METRE (M²) AREAS
 ALL DISTANCES ARE IN METRES.

BB
 December 6 1988
 B.C.L.S.

J88092

SP88324B

SHEET 9 OF 48 SHEETS

PLAN OF STRATA LOTS 3 & 4

STRATA PLAN VR 2325

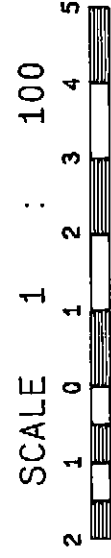

BUILDING 2

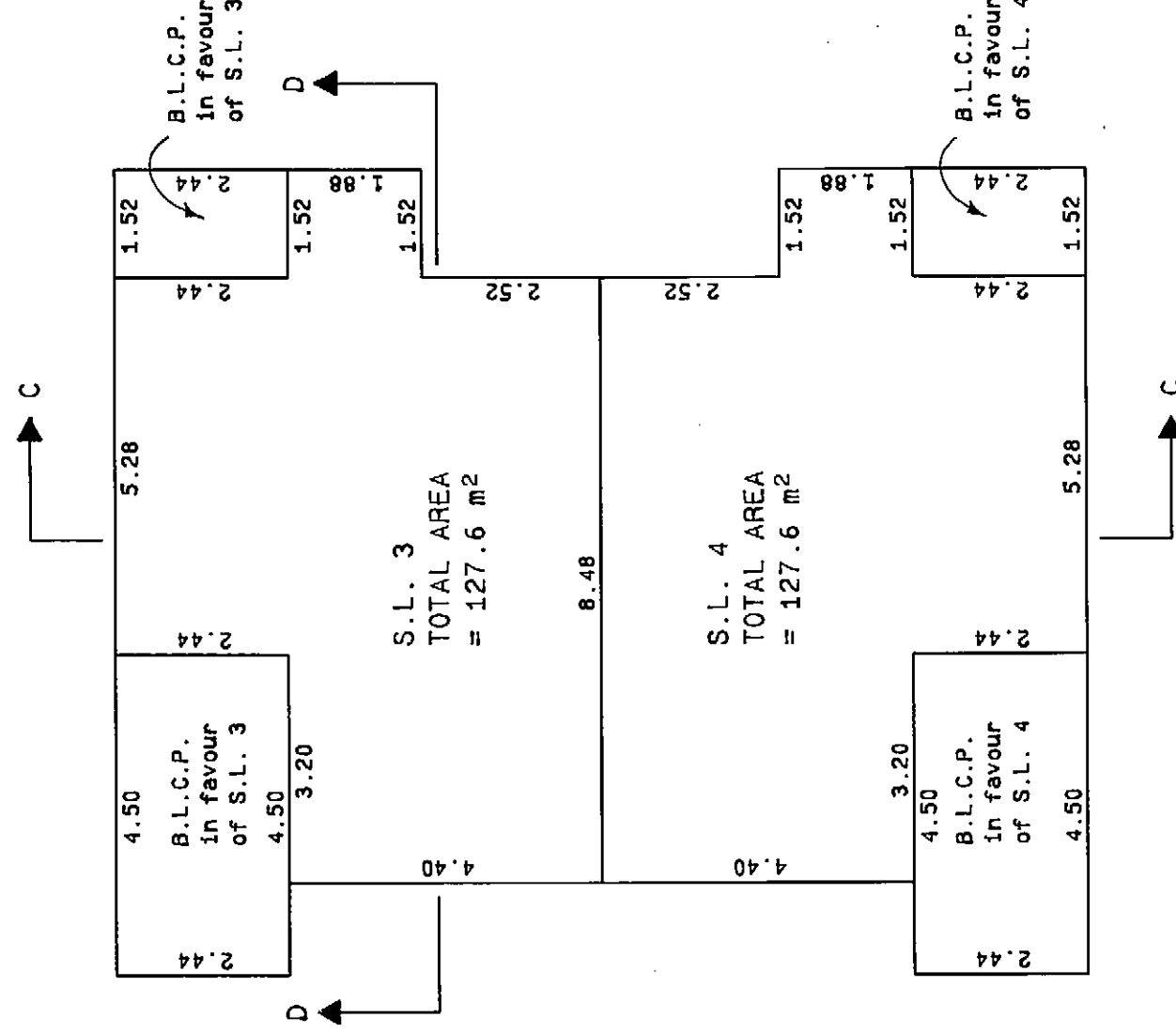
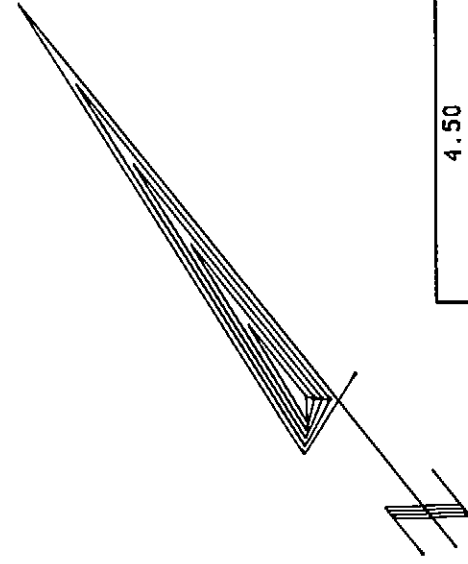

PLAN OF GROUND FLOOR

- NOTE:
- S.L. DENOTES STRATA LOT
 - C.P. DENOTES COMMON PROPERTY
 - L.C.P. DENOTES LIMITED COMMON PROPERTY
 - C.F. DENOTES COMMON FACILITY
 - PT. DENOTES PART
 - B. DENOTES BALCONY
 - BALCONIES ARE COMMON PROPERTY AND ARE NOT INCLUDED IN SQUARE METRE (M²) AREAS
 - ALL DISTANCES ARE IN METRES.

BB

 December 6 1988
 B.C.L.S.

J88092

SP88324B

SHEET 10 OF 48 SHEETS

PLAN OF STRATA LOTS 3 & 4

STRATA PLAN VR 2325

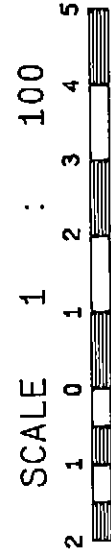

BUILDING 2

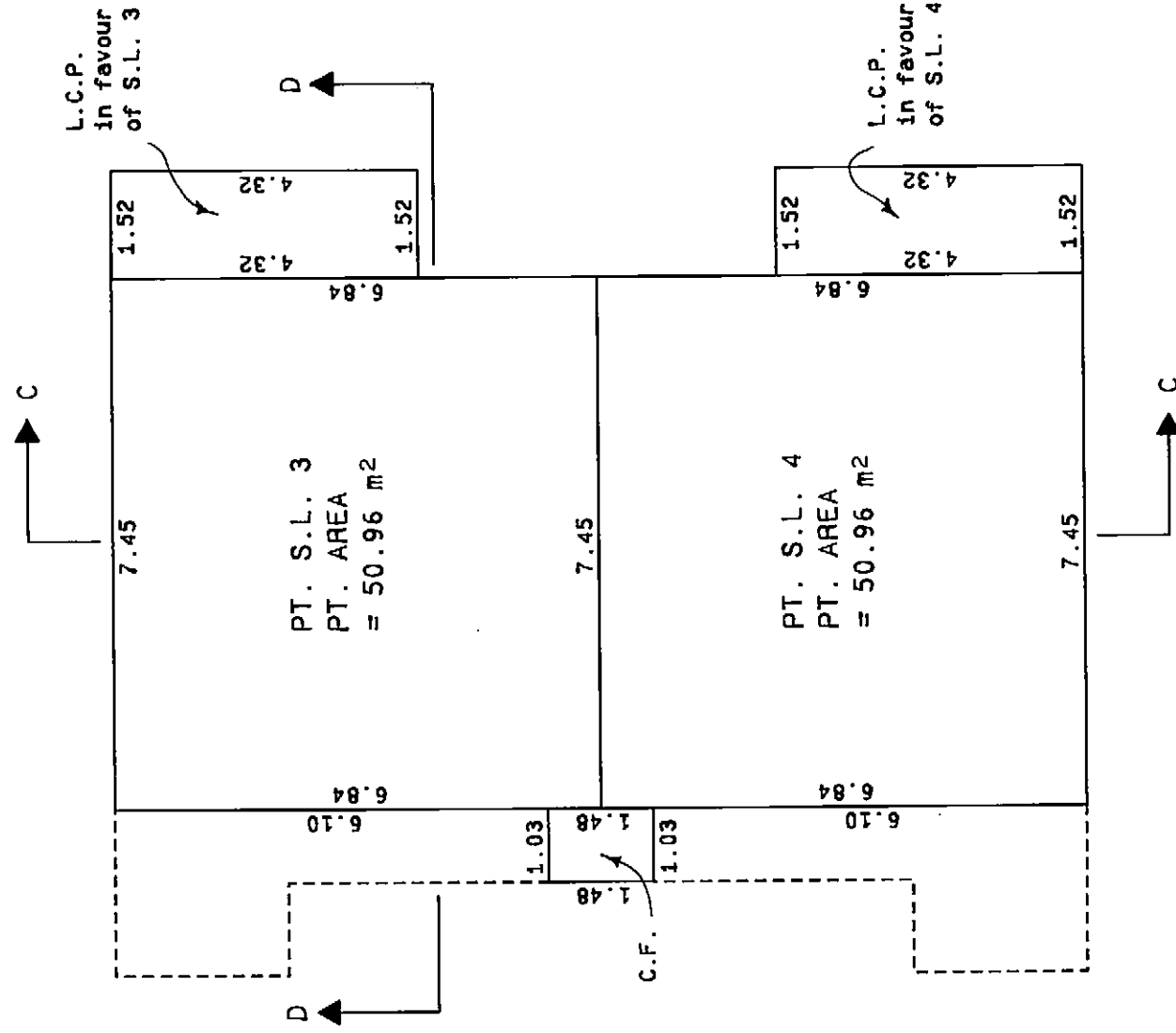
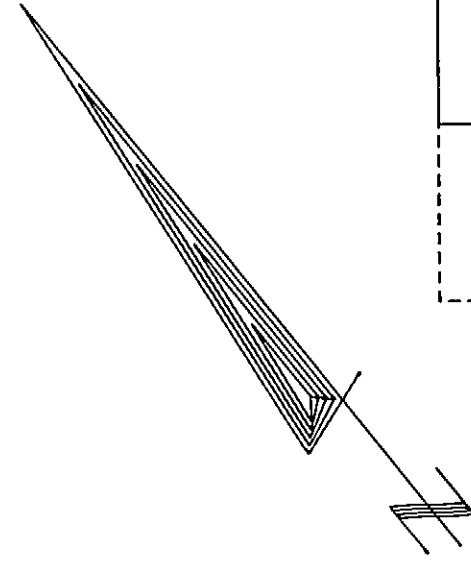

PLAN OF SECOND FLOOR

NOTE:
 S.L. DENOTES STRATA LOT
 C.P. DENOTES COMMON PROPERTY
 L.C.P. DENOTES LIMITED COMMON PROPERTY
 C.F. DENOTES COMMON FACILITY
 PT. DENOTES PART
 B. DENOTES BALCONY
 BALCONIES ARE COMMON PROPERTY AND ARE NOT INCLUDED IN SQUARE METRE (M²) AREAS
 ALL DISTANCES ARE IN METRES.

BB
 December 6
 B.C.L.S.
 1988

J88092

SP88324B

SHEET 11 OF 48 SHEETS

PLAN OF STRATA LOTS 3 & 4

STRATA PLAN VR 2325

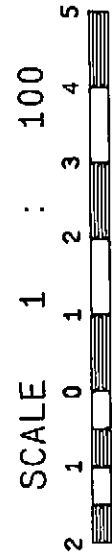

BUILDING 2

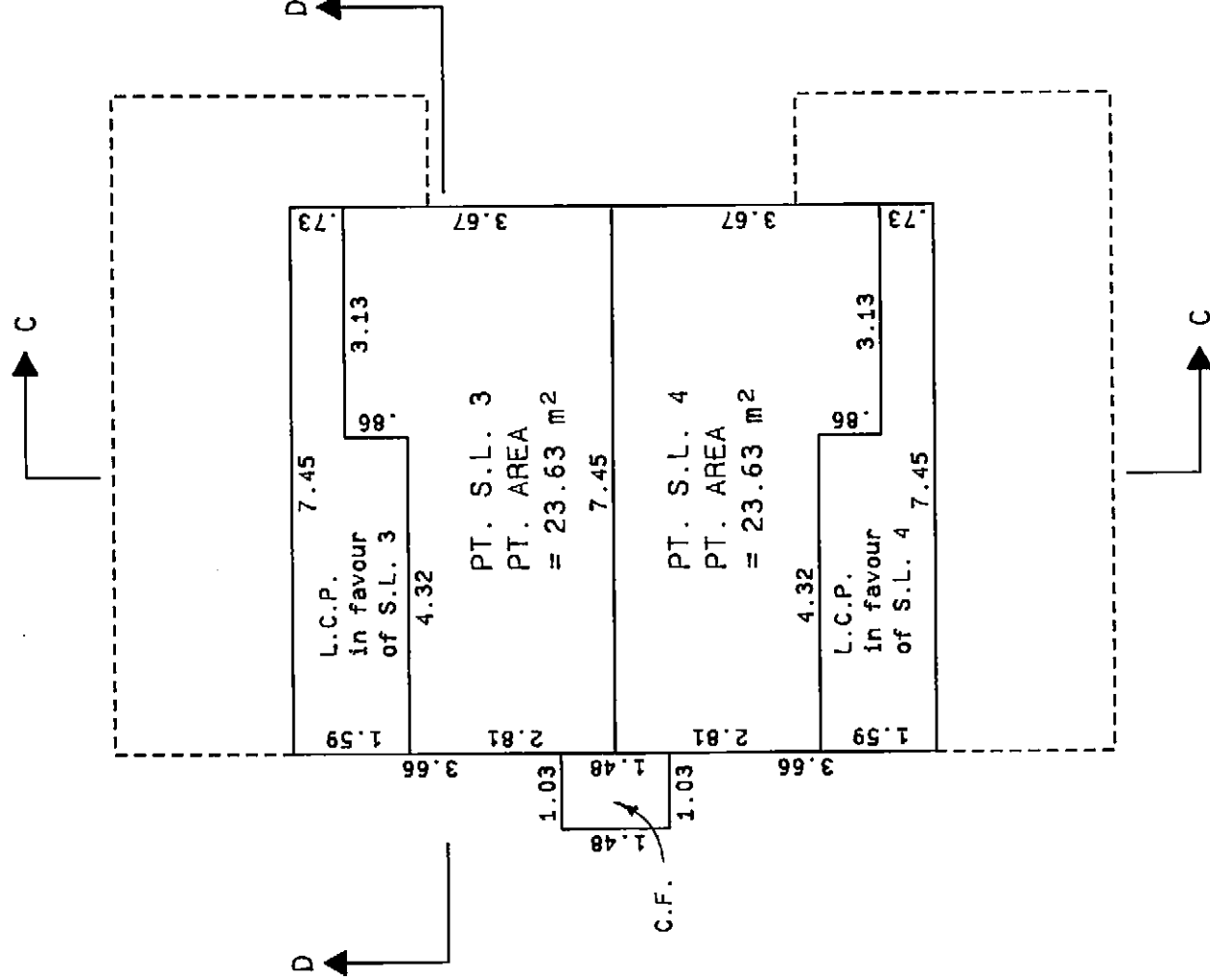
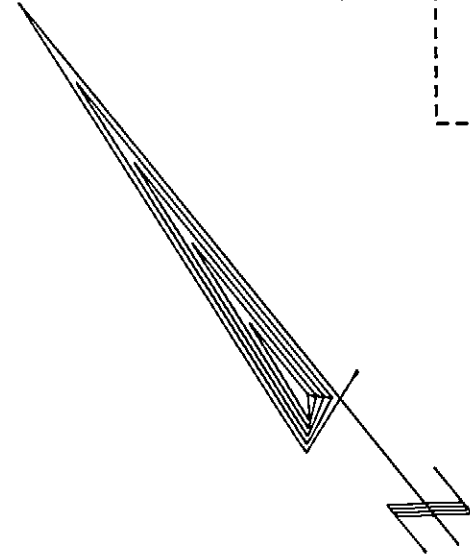

PLAN OF THIRD FLOOR

NOTE:

- S.L. DENOTES STRATA LOT
- C.P. DENOTES COMMON PROPERTY
- L.C.P. DENOTES LIMITED COMMON PROPERTY
- C.F. DENOTES COMMON FACILITY
- PT. DENOTES PART
- B. DENOTES BALCONY
- BALCONIES ARE COMMON PROPERTY AND ARE NOT INCLUDED IN SQUARE METRE (M²) AREAS
- ALL DISTANCES ARE IN METRES.

BB

 December 6

 B.C.L.S. 1988

J88092

SP88324B

SHEET 12 OF 48 SHEETS

PLAN OF STRATA LOTS 5 & 6

STRATA PLAN VR 2325

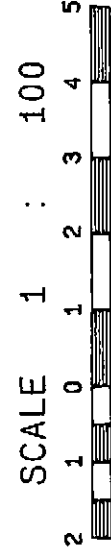

BUILDING 3

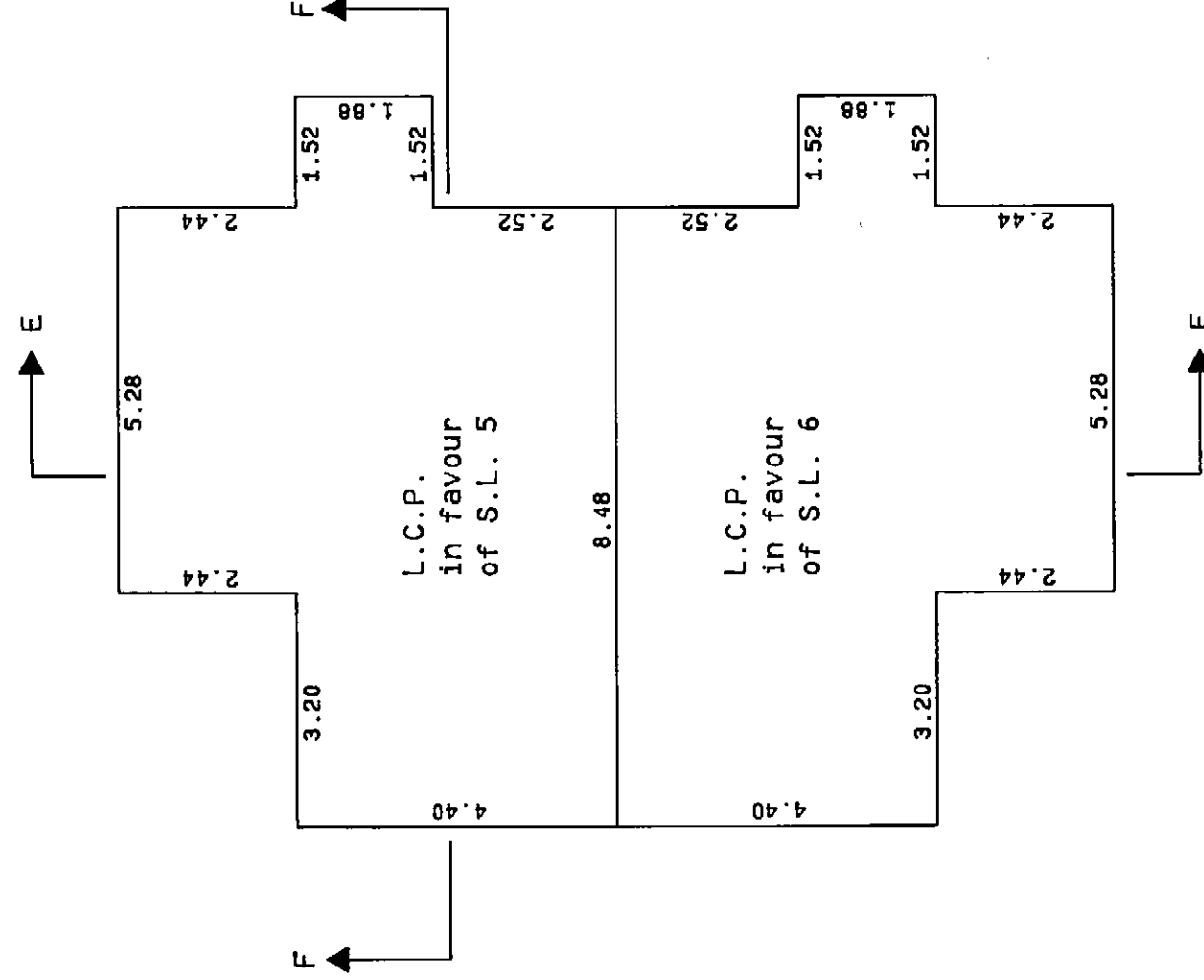
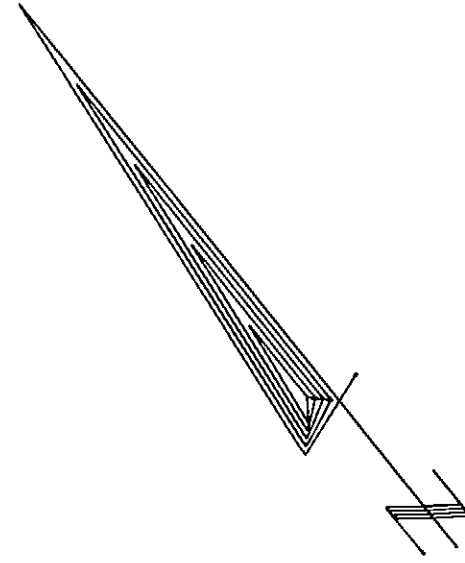

PLAN OF CRAWL SPACE

NOTE:
 S.L. DENOTES STRATA LOT
 C.P. DENOTES COMMON PROPERTY
 L.C.P. DENOTES LIMITED COMMON PROPERTY
 C.F. DENOTES COMMON FACILITY
 PT. DENOTES PART
 B. DENOTES BALCONY
 BALCONIES ARE COMMON PROPERTY AND ARE NOT INCLUDED IN SQUARE METRE (M²) AREAS
 ALL DISTANCES ARE IN METRES.

BB
 December 6 1988
 B.C.L.S.

J88092

SP88324B

SHEET 13 OF 48 SHEETS

PLAN OF STRATA LOTS 5 & 6

STRATA PLAN VR 2325

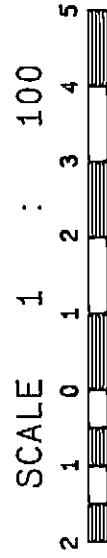

BUILDING 3

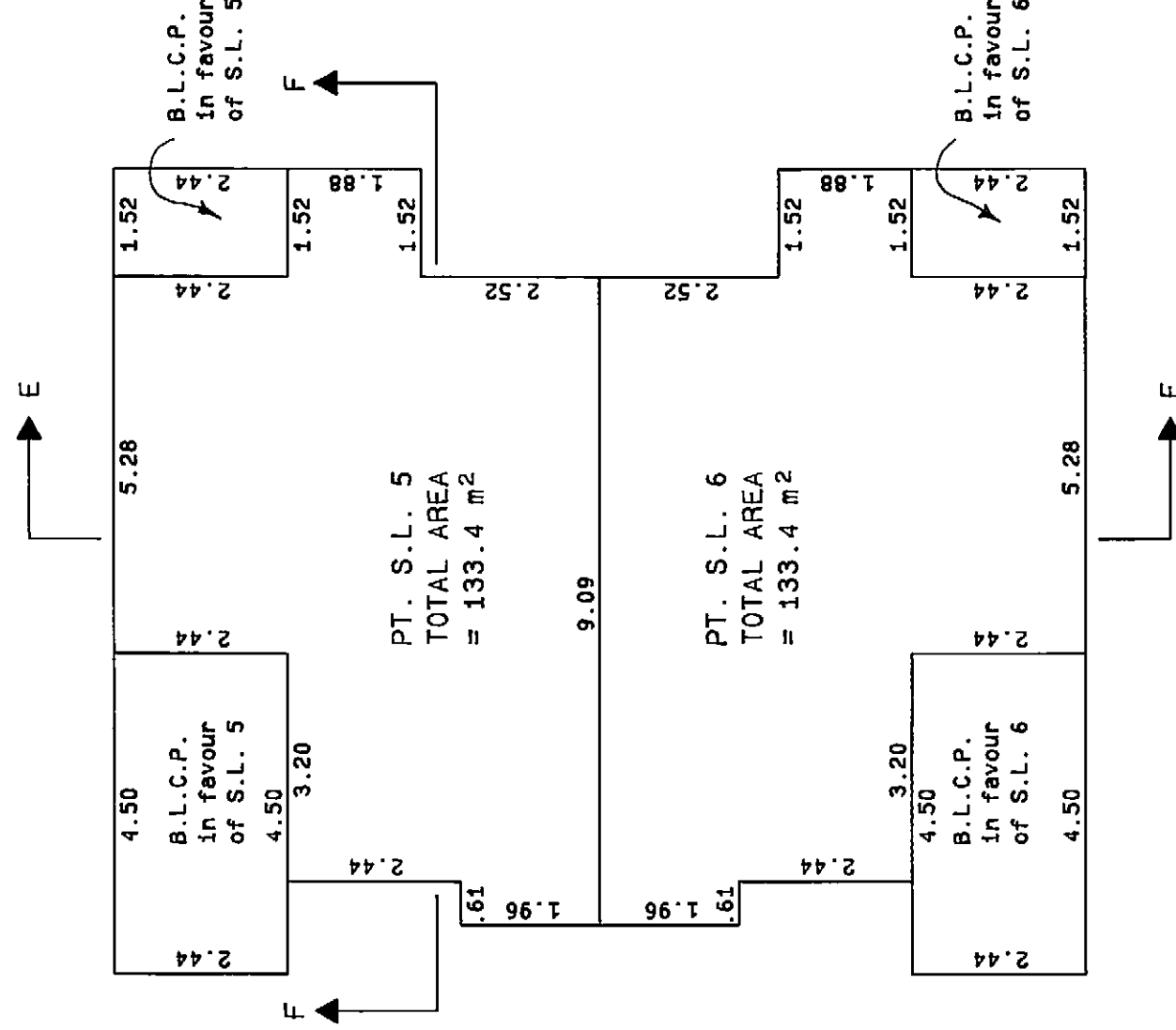
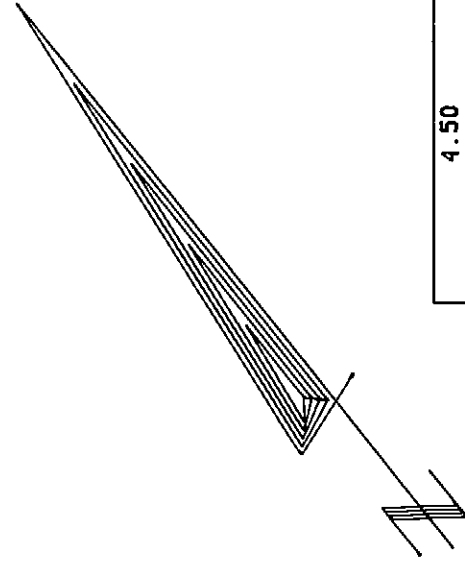

PLAN OF GROUND FLOOR

NOTE:
 S.L. DENOTES STRATA LOT
 C.P. DENOTES COMMON PROPERTY
 L.C.P. DENOTES LIMITED COMMON PROPERTY
 C.F. DENOTES COMMON FACILITY
 PT. DENOTES PART
 B. DENOTES BALCONY
 BALCONIES ARE COMMON PROPERTY AND ARE NOT INCLUDED IN SQUARE METRE (M²) AREAS
 ALL DISTANCES ARE IN METRES.

BB
 December 6 1988
 B.C.L.S.

J88092

SP88324B

SHEET 14 OF 48 SHEETS

PLAN OF STRATA LOTS 5 & 6

STRATA PLAN VR 2325

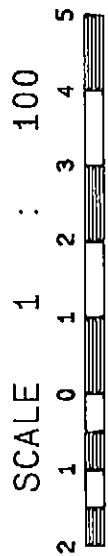

BUILDING 3

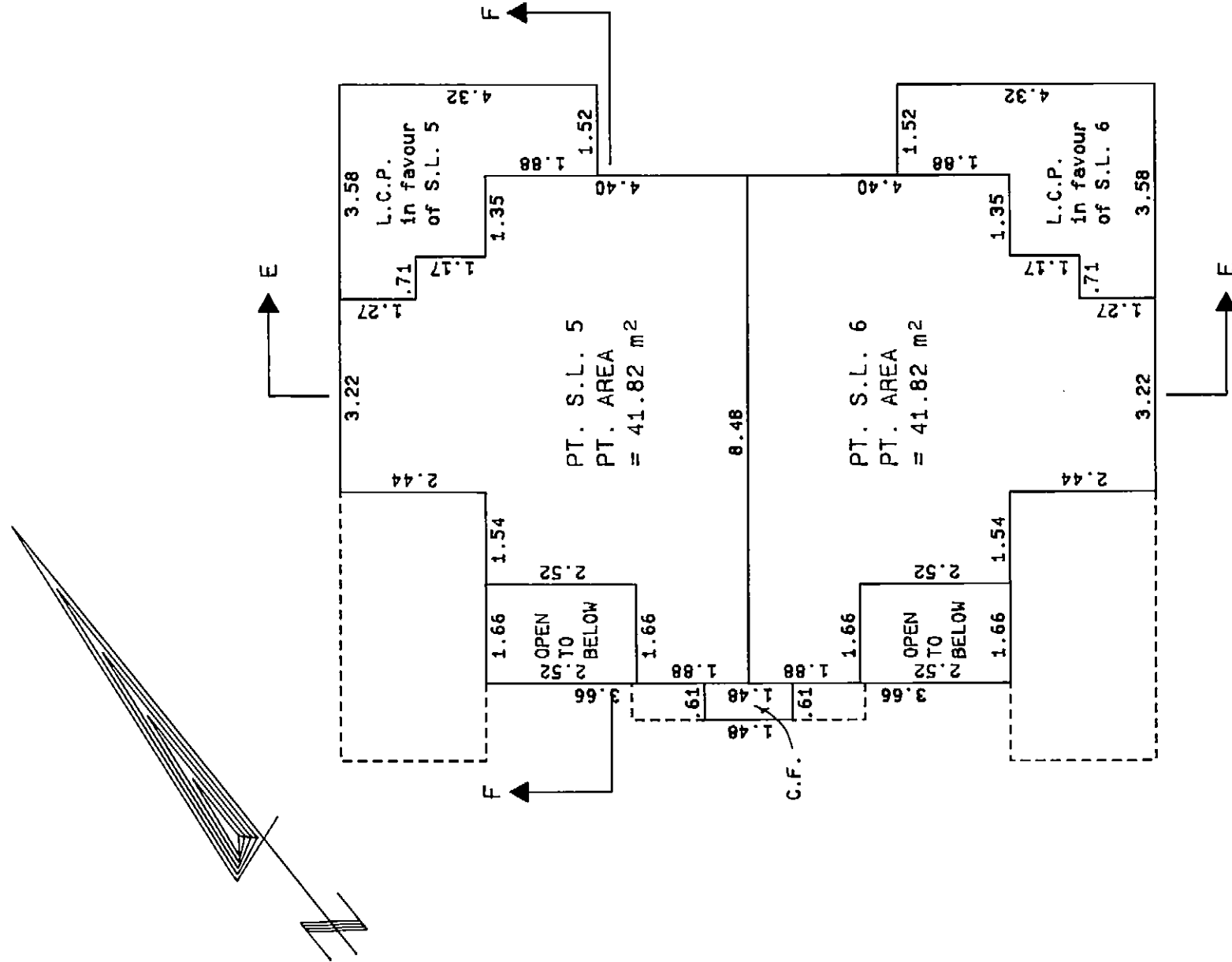

PLAN OF SECOND FLOOR

- NOTE:
- S.L. DENOTES STRATA LOT
 - C.P. DENOTES COMMON PROPERTY
 - L.C.P. DENOTES LIMITED COMMON PROPERTY
 - C.F. DENOTES COMMON FACILITY
 - PT. DENOTES PART
 - B. DENOTES BALCONY
- BALCONIES ARE COMMON PROPERTY AND ARE NOT INCLUDED IN SQUARE METRE (M²) AREAS
 ALL DISTANCES ARE IN METRES.

BB

 B.C.L.S.
 December 6 1988

J88092

SP88324B

SHEET 15 OF 48 SHEETS

PLAN OF STRATA LOTS 5 & 6

STRATA PLAN VR 2325

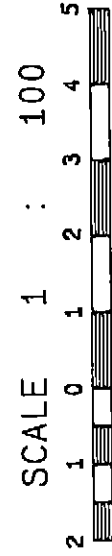

BUILDING 3

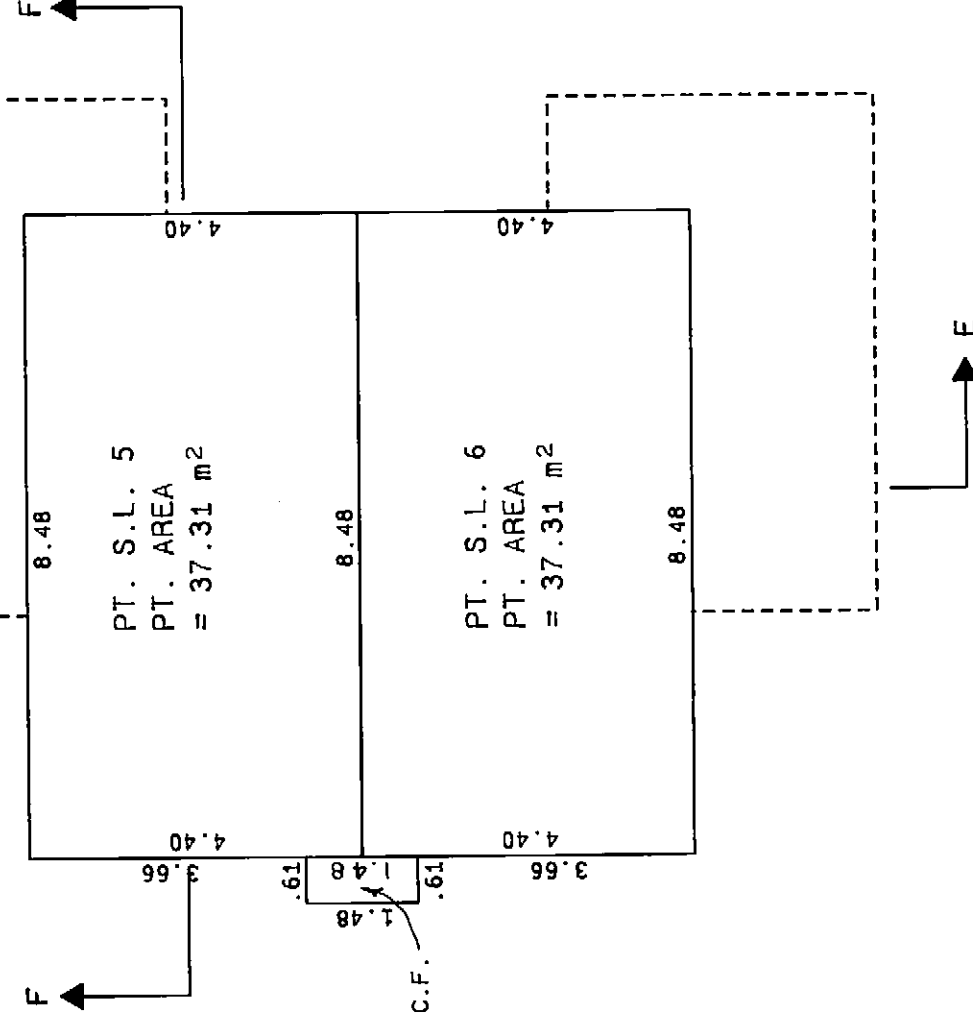
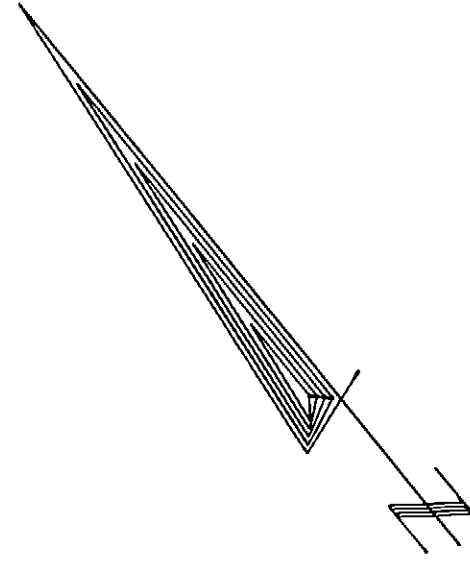

PLAN OF THIRD FLOOR

NOTE:
 S.L. DENOTES STRATA LOT
 C.P. DENOTES COMMON PROPERTY
 L.C.P. DENOTES LIMITED COMMON PROPERTY
 C.F. DENOTES COMMON FACILITY
 PT. DENOTES PART
 B. DENOTES BALCONY
 BALCONIES ARE COMMON PROPERTY AND ARE NOT INCLUDED IN SQUARE METRE (M²) AREAS
 ALL DISTANCES ARE IN METRES.

[Signature]
 _____ B.C.L.S.
 December 6 1988

J88092

SP88324B

SHEET 16 OF 48 SHEETS

PLAN OF STRATA LOTS 7 & 8

STRATA PLAN VR 2325



BUILDING 4

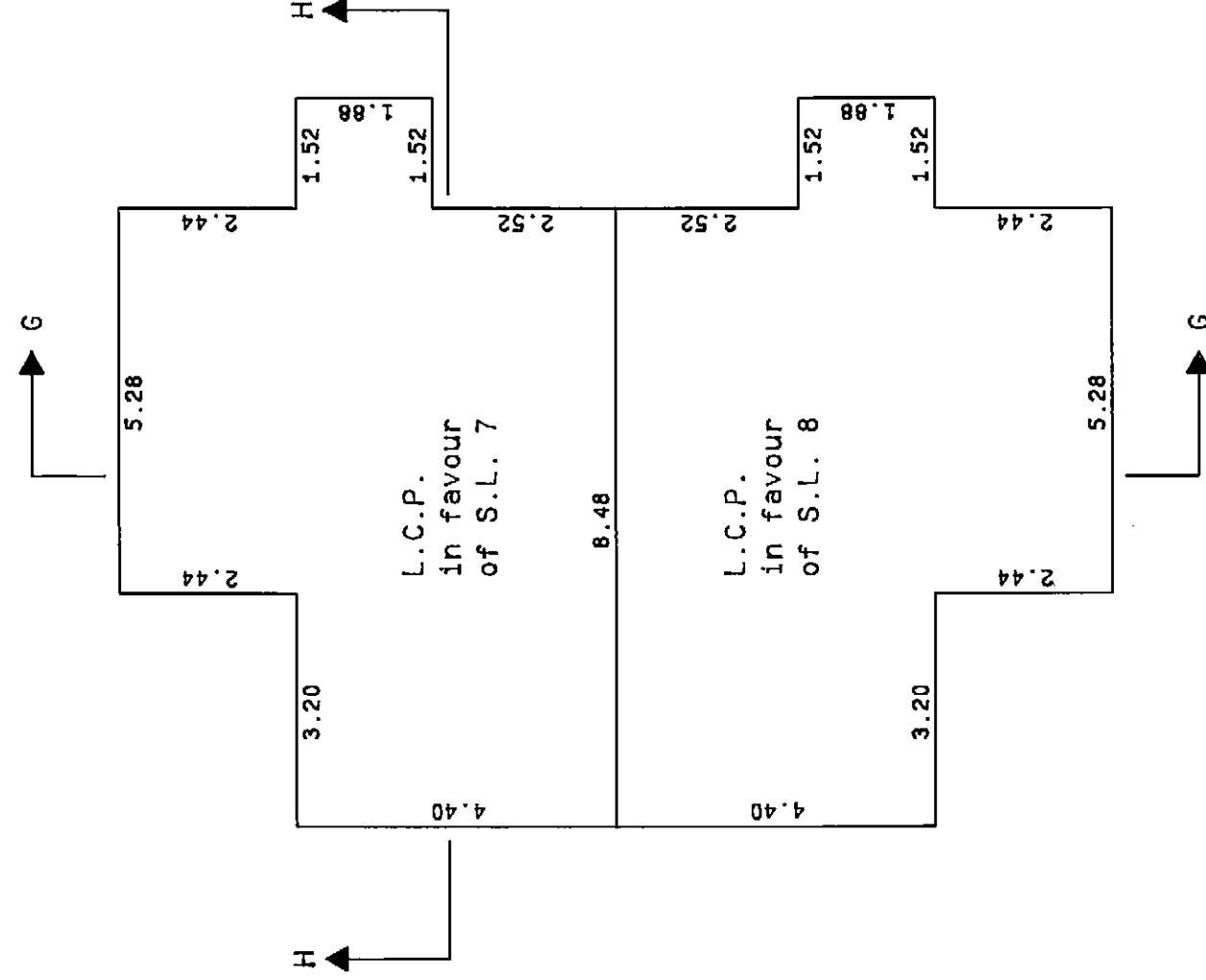
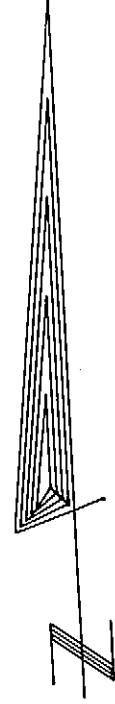

PLAN OF CRAWL SPACE

NOTE:
 S.L. DENOTES STRATA LOT
 C.P. DENOTES COMMON PROPERTY
 L.C.P. DENOTES LIMITED COMMON PROPERTY
 C.F. DENOTES COMMON FACILITY
 PT. DENOTES PART
 B. DENOTES BALCONY
 BALCONIES ARE COMMON PROPERTY AND ARE NOT INCLUDED IN SQUARE METRE (M²) AREAS
 ALL DISTANCES ARE IN METRES.

BB

 December 6 1988

 B.C.L.S.

J88092

SP88324B

SHEET 17 OF 48 SHEETS

PLAN OF STRATA LOTS 7 & 8

STRATA PLAN VR 2325



BUILDING 4

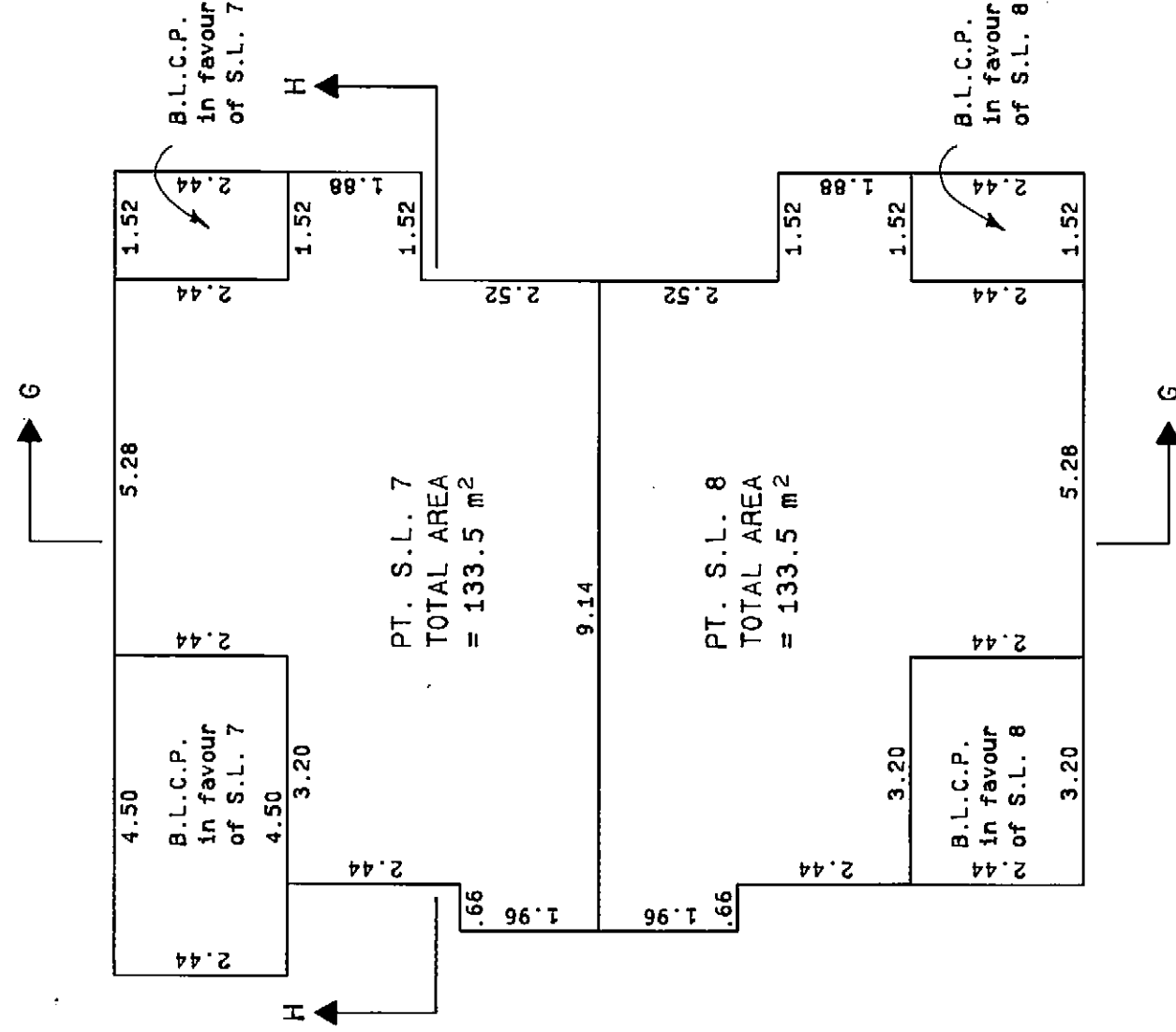
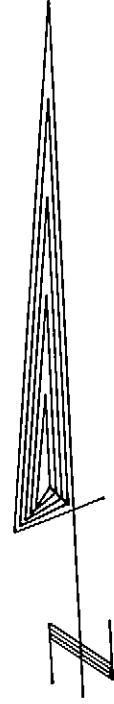

PLAN OF GROUND FLOOR

NOTE:

- S.L. DENOTES STRATA LOT
- C.P. DENOTES COMMON PROPERTY
- L.C.P. DENOTES LIMITED COMMON PROPERTY
- C.F. DENOTES COMMON FACILITY
- PT. DENOTES PART
- B. DENOTES BALCONY

BALCONIES ARE COMMON PROPERTY AND ARE NOT INCLUDED IN SQUARE METRE (M²) AREAS
ALL DISTANCES ARE IN METRES.

RP

 December 6 1988
 B.C.L.S.

J88092

SP88324B

SHEET 18 OF 48 SHEETS

PLAN OF STRATA LOTS 7 & 8

STRATA PLAN VR 2325

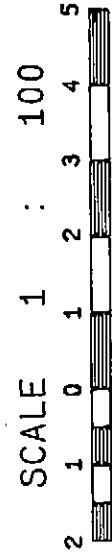

BUILDING 4

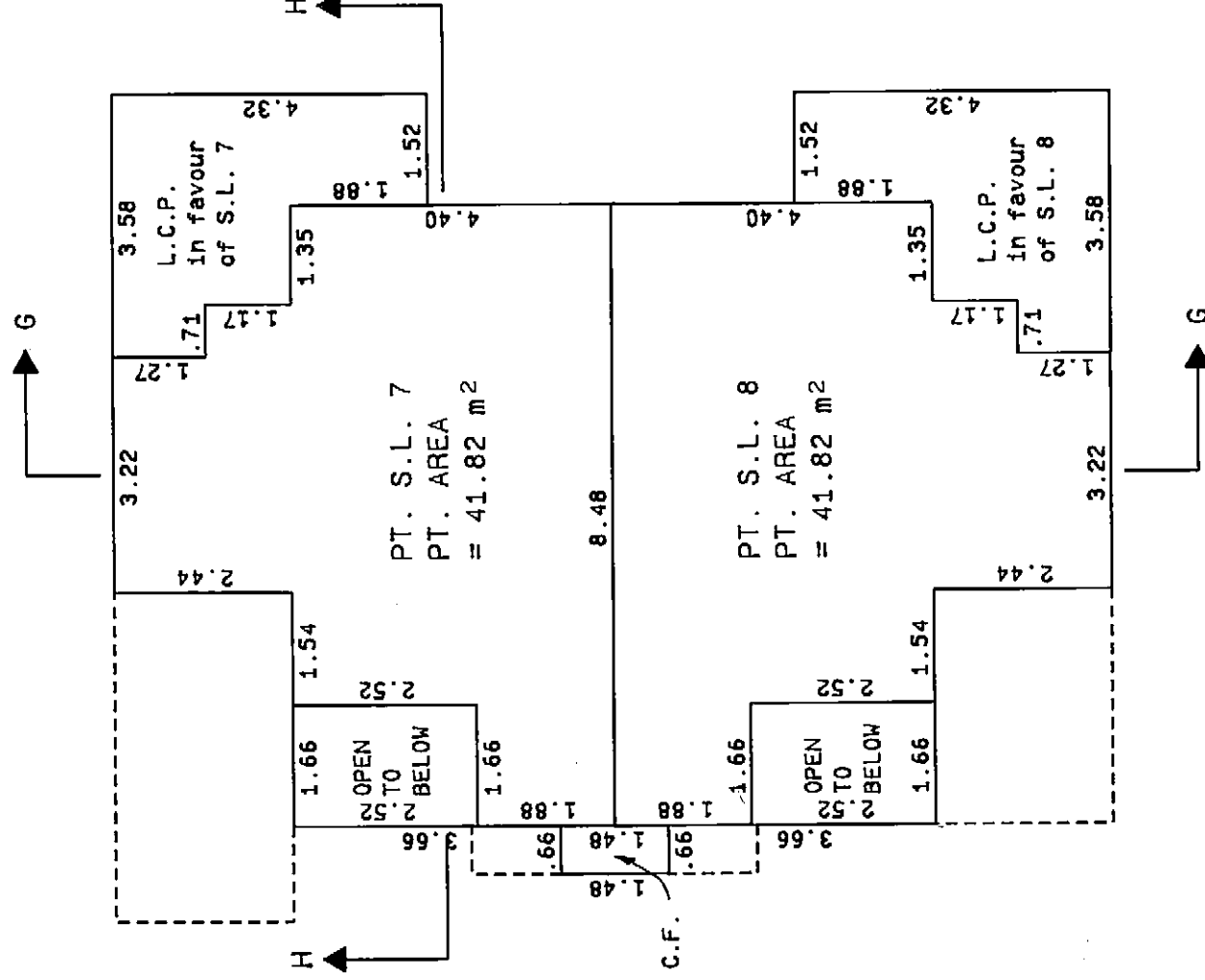
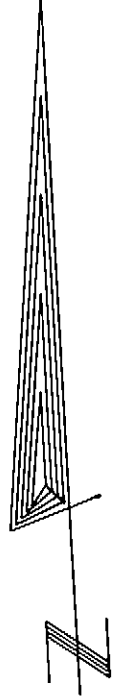

PLAN OF SECOND FLOOR

NOTE:
 S.L. DENOTES STRATA LOT
 C.P. DENOTES COMMON PROPERTY
 L.C.P. DENOTES LIMITED COMMON PROPERTY
 C.F. DENOTES COMMON FACILITY
 PT. DENOTES PART
 B. DENOTES BALCONY
 BALCONIES ARE COMMON PROPERTY AND ARE NOT INCLUDED IN SQUARE METRE (M²) AREAS
 ALL DISTANCES ARE IN METRES.

BB
 December 6 1988
 B.C.L.S.

J88092

SP88324B

SHEET 19 OF 48 SHEETS

PLAN OF STRATA LOTS 7 & 8

STRATA PLAN VR 2325



BUILDING 4

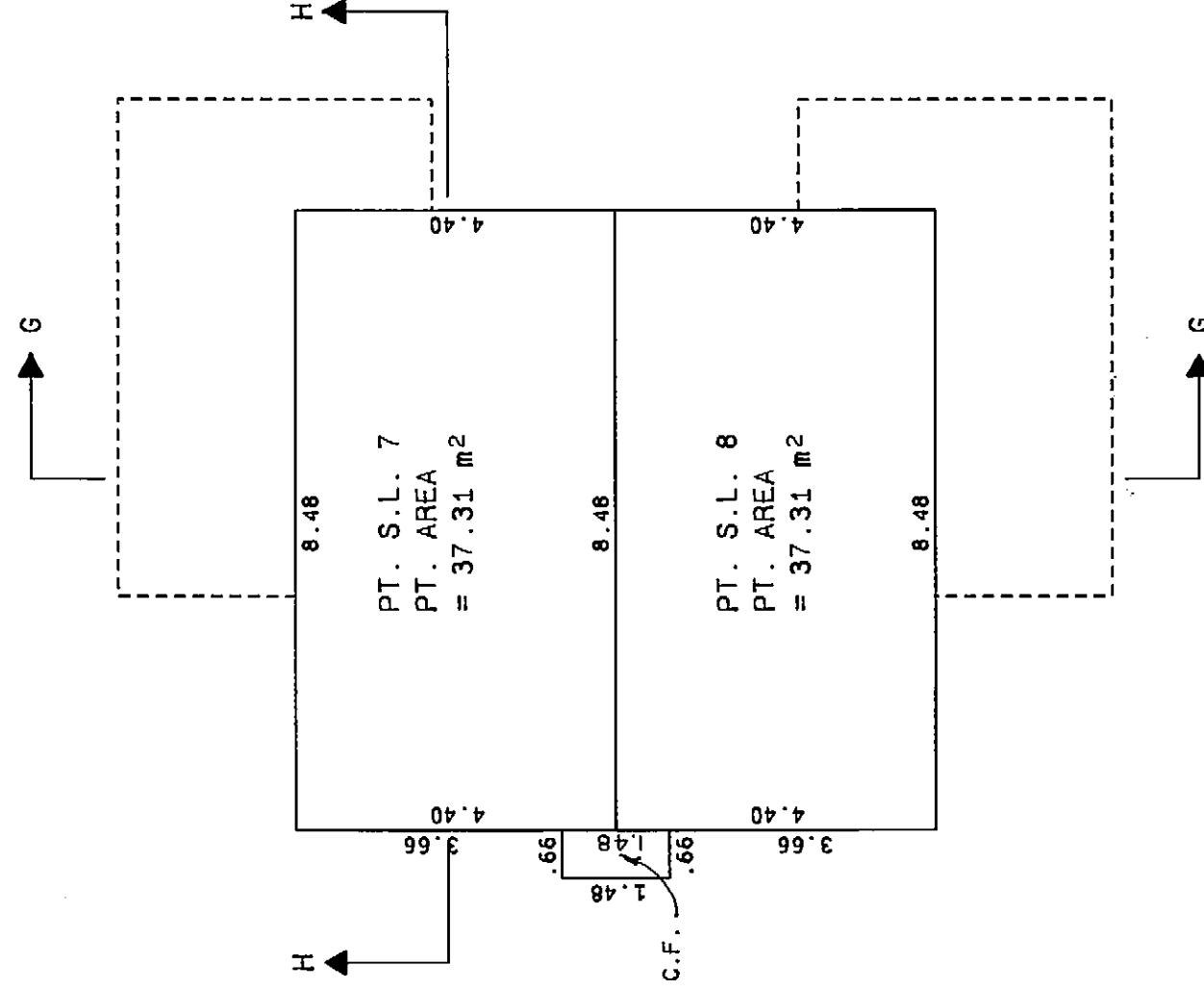
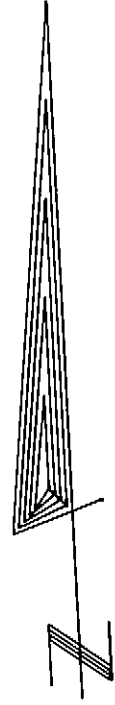

PLAN OF THIRD FLOOR

- NOTE:
- S.L. DENOTES STRATA LOT
 - C.P. DENOTES COMMON PROPERTY
 - L.C.P. DENOTES LIMITED COMMON PROPERTY
 - C.F. DENOTES COMMON FACILITY
 - PT. DENOTES PART
 - B. DENOTES BALCONY
- BALCONIES ARE COMMON PROPERTY AND ARE NOT INCLUDED IN SQUARE METRE (M²) AREAS
ALL DISTANCES ARE IN METRES.

BP
December 6 1988
B.C.L.S.

J88092

SP88324B

SHEET 20 OF 48 SHEETS

PLAN OF STRATA LOTS 9 & 10

STRATA PLAN VR 2325

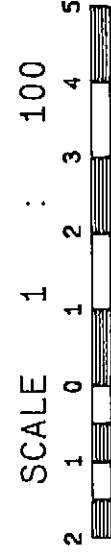

BUILDING 5

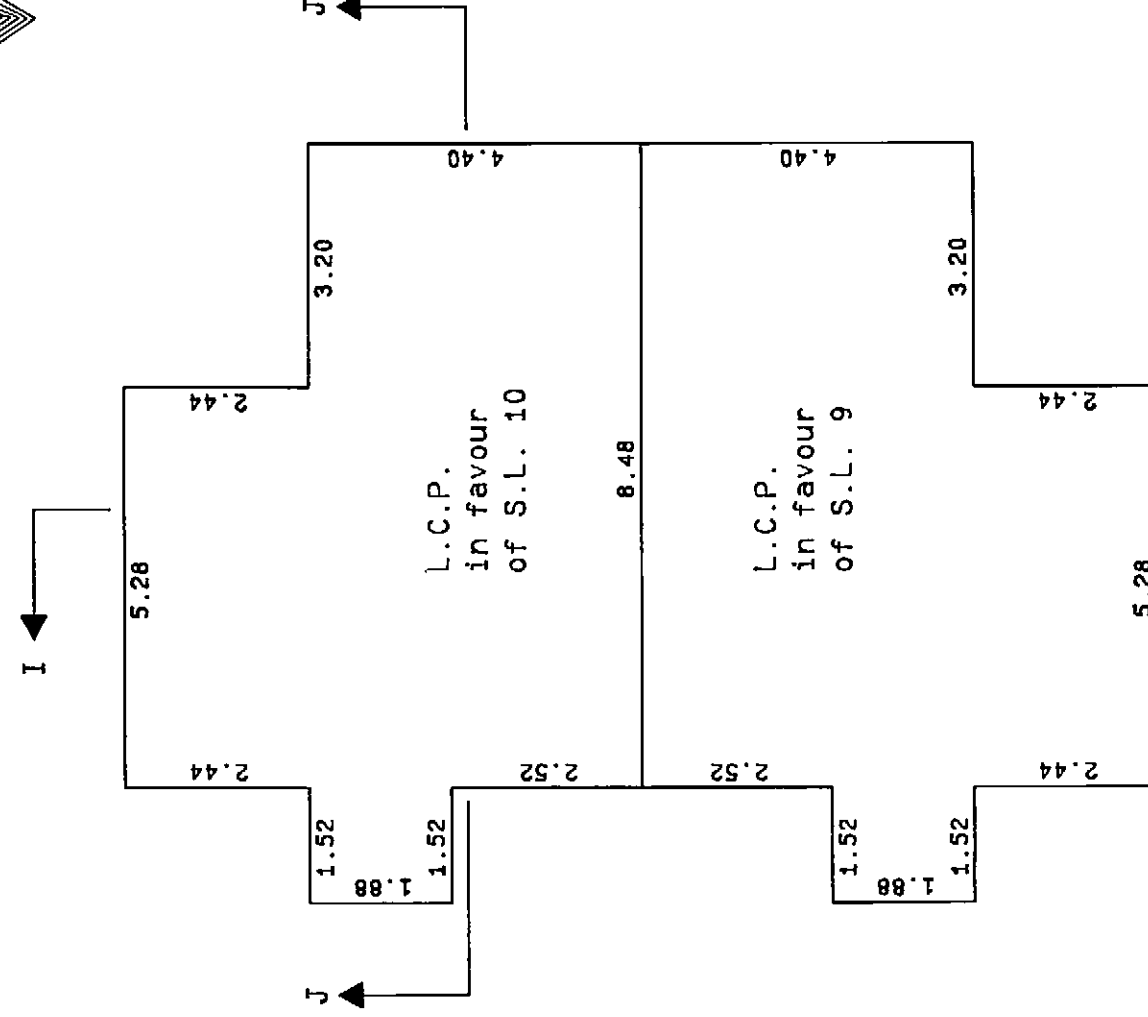
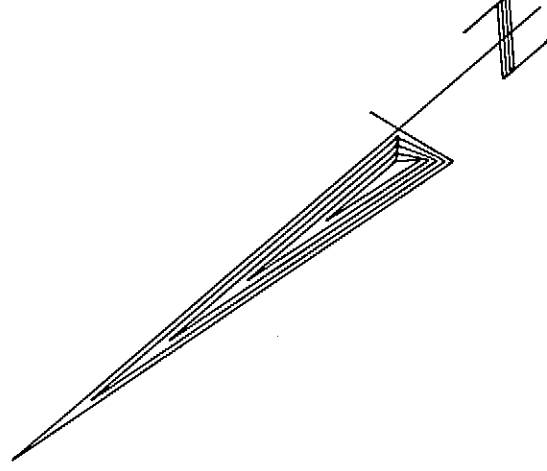

PLAN OF CRAWL SPACE

NOTE:
 S.L. DENOTES STRATA LOT
 C.P. DENOTES COMMON PROPERTY
 L.C.P. DENOTES LIMITED COMMON PROPERTY
 C.F. DENOTES COMMON FACILITY
 PT. DENOTES PART
 B. DENOTES BALCONY
 BALCONIES ARE COMMON PROPERTY AND ARE NOT INCLUDED IN SQUARE METRE (M²) AREAS
 ALL DISTANCES ARE IN METRES.

BB
 December 6 1988
 B.C.L.S.

J88092

SP88324B

SHEET 21 OF 48 SHEETS

PLAN OF STRATA LOTS 9 & 10

STRATA PLAN VR 2325

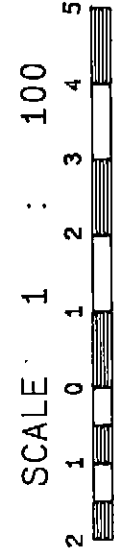

BUILDING 5

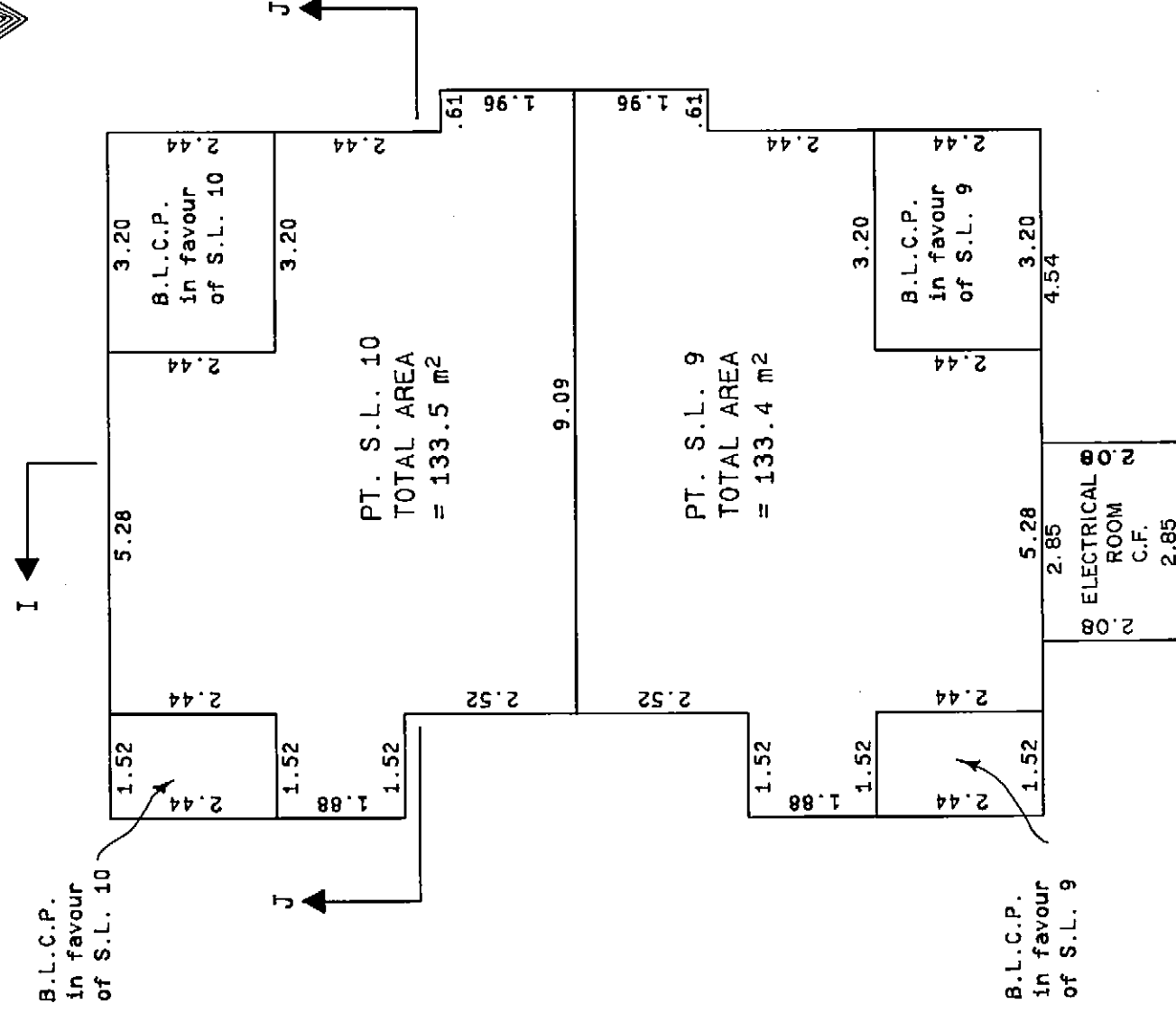
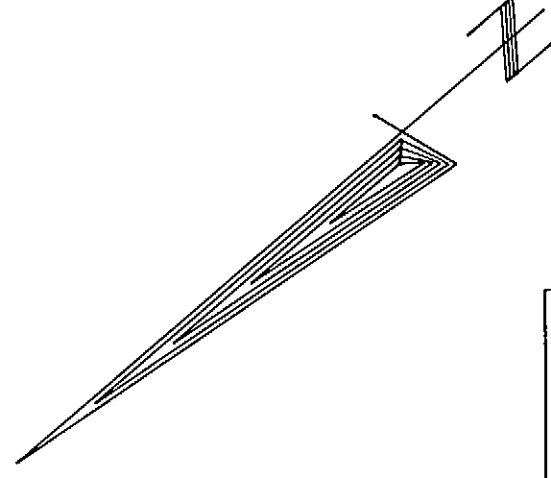

PLAN OF GROUND FLOOR

NOTE:
 S.L. DENOTES STRATA LOT
 C.P. DENOTES COMMON PROPERTY
 L.C.P. DENOTES LIMITED COMMON PROPERTY
 C.F. DENOTES COMMON FACILITY
 PT. DENOTES PART
 B. DENOTES BALCONY
 BALCONIES ARE COMMON PROPERTY AND ARE NOT INCLUDED IN SQUARE METRE (M²) AREAS
 ALL DISTANCES ARE IN METRES.

SP
 December 6 1988
 B.C.L.S.

J88092

SP88324B

SHEET 22 OF 48 SHEETS

PLAN OF STRATA LOTS 9 & 10

STRATA PLAN VR 2325

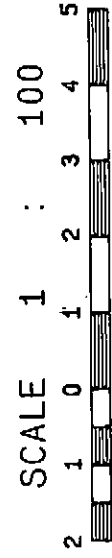

BUILDING 5

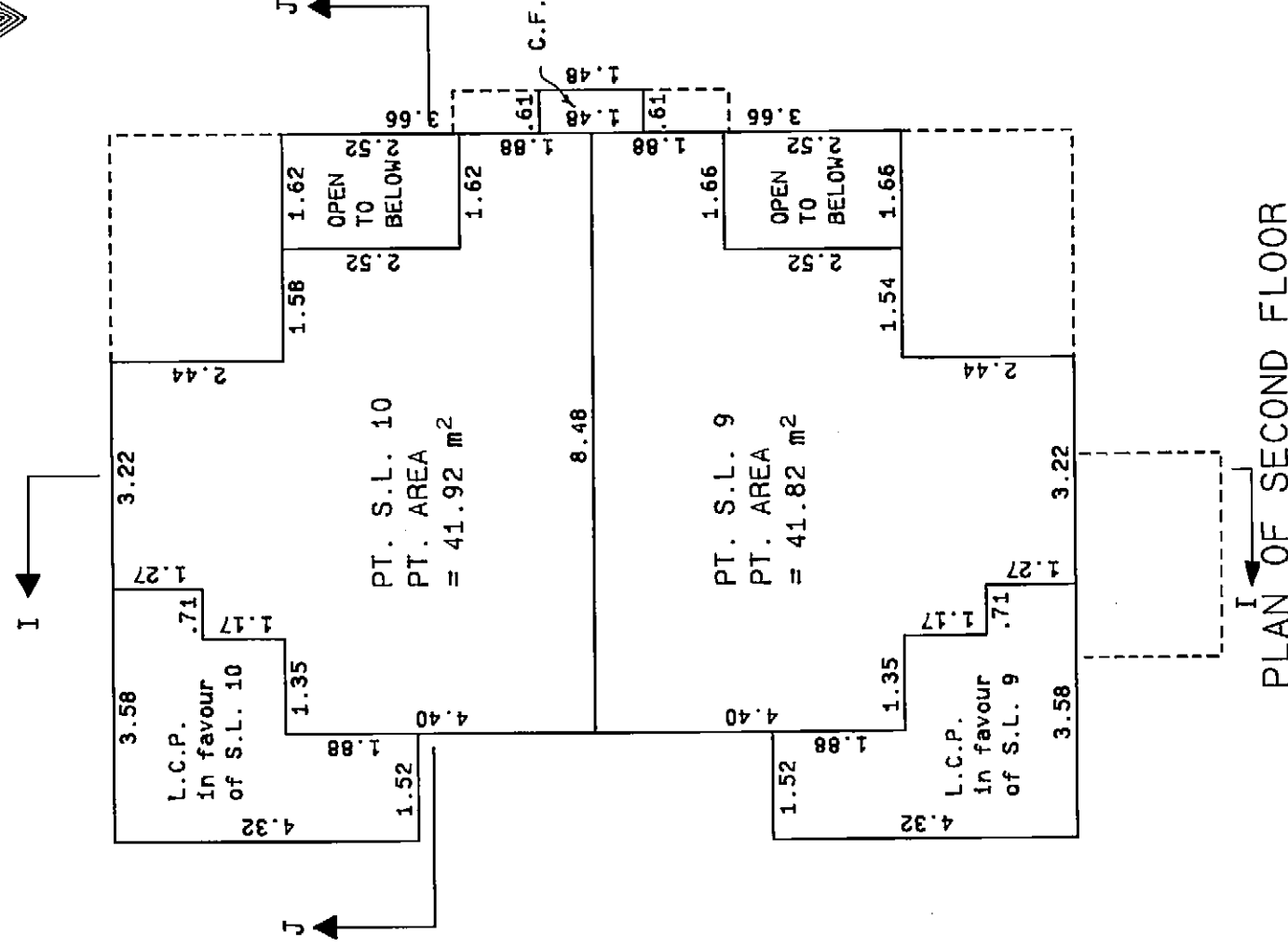
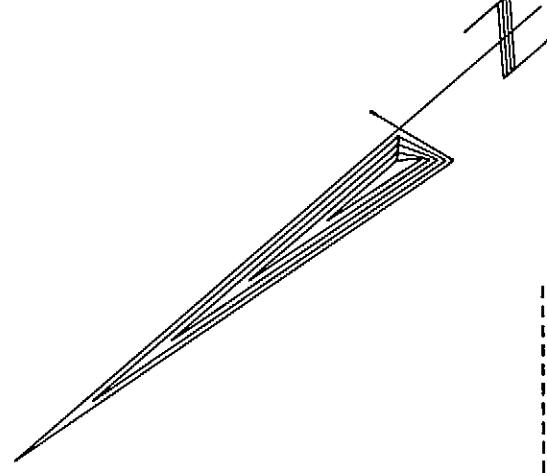

NOTE:
 S.L. DENOTES STRATA LOT
 C.P. DENOTES COMMON PROPERTY
 L.C.P. DENOTES LIMITED COMMON PROPERTY
 C.F. DENOTES COMMON FACILITY
 PT. DENOTES PART
 B. DENOTES BALCONY
 BALCONIES ARE COMMON PROPERTY AND ARE NOT INCLUDED IN SQUARE METRE (M²) AREAS
 ALL DISTANCES ARE IN METRES.

BB
 December 6 1988
 B.C.L.S.

J88092

SP88324B

PLAN OF STRATA LOTS 9 & 10

SHEET 23 OF 48 SHEETS

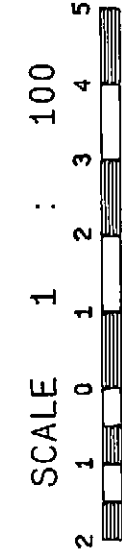

STRATA PLAN VR 2325

BUILDING 5

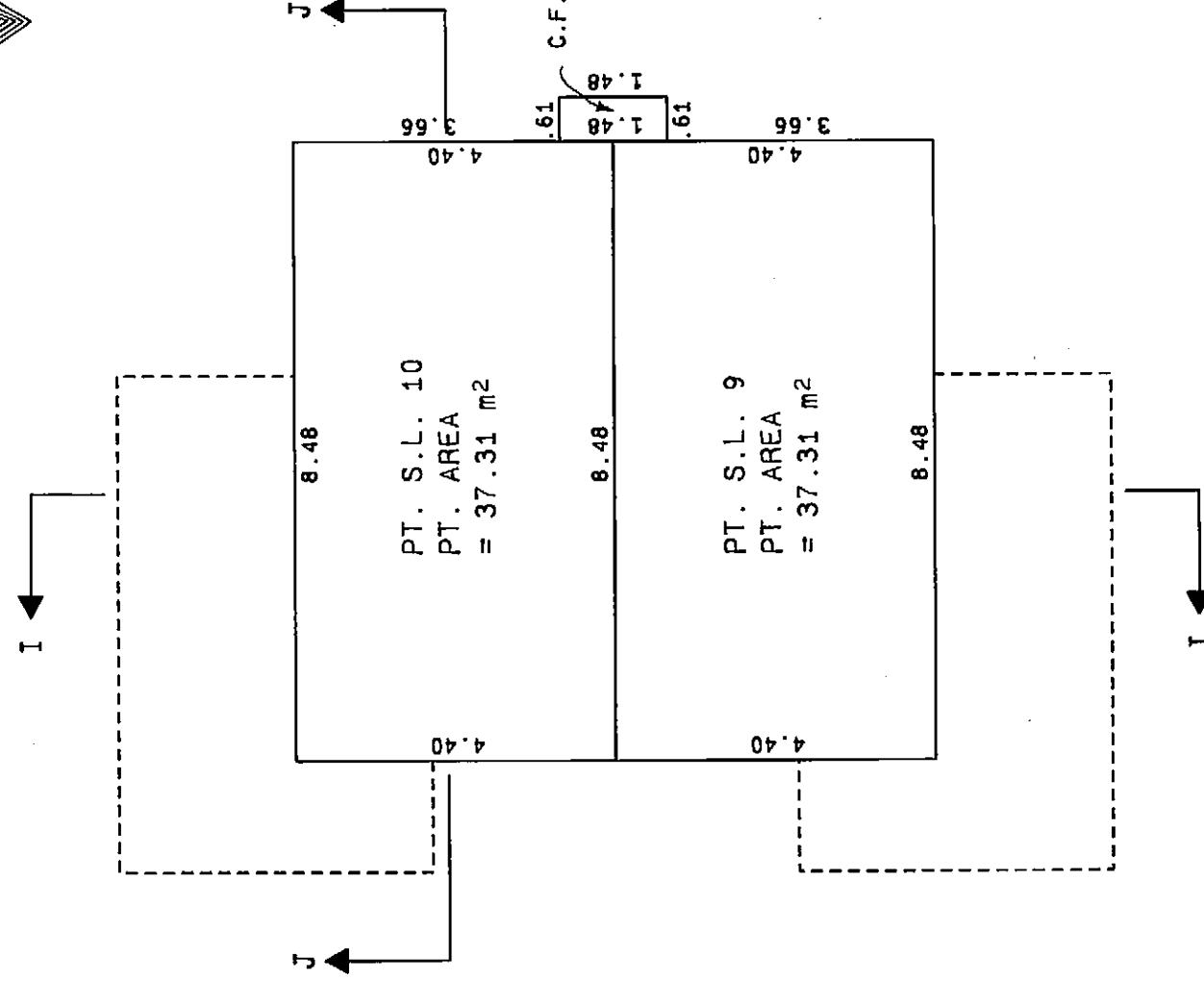
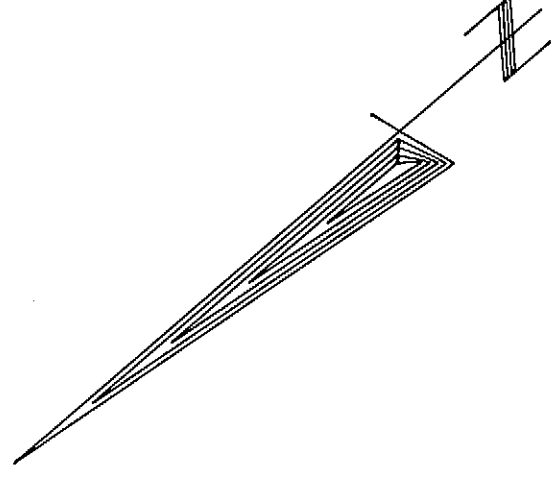

PLAN OF THIRD FLOOR

NOTE:
 S.L. DENOTES STRATA LOT
 C.P. DENOTES COMMON PROPERTY
 L.C.P. DENOTES LIMITED COMMON PROPERTY
 C.F. DENOTES COMMON FACILITY
 PT. DENOTES PART
 B. DENOTES BALCONY
 BALCONIES ARE COMMON PROPERTY AND ARE NOT INCLUDED IN SQUARE METRE (M²) AREAS
 ALL DISTANCES ARE IN METRES.

BB
 ----- B.C.L.S.
December 6 ----- 1988

J88092

SP88324B

SHEET 24 OF 48 SHEETS

PLAN OF STRATA LOTS 11 & 12

STRATA PLAN VR 2325

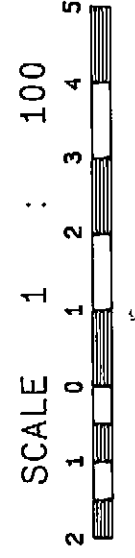

BUILDING 6

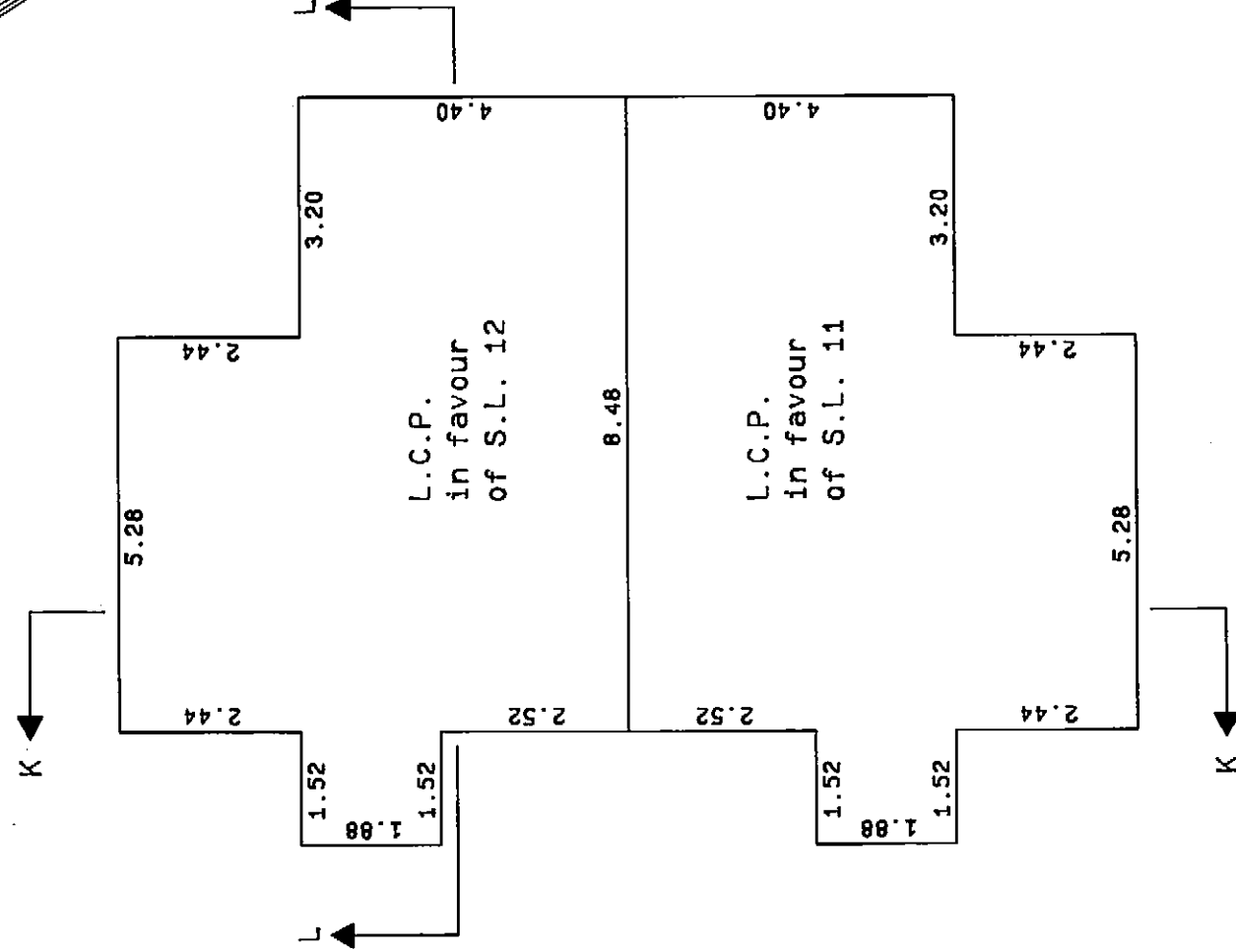
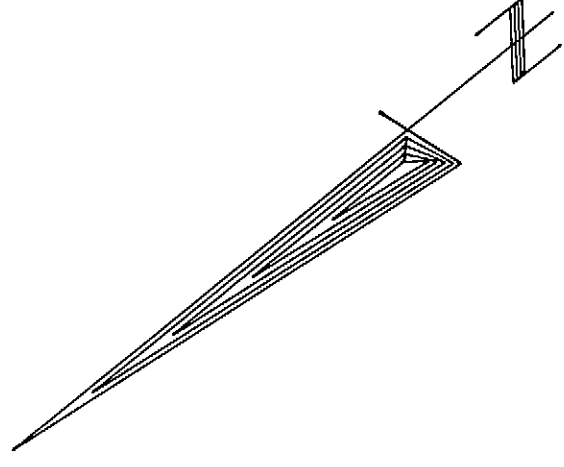

PLAN OF CRAWL SPACE

NOTE:
 S.L. DENOTES STRATA LOT
 C.P. DENOTES COMMON PROPERTY
 L.C.P. DENOTES LIMITED COMMON PROPERTY
 C.F. DENOTES COMMON FACILITY
 PT. DENOTES COMMON PART
 B. DENOTES BALCONY
 BALCONIES ARE COMMON PROPERTY AND ARE NOT INCLUDED IN SQUARE METRE (M) AREAS
 ALL DISTANCES ARE IN METRES.

SP
 December 6 1988
 B.C.L.S.

J88092

SP88324B

PLAN OF STRATA LOTS 11 & 12

SHEET 25 OF 48 SHEETS

STRATA PLAN VR 2325

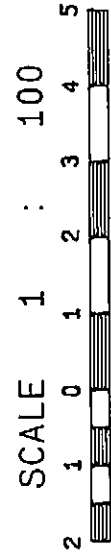

BUILDING 6

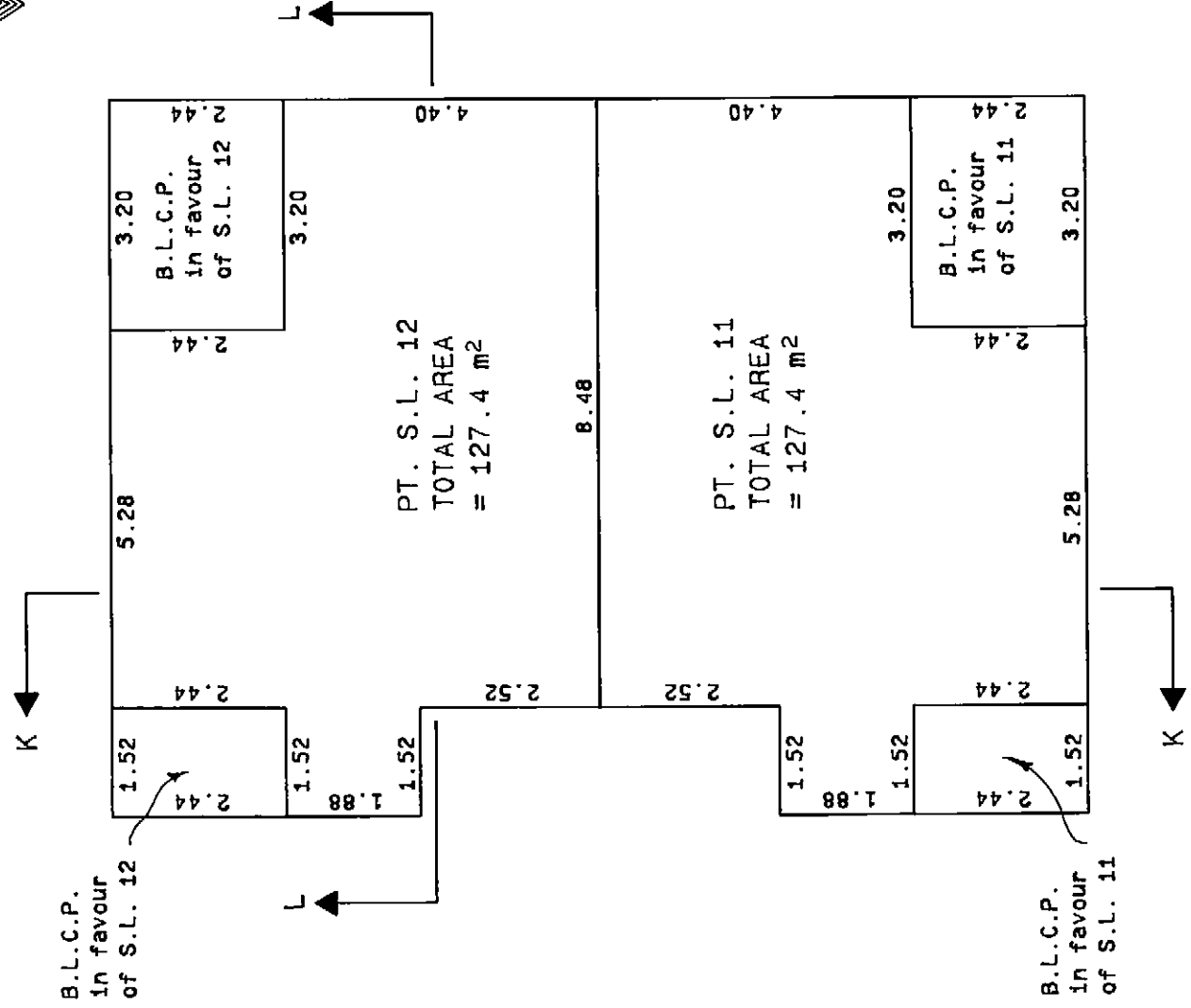
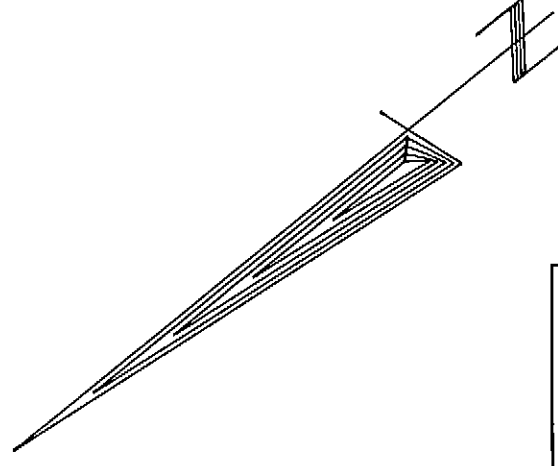

PLAN OF GROUND FLOOR

NOTE:
 S.L. DENOTES STRATA LOT
 C.P. DENOTES COMMON PROPERTY
 L.C.P. DENOTES LIMITED COMMON PROPERTY
 C.F. DENOTES COMMON FACILITY
 PT. DENOTES PART
 B. DENOTES BALCONY
 BALCONIES ARE COMMON PROPERTY AND ARE NOT INCLUDED IN SQUARE METRE (M²) AREAS
 ALL DISTANCES ARE IN METRES.

PP
 December 6 1988
 B.C.L.S.

J88092

SP88324B

SHEET 26 OF 48 SHEETS

PLAN OF STRATA LOTS 11 & 12

STRATA PLAN VR 2325

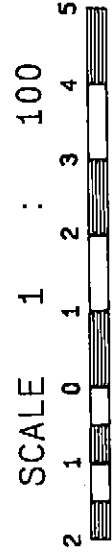

BUILDING 6

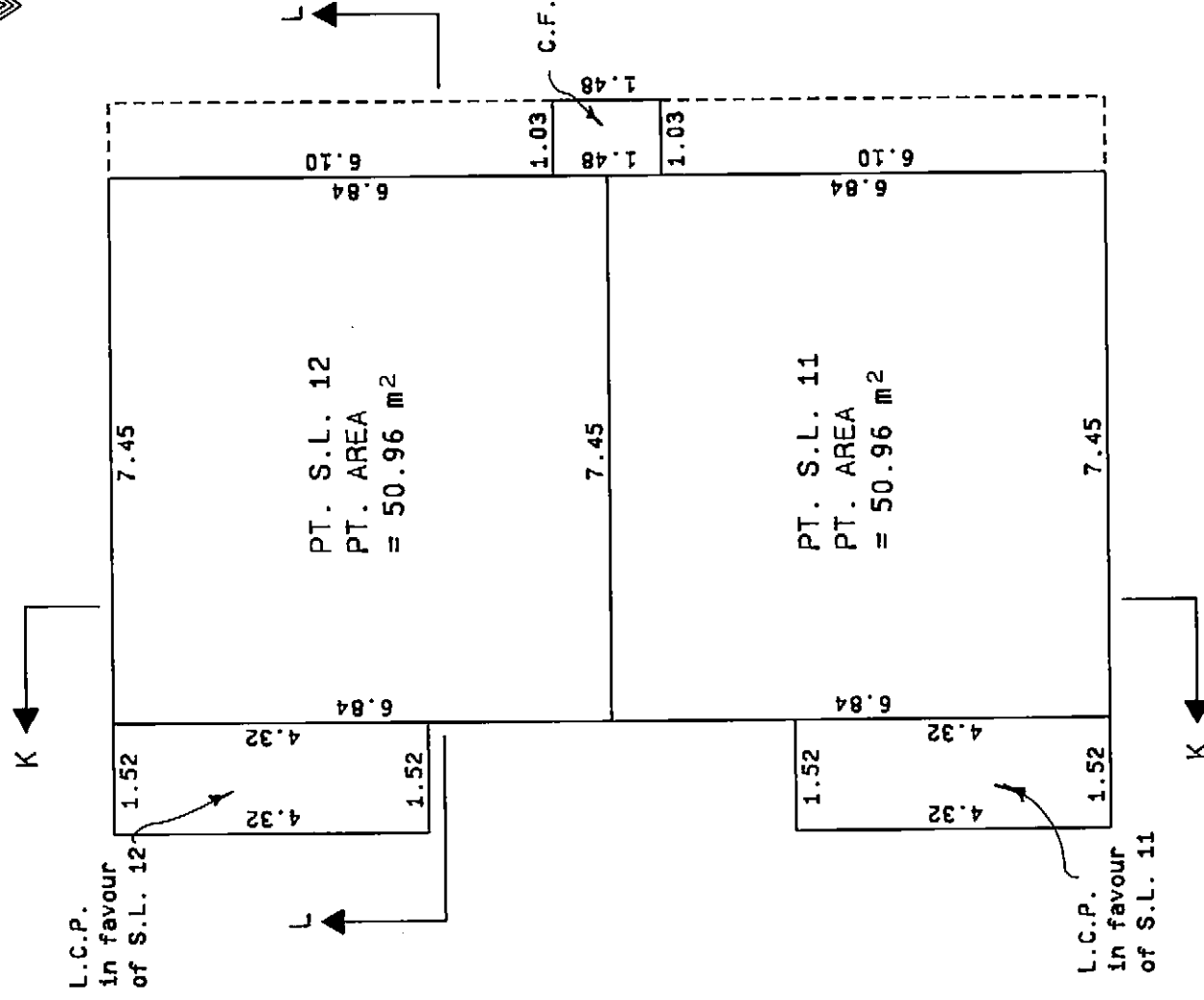
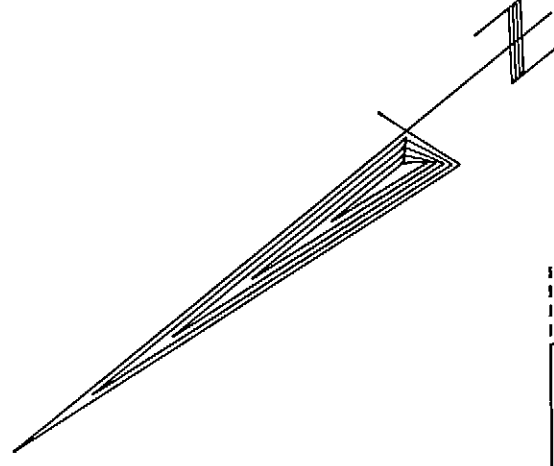

PLAN OF SECOND FLOOR

- NOTE:
- S.L. DENOTES STRATA LOT
 - C.P. DENOTES COMMON PROPERTY
 - L.C.P. DENOTES LIMITED COMMON PROPERTY
 - C.F. DENOTES COMMON FACILITY
 - PT. DENOTES PART
 - B. DENOTES BALCONY
 - BALCONIES ARE COMMON PROPERTY AND ARE NOT INCLUDED IN SQUARE METRE (M²) AREAS
 - ALL DISTANCES ARE IN METRES.

FP

 December 6

 B.C.L.S. 1988

J88092

SP88324B

SHEET 27 OF 48 SHEETS

PLAN OF STRATA LOTS 11 & 12

STRATA PLAN VR 2325

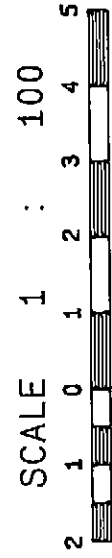

BUILDING 6

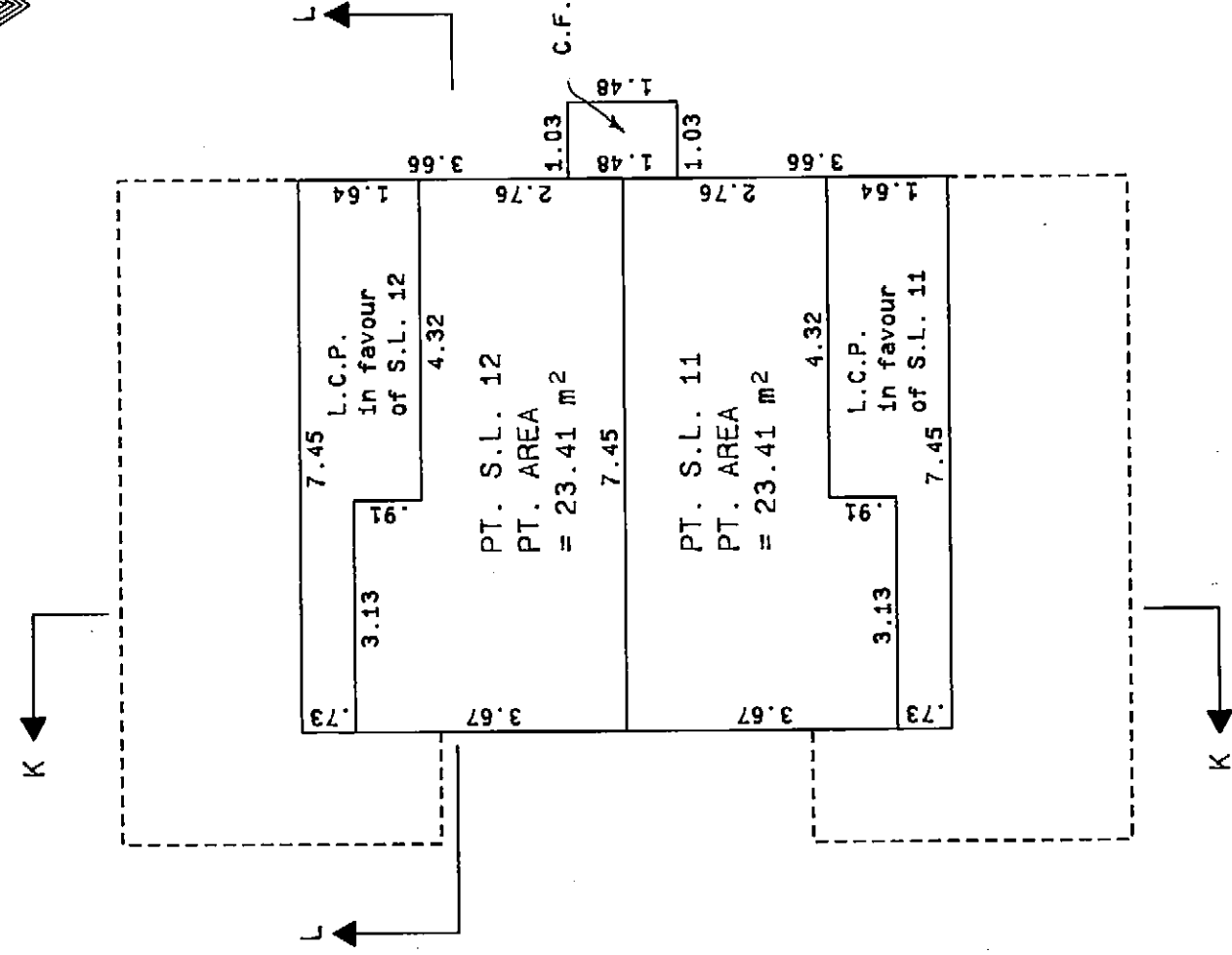
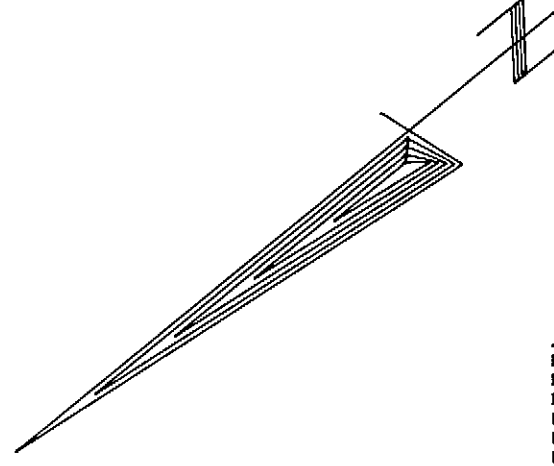

PLAN OF THIRD FLOOR

NOTE:
 S.L. DENOTES STRATA LOT
 C.P. DENOTES COMMON PROPERTY
 L.C.P. DENOTES LIMITED COMMON PROPERTY
 C.F. DENOTES COMMON FACILITY
 PT. DENOTES PART
 B. DENOTES BALCONY
 BALCONIES ARE COMMON PROPERTY AND ARE
 NOT INCLUDED IN SQUARE METRE (M²) AREAS
 ALL DISTANCES ARE IN METRES.

BB
 December 6 1988
 B.C.L.S.

J88092

SP88324B

PLAN OF STRATA LOT 13

SHEET 28 OF 48 SHEETS

STRATA PLAN VR 2325

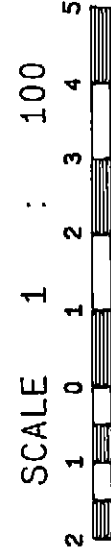

BUILDING 7

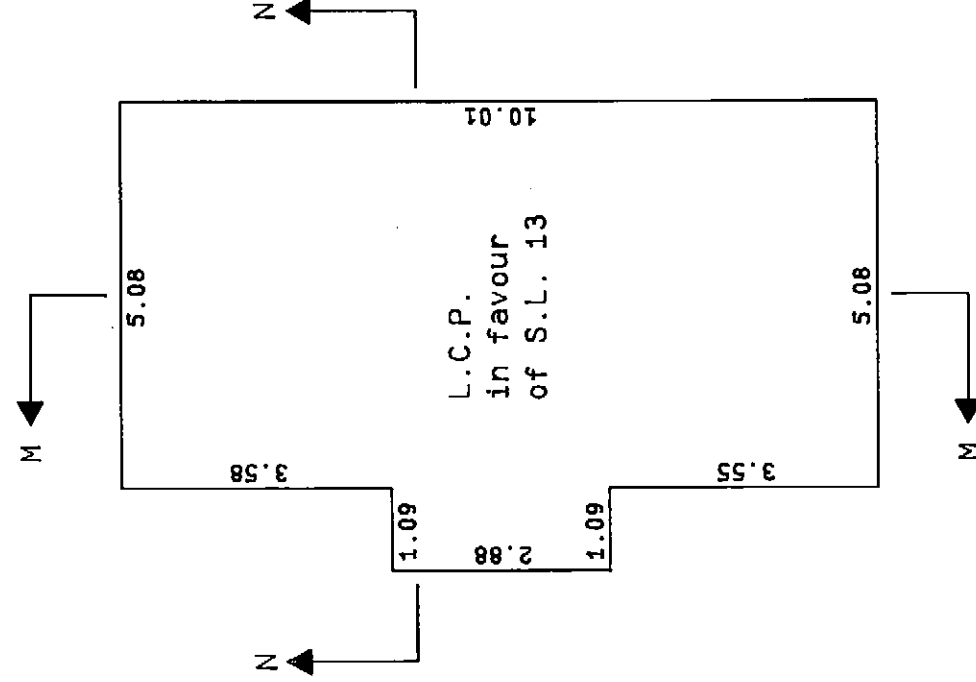
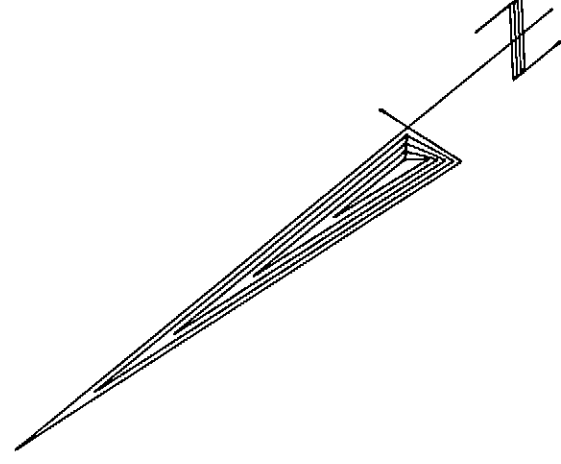

L.C.P. in favour of S.L. 13

PLAN OF CRAWL SPACE

NOTE:
 S.L. DENOTES STRATA LOT
 C.P. DENOTES COMMON PROPERTY
 L.C.P. DENOTES LIMITED COMMON PROPERTY
 C.F. DENOTES COMMON FACILITY
 PT. DENOTES PART
 B. DENOTES BALCONY
 BALCONIES ARE COMMON PROPERTY AND ARE NOT INCLUDED IN SQUARE METRE (M²) AREAS
 ALL DISTANCES ARE IN METRES.

BB
 December 6 1988
 B.C.L.S.

J88092

SP88324B

SHEET 29 OF 48 SHEETS

PLAN OF STRATA LOT 13

STRATA PLAN VR 2325

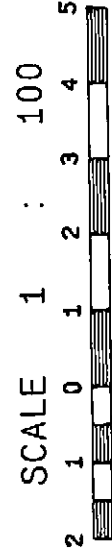

BUILDING 7

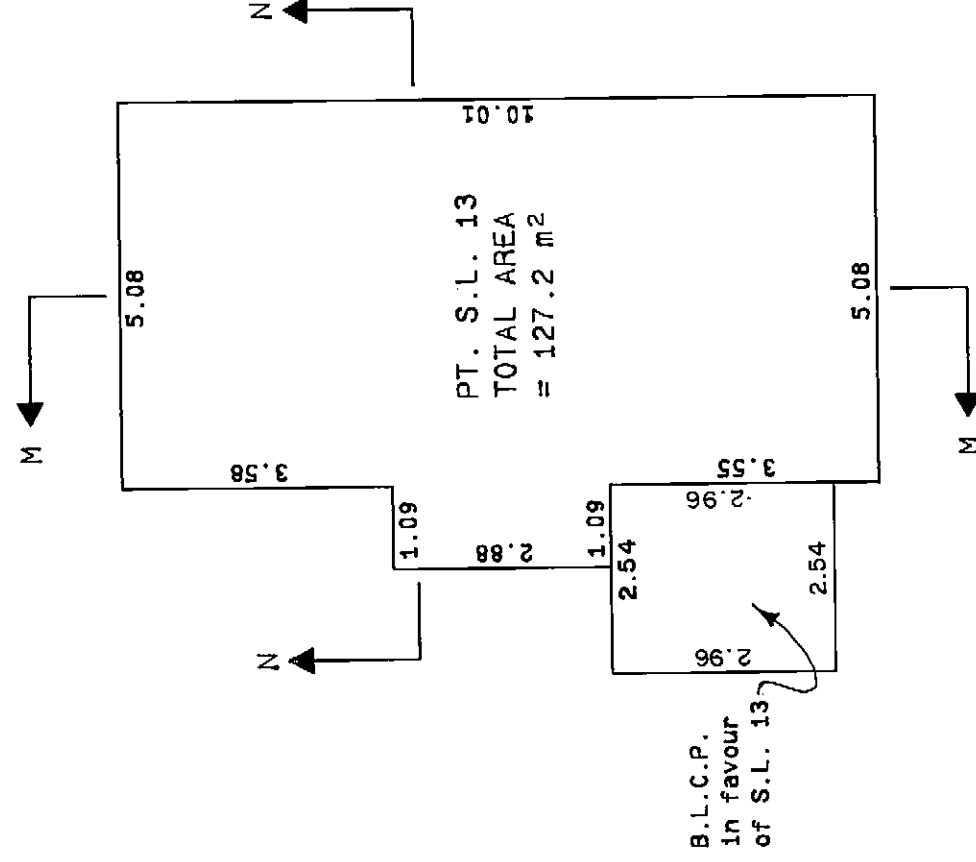
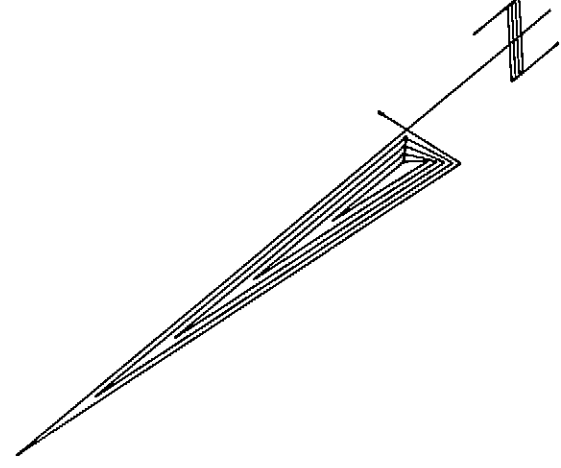

PLAN OF GROUND FLOOR

NOTE:
 S.L. DENOTES STRATA LOT
 C.P. DENOTES COMMON PROPERTY
 L.C.P. DENOTES LIMITED COMMON PROPERTY
 C.F. DENOTES COMMON FACILITY
 PT. DENOTES PART
 B. DENOTES BALCONY
 BALCONIES ARE COMMON PROPERTY AND ARE NOT INCLUDED IN SQUARE METRE (M²) AREAS
 ALL DISTANCES ARE IN METRES.

BB
 December 6 1988
 B.C.L.S.

J88092

SP88324B

PLAN OF STRATA LOT 13

SHEET 30 OF 48 SHEETS

STRATA PLAN VR 2325

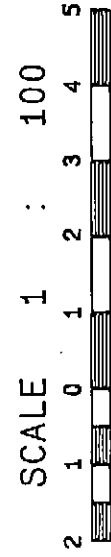

BUILDING 7

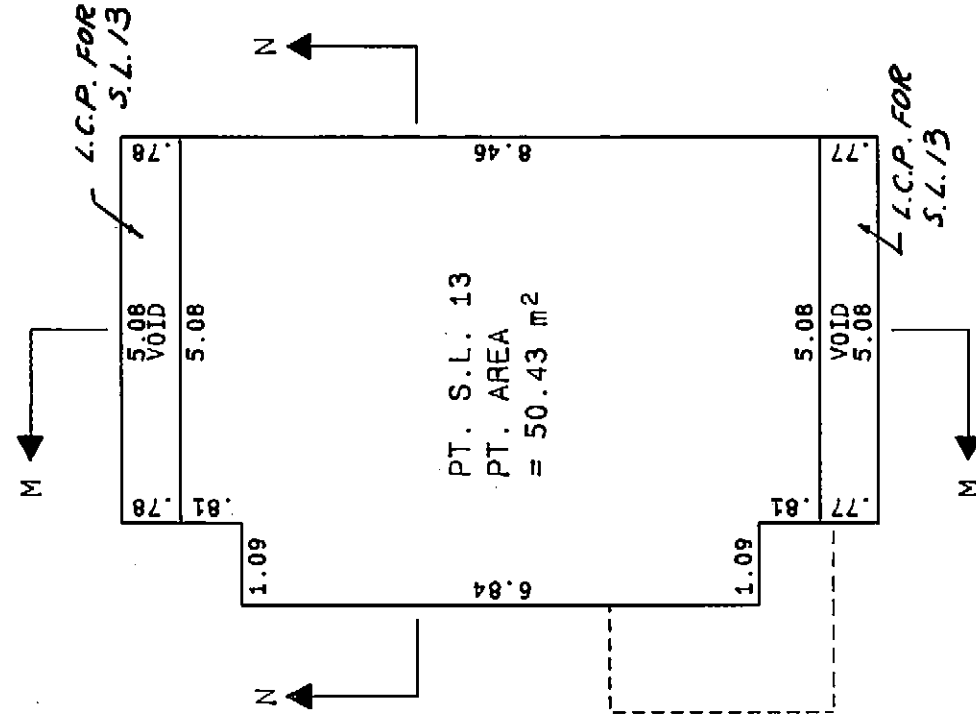
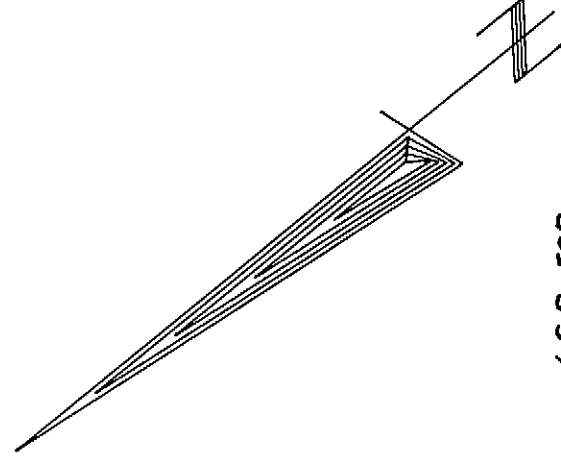

PLAN OF SECOND FLOOR

NOTE:
 S.L. DENOTES STRATA LOT
 C.P. DENOTES COMMON PROPERTY
 L.C.P. DENOTES LIMITED COMMON PROPERTY
 C.F. DENOTES COMMON FACILITY
 PT. DENOTES PART
 B. DENOTES BALCONY
 BALCONIES ARE COMMON PROPERTY AND ARE NOT INCLUDED IN SQUARE METRE (M²) AREAS
 ALL DISTANCES ARE IN METRES.

BB
 December 6 1988
 B.C.L.S.

J88092

SP88324B

SHEET 31 OF 48 SHEETS

PLAN OF STRATA LOT 13

STRATA PLAN VR 2325

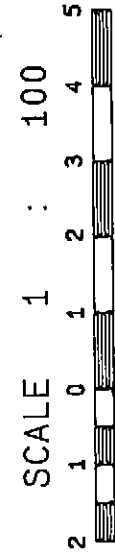

BUILDING 7

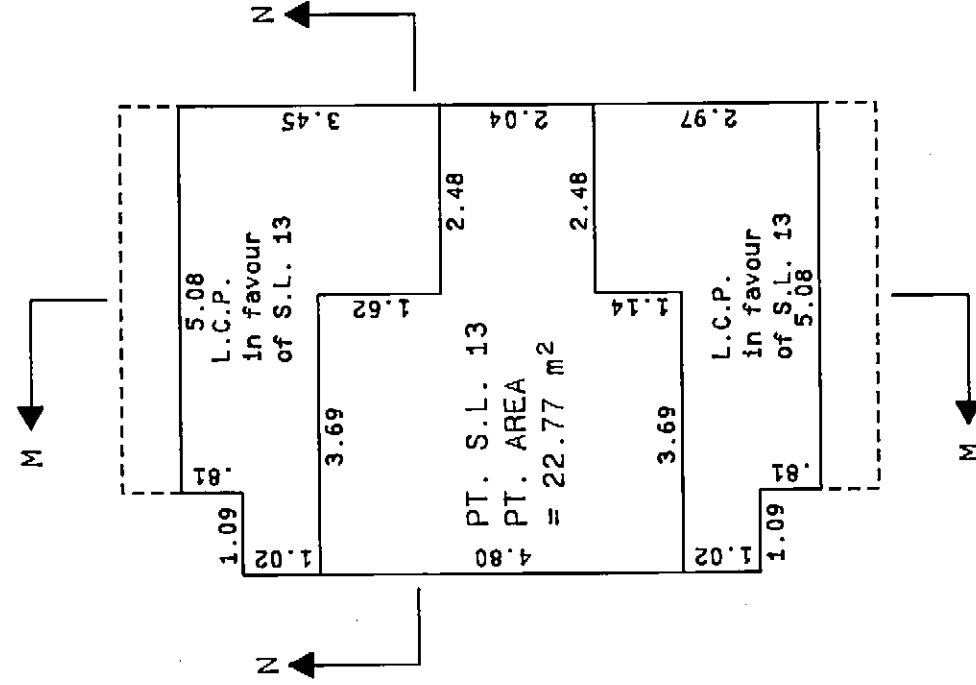
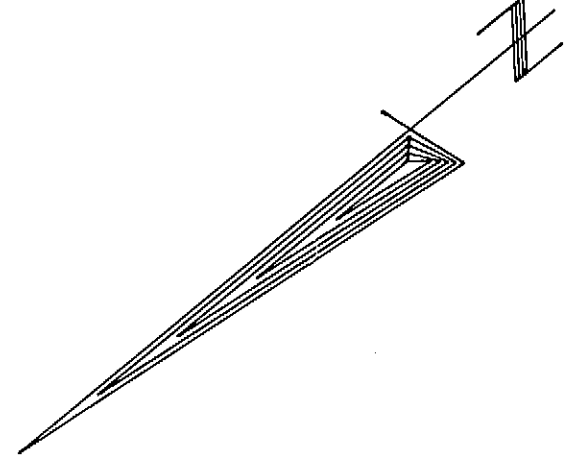

PLAN OF THIRD FLOOR

NOTE:
 S.L. DENOTES STRATA LOT
 C.P. DENOTES COMMON PROPERTY
 L.C.P. DENOTES LIMITED COMMON PROPERTY
 C.F. DENOTES COMMON FACILITY
 PT. DENOTES PART
 B. DENOTES BALCONY
 BALCONIES ARE COMMON PROPERTY AND ARE NOT INCLUDED IN SQUARE METRE (M²) AREAS
 ALL DISTANCES ARE IN METRES.

PP
 _____ B.C.L.S.
 December 6 1988

J88092

SP88324B

SHEET 32 OF 48 SHEETS

CROSS - SECTIONS

STRATA PLAN VR 2325

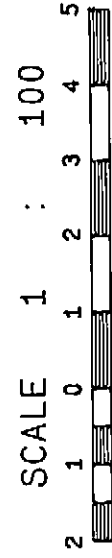

BUILDING 1

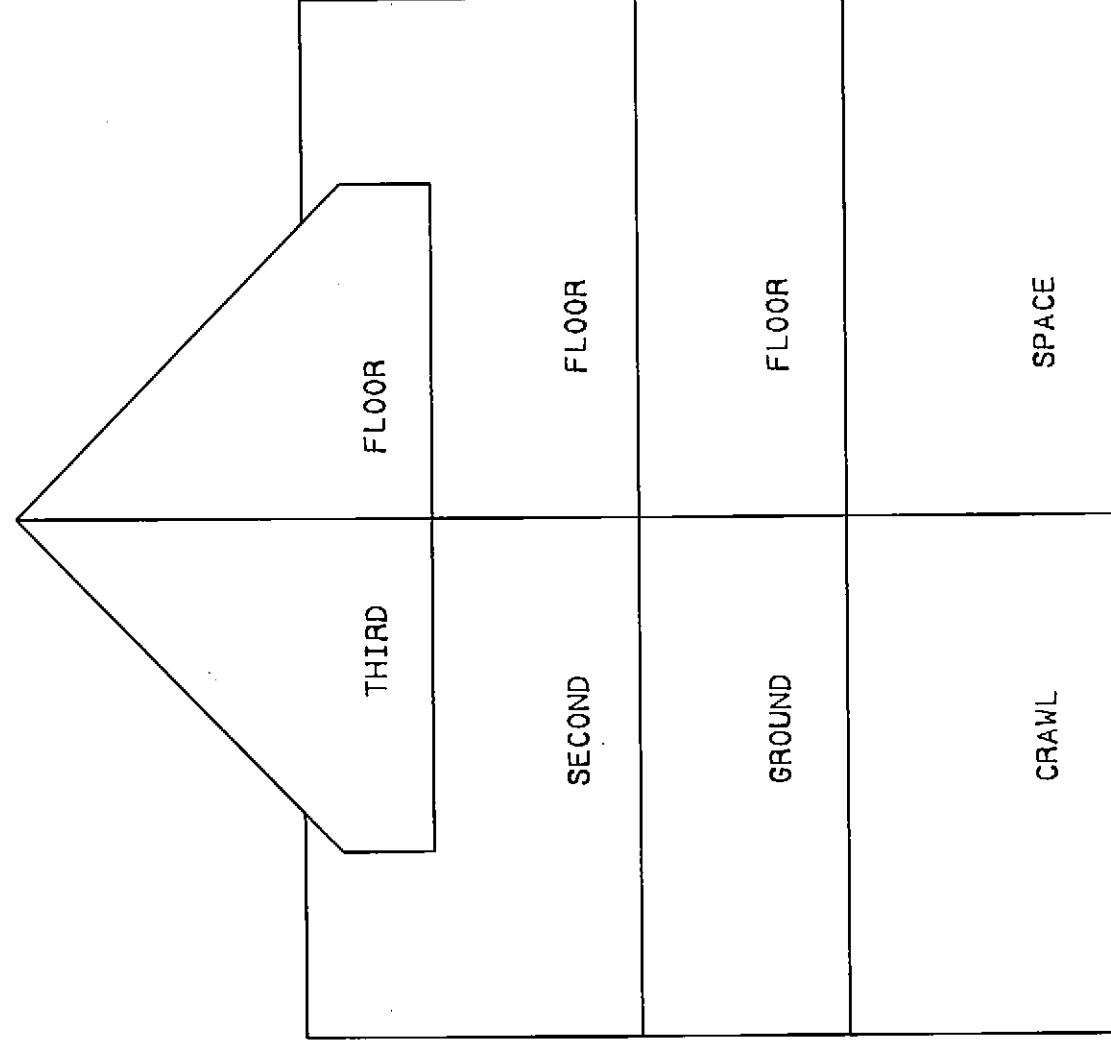

S.L. 1 S.L. 2

CROSS-SECTION 'A-A'

NOTE:
 S.L. DENOTES STRATA LOT
 C.P. DENOTES COMMON PROPERTY
 L.C.P. DENOTES LIMITED COMMON PROPERTY
 C.F. DENOTES COMMON FACILITY
 PT. DENOTES PART
 B. DENOTES BALCONY
 BALCONIES ARE COMMON PROPERTY AND ARE NOT INCLUDED IN SQUARE METRE (M²) AREAS
 ALL DISTANCES ARE IN METRES.

RP
 ----- B.C.L.S.
December 6 1988

J88092

SP88324B

SHEET 33 OF 48 SHEETS

CROSS - SECTIONS

STRATA PLAN VR 2325



BUILDING 1

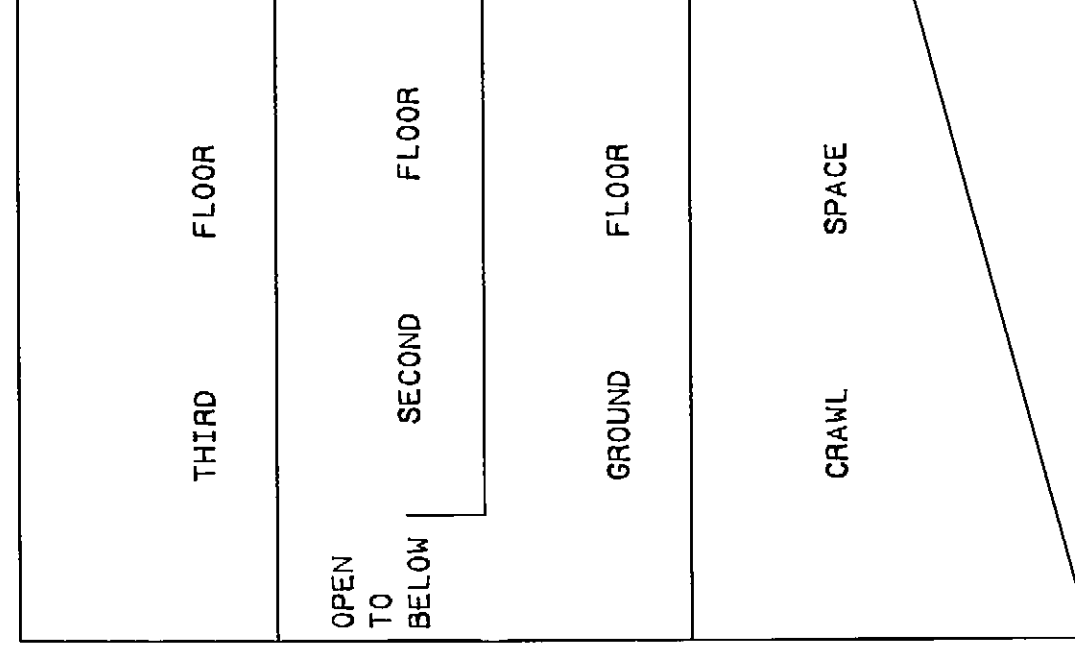

S.L. 1

CROSS-SECTION 'B-B'

NOTE:

- S.L. DENOTES STRATA LOT
 - C.P. DENOTES COMMON PROPERTY
 - L.C.P. DENOTES LIMITED COMMON PROPERTY
 - C.F. DENOTES COMMON FACILITY
 - PT. DENOTES PART
 - B. DENOTES BALCONY
- BALCONIES ARE COMMON PROPERTY AND ARE NOT INCLUDED IN SQUARE METRE (M²) AREAS
ALL DISTANCES ARE IN METRES.

BB
 ----- B.C.L.S.
December 6 ----- 1988

J88092

SP88324B

SHEET 34 OF 48 SHEETS

CROSS - SECTIONS

STRATA PLAN VR 2325

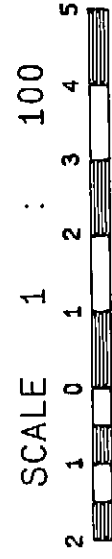

BUILDING 2

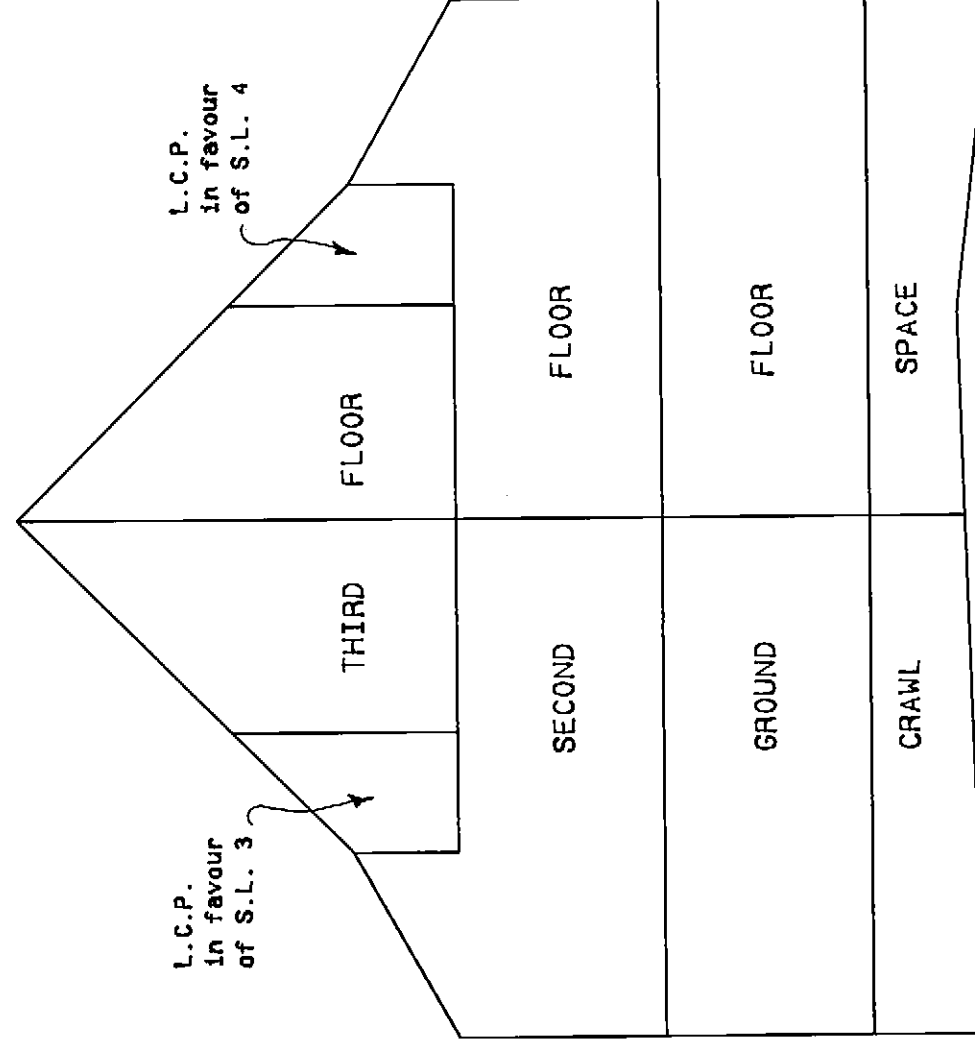

S.L. 3

S.L. 4

CROSS-SECTION 'C-C'

NOTE:
 S.L. DENOTES STRATA LOT
 C.P. DENOTES COMMON PROPERTY
 L.C.P. DENOTES LIMITED COMMON PROPERTY
 C.F. DENOTES COMMON FACILITY
 PT. DENOTES PART
 B. DENOTES BALCONY
 BALCONIES ARE COMMON PROPERTY AND ARE NOT INCLUDED IN SQUARE METRE (M²) AREAS
 ALL DISTANCES ARE IN METRES.

BB
 _____ B.C.L.S.
December 6 1988

J88092

SP88324B

SHEET 35 OF 48 SHEETS

CROSS - SECTIONS

STRATA PLAN VR 2325

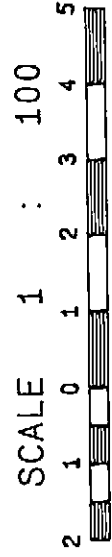

BUILDING 2

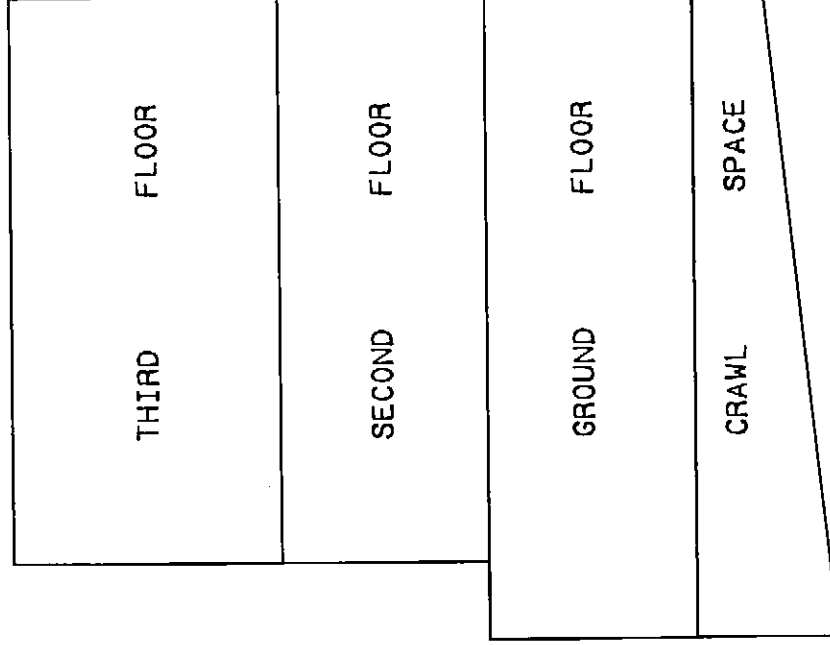

S.L. 3

CROSS-SECTION 'D-D'

NOTE:
 S.L. DENOTES STRATA LOT
 C.P. DENOTES COMMON PROPERTY
 L.C.P. DENOTES LIMITED COMMON PROPERTY
 C.F. DENOTES COMMON FACILITY
 PT. DENOTES PART
 B. DENOTES BALCONY
 BALCONIES ARE COMMON PROPERTY AND ARE NOT INCLUDED IN SQUARE METRE (M²) AREAS
 ALL DISTANCES ARE IN METRES.

BB
 _____ B.C.L.S.
 December 6 1988

J88092

SP88324B

SHEET 36 OF 48 SHEETS

CROSS - SECTIONS

STRATA PLAN VR 2325

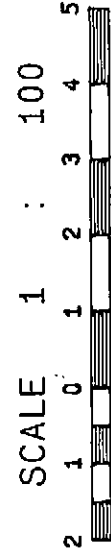

BUILDING 3

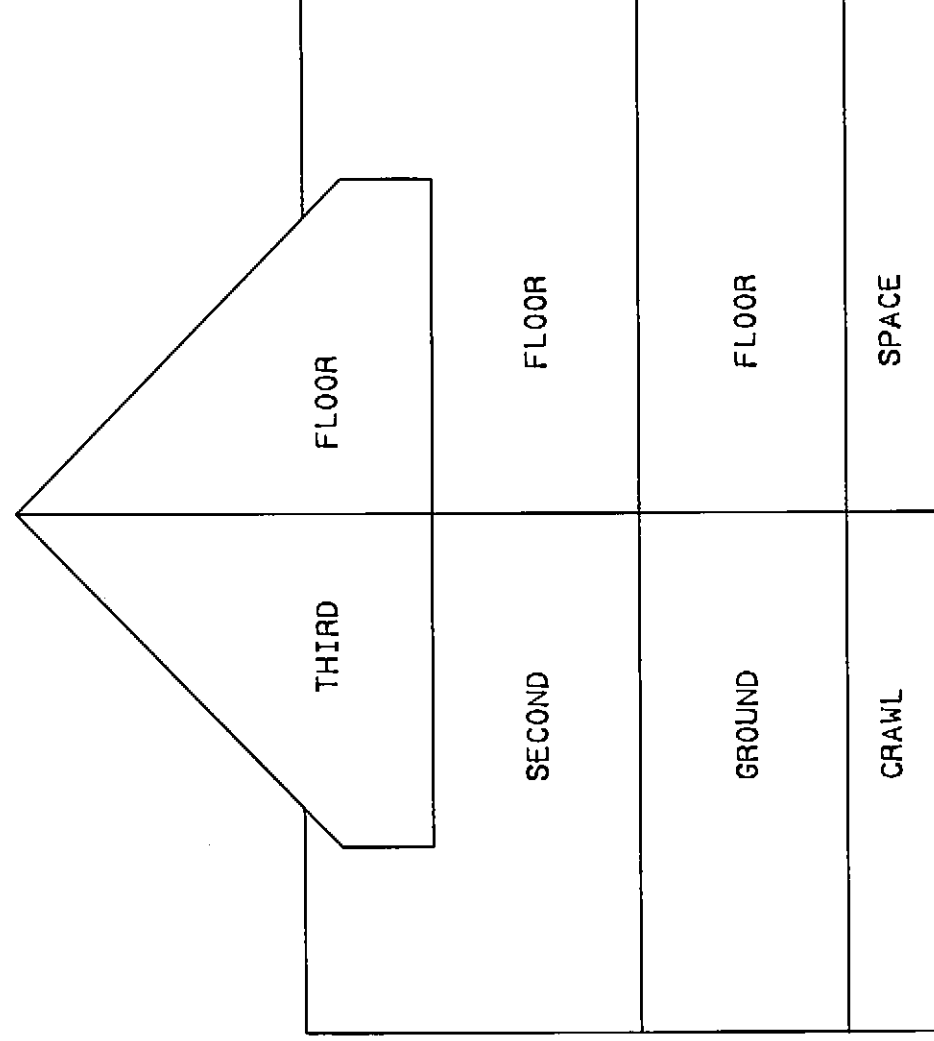

S.L. 5 S.L. 6

CROSS-SECTION 'E-E'

NOTE:

- S.L. DENOTES STRATA LOT
 - C.P. DENOTES COMMON PROPERTY
 - L.C.P. DENOTES LIMITED COMMON PROPERTY
 - C.F. DENOTES COMMON FACILITY
 - PT. DENOTES PART
 - B. DENOTES BALCONY
- BALCONIES ARE COMMON PROPERTY AND ARE NOT INCLUDED IN SQUARE METRE (M²) AREAS
ALL DISTANCES ARE IN METRES.

BB

December 6

 B.C.L.S. 1988

J88092

SP88324B

SHEET 37 OF 48 SHEETS

CROSS - SECTIONS

STRATA PLAN VR 2325

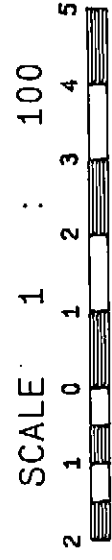

BUILDING 3

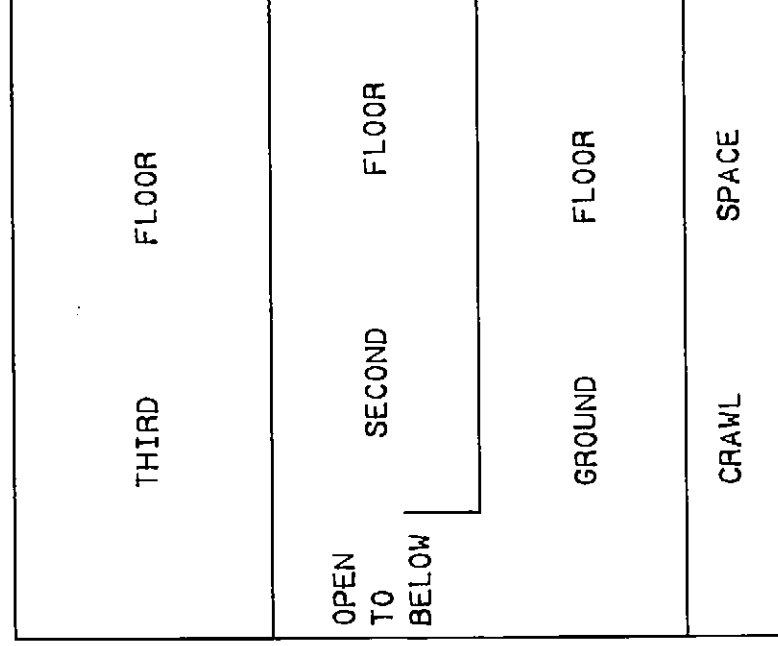

S.L. 5

CROSS-SECTION 'F-F'

NOTE:
 S.L. DENOTES STRATA LOT
 C.P. DENOTES COMMON PROPERTY
 L.C.P. DENOTES LIMITED COMMON PROPERTY
 C.F. DENOTES COMMON FACILITY
 PT. DENOTES PART
 B. DENOTES BALCONY
 BALCONIES ARE COMMON PROPERTY AND ARE NOT INCLUDED IN SQUARE METRE (M²) AREAS
 ALL DISTANCES ARE IN METRES.

BB
 ----- B.C.L.S.
December 6 ----- 1988

J88092

SP88324B

CROSS - SECTIONS

SHEET 38 OF 48 SHEETS

STRATA PLAN VR 2325

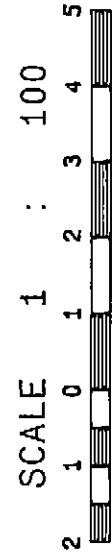

BUILDING 4

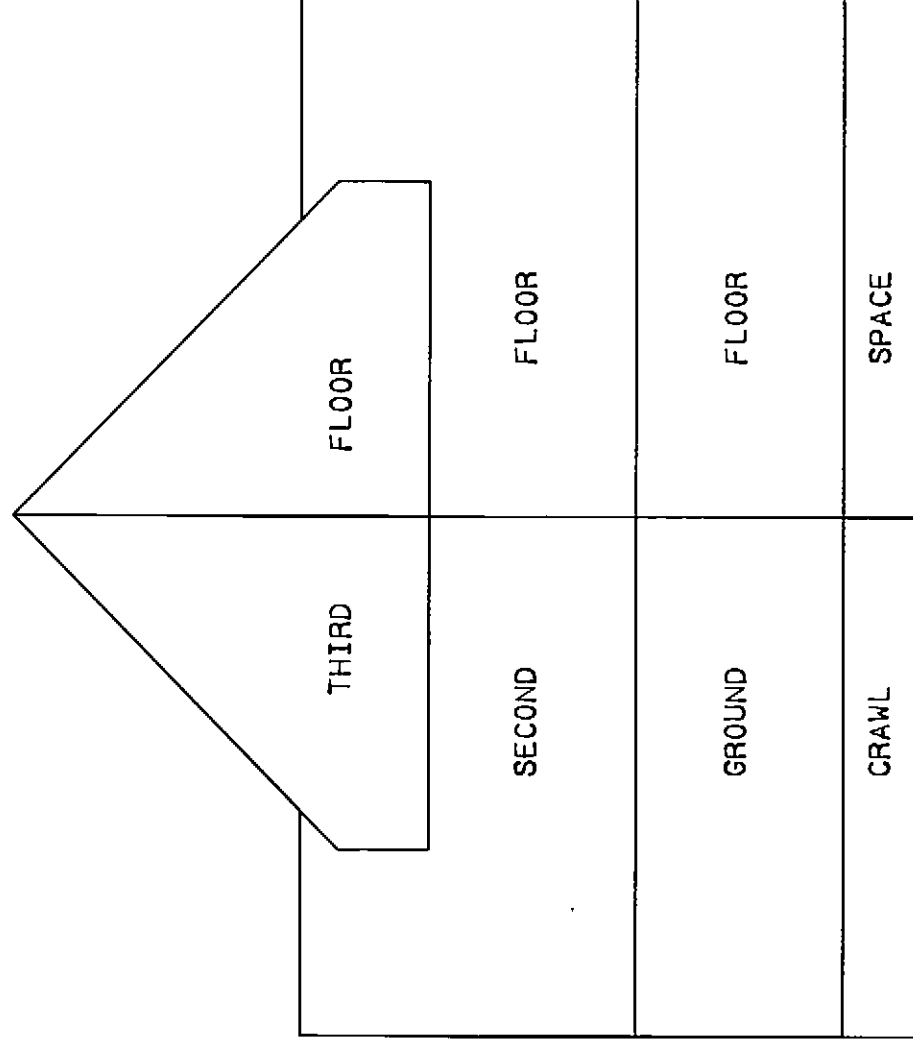

S.L. 7 S.L. 8

CROSS-SECTION 'G-G'

NOTE:
 S.L. DENOTES STRATA LOT
 C.P. DENOTES COMMON PROPERTY
 L.C.P. DENOTES LIMITED COMMON PROPERTY
 C.F. DENOTES COMMON FACILITY
 PT. DENOTES PART
 B. DENOTES BALCONY
 BALCONIES ARE COMMON PROPERTY AND ARE NOT INCLUDED IN SQUARE METRE (M²) AREAS
 ALL DISTANCES ARE IN METRES.

BB
 _____ B.C.L.S.
December 6 1988

J88092

SP88324B

SHEET 39 OF 48 SHEETS

CROSS - SECTIONS

STRATA PLAN VR 2325

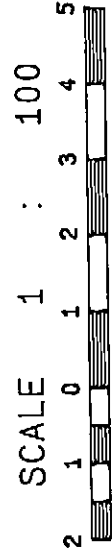

BUILDING 4

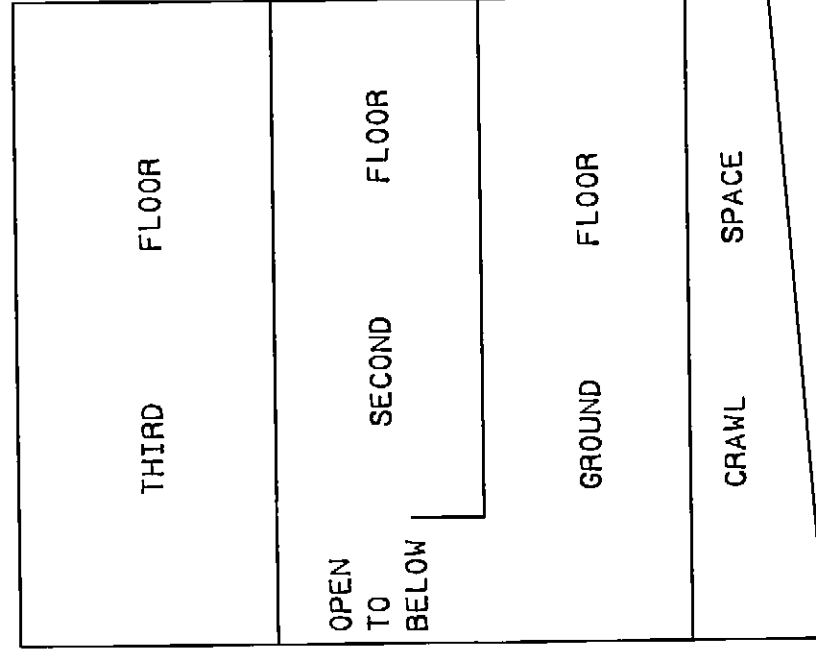

S.L. 7

CROSS-SECTION 'H-H'

NOTE:
 S.L. DENOTES STRATA LOT
 C.P. DENOTES COMMON PROPERTY
 L.C.P. DENOTES LIMITED COMMON PROPERTY
 C.F. DENOTES COMMON FACILITY
 PT. DENOTES PART
 B. DENOTES BALCONY
 BALCONIES ARE COMMON PROPERTY AND ARE NOT INCLUDED IN SQUARE METRE (M²) AREAS
 ALL DISTANCES ARE IN METRES.

BP
 _____ B.C.L.S.
December 6 1988

J88092

SP88324B

SHEET 40 OF 48 SHEETS

CROSS - SECTIONS

STRATA PLAN VR 2325

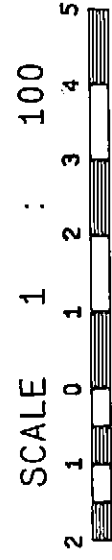

BUILDING 5

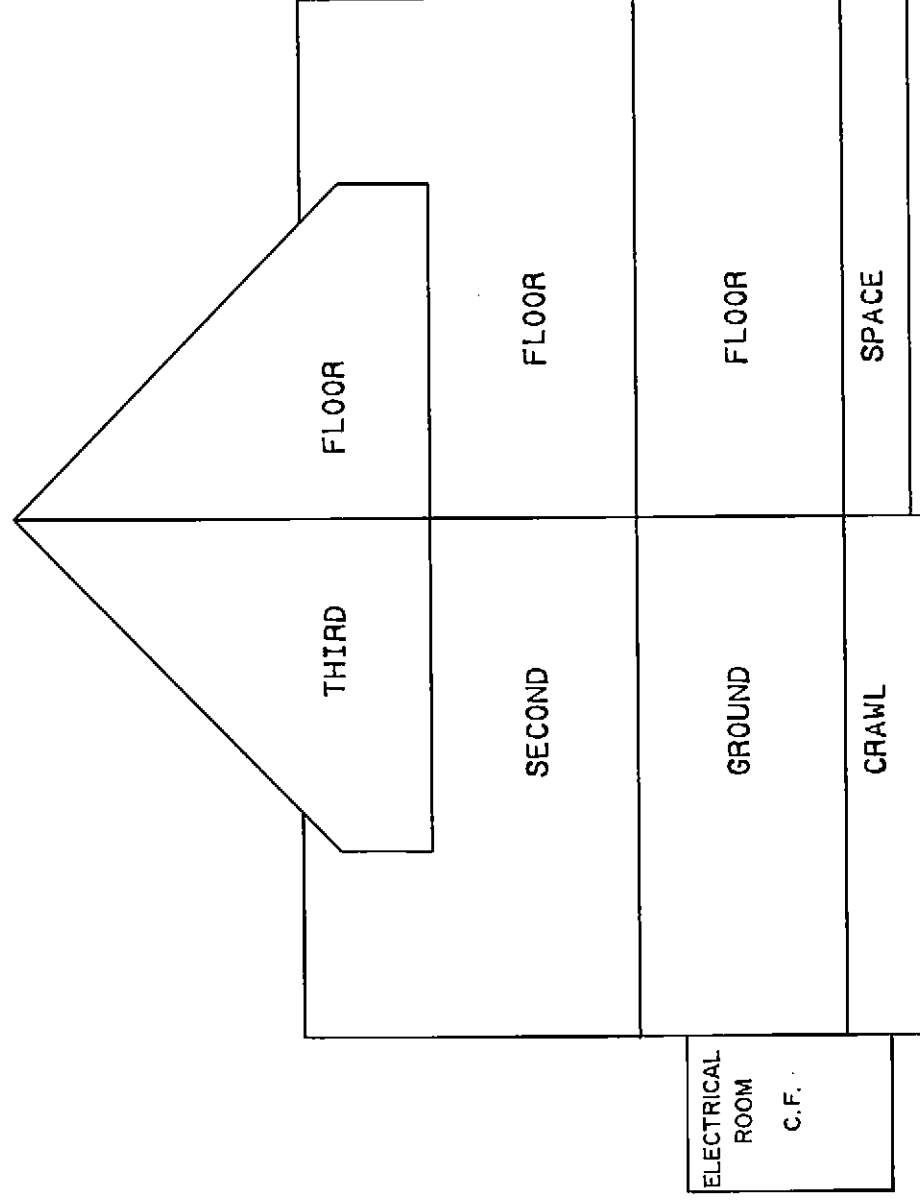

S.L. 9

S.L. 10

CROSS-SECTION 'I-I'

NOTE:
 S.L. DENOTES STRATA LOT
 C.P. DENOTES COMMON PROPERTY
 L.C.P. DENOTES LIMITED COMMON PROPERTY
 C.F. DENOTES COMMON FACILITY
 PT. DENOTES PART
 B. DENOTES BALCONY
 BALCONIES ARE COMMON PROPERTY AND ARE NOT INCLUDED IN SQUARE METRE (M²) AREAS
 ALL DISTANCES ARE IN METRES.

RB
 B.C.L.S.
 December 6 1988

J88092

SP88324B

SHEET 41 OF 48 SHEETS

CROSS - SECTIONS



STRATA PLAN VR 2325

BUILDING 5

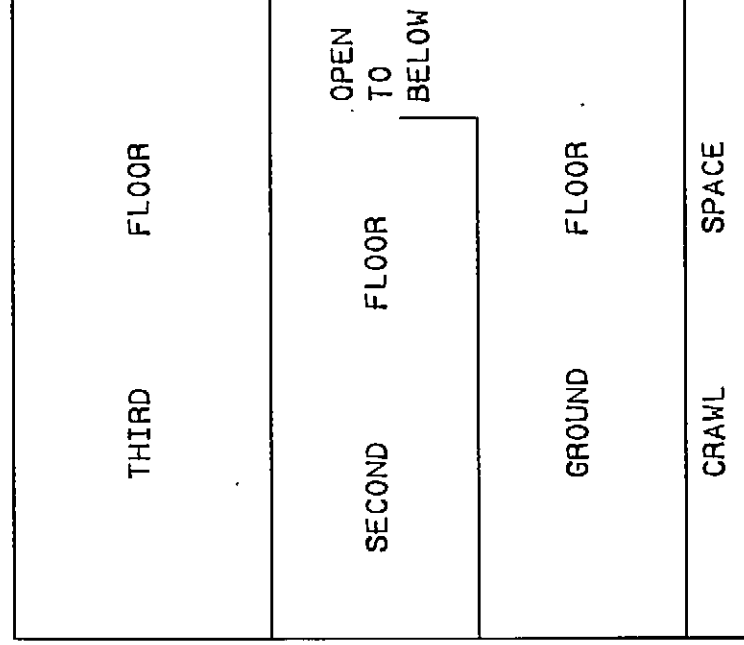

S.L. 9

CROSS-SECTION 'J-J'

NOTE:
 S.L. DENOTES STRATA LOT
 C.P. DENOTES COMMON PROPERTY
 L.C.P. DENOTES LIMITED COMMON PROPERTY
 C.F. DENOTES COMMON FACILITY
 PT. DENOTES PART
 B. DENOTES BALCONY
 BALCONIES ARE COMMON PROPERTY AND ARE NOT INCLUDED IN SQUARE METRE (M²) AREAS
 ALL DISTANCES ARE IN METRES.

BB
 _____ B.C.L.S.
December 6 1988

J88092

SP88324B

SHEET 42 OF 48 SHEETS

CROSS - SECTIONS

STRATA PLAN VR 2325



BUILDING 6

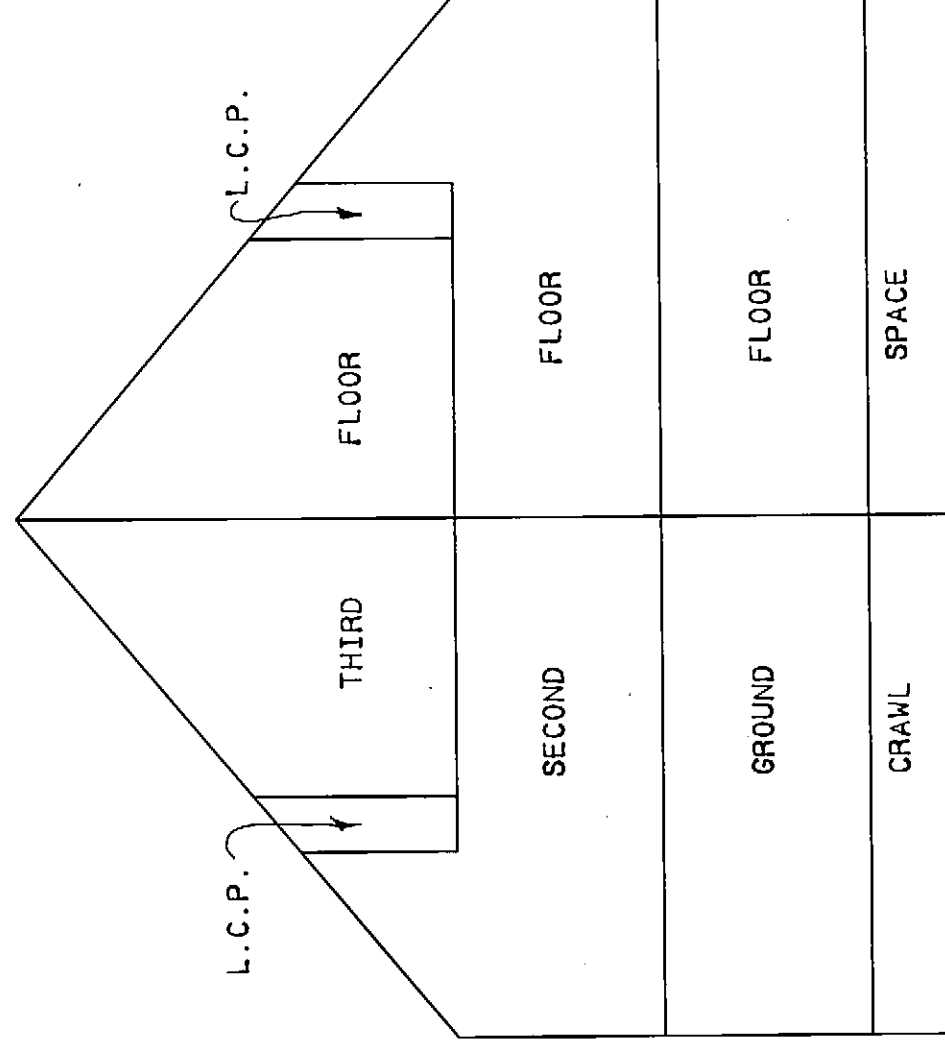

S.L. 11

S.L. 12

CROSS-SECTION 'K-K'

NOTE:
 S.L. DENOTES STRATA LOT
 C.P. DENOTES COMMON PROPERTY
 L.C.P. DENOTES LIMITED COMMON PROPERTY
 C.F. DENOTES COMMON FACILITY
 PT. DENOTES PART
 B. DENOTES BALCONY
 BALCONIES ARE COMMON PROPERTY AND ARE NOT INCLUDED IN SQUARE METRE (M²) AREAS
 ALL DISTANCES ARE IN METRES.

BB
 ----- B.C.L.S.
December 6 1988

J88092

SP88324B

SHEET 43 OF 48 SHEETS

CROSS - SECTIONS

STRATA PLAN VR 2325

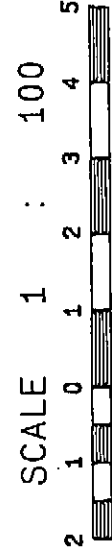

BUILDING 6

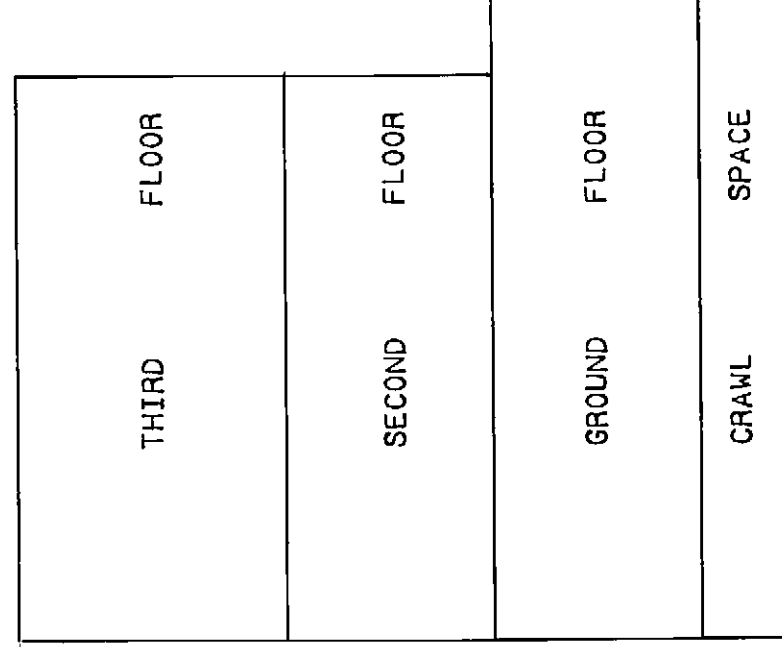

S.L. 12

CROSS-SECTION 'L-L'

NOTE:
 S.L. DENOTES STRATA LOT
 C.P. DENOTES COMMON PROPERTY
 L.C.P. DENOTES LIMITED COMMON PROPERTY
 C.F. DENOTES COMMON FACILITY
 PT. DENOTES PART
 B. DENOTES BALCONY
 BALCONIES ARE COMMON PROPERTY AND ARE NOT INCLUDED IN SQUARE METRE (M²) AREAS
 ALL DISTANCES ARE IN METRES.

RB
 _____ B.C.L.S.
 December 6 1988

J88092

SP88324B

CROSS - SECTIONS

SHEET 44 OF 48 SHEETS

STRATA PLAN VR 2025

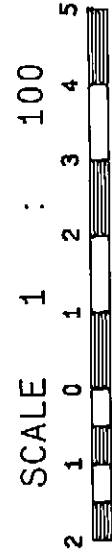

BUILDING 7

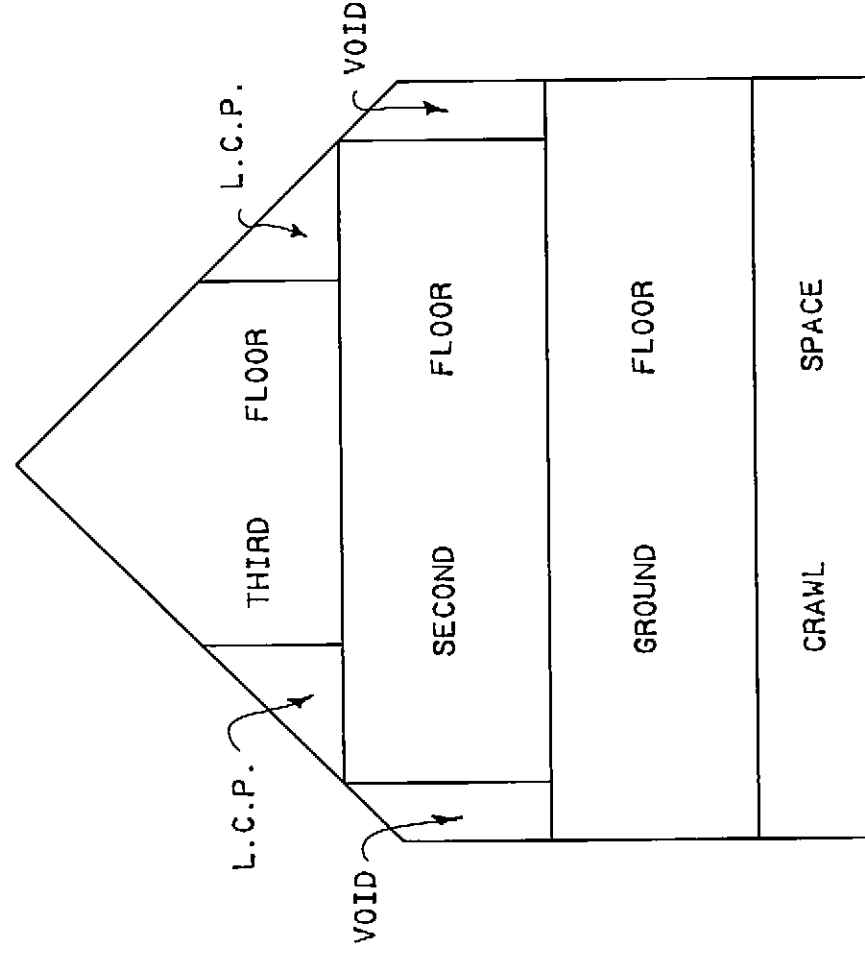

S.L. 13

CROSS-SECTION 'M-M'

NOTE:
 S.L. DENOTES STRATA LOT
 C.P. DENOTES COMMON PROPERTY
 L.C.P. DENOTES LIMITED COMMON PROPERTY
 C.F. DENOTES COMMON FACILITY
 PT. DENOTES PART
 B. DENOTES BALCONY
 BALCONIES ARE COMMON PROPERTY AND ARE NOT INCLUDED IN SQUARE METRE (M²) AREAS
 ALL DISTANCES ARE IN METRES.

BB

 December 6 1988
 B.C.L.S.

J88092

SP88324B

CROSS - SECTIONS

SHEET 45 OF 48 SHEETS

STRATA PLAN VR 2325

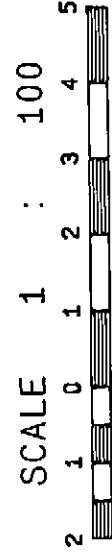

BUILDING 7

	L.C.P. FLOOR
THIRD	
SECOND	FLOOR
GROUND	FLOOR
CRAWL	SPACE

S.L. 13

CROSS-SECTION 'N-N'

NOTE:
 S.L. DENOTES STRATA LOT
 C.P. DENOTES COMMON PROPERTY
 L.C.P. DENOTES LIMITED COMMON PROPERTY
 C.F. DENOTES COMMON FACILITY
 PT. DENOTES PART
 B. DENOTES BALCONY
 BALCONIES ARE COMMON PROPERTY AND ARE NOT INCLUDED IN SQUARE METRE (M²) AREAS
 ALL DISTANCES ARE IN METRES.

BB
 _____ B.C.L.S.
December 6 1988

J88092

SP88324B

SHEET 46 OF 48 SHEETS

PLAN OF L.C.P. FOR STRATA LOTS 1-13

STRATA PLAN VR 2325

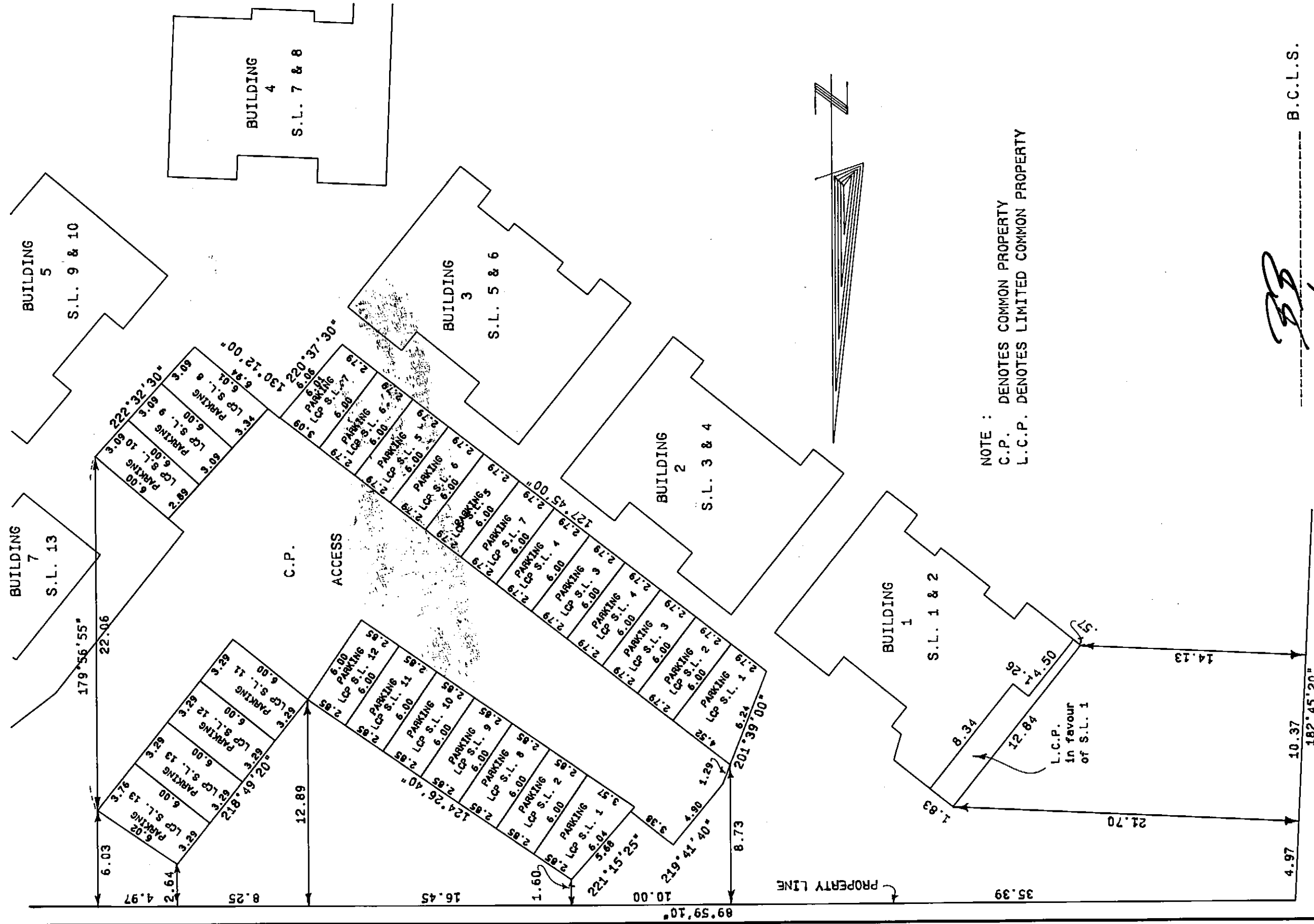
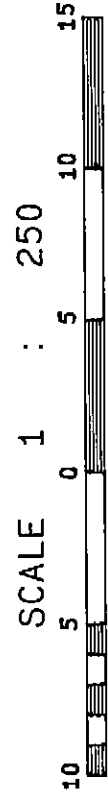

NOTE :
 C.P. DENOTES COMMON PROPERTY
 L.C.P. DENOTES LIMITED COMMON PROPERTY

BB
 December 6 1988
 B.C.L.S.

J88092

SP88324B

SHEET 48 OF 48 SHEETS

STRATA PLAN VR 2325

Common Property Sheet Closed 21/10/95

Search ALTOS2 or BC OnLine for Current Information. BC Reg. 76/95

Woh

Vancouver/New Westminster
 DENVAL J. DINIUS, Registrar
 Title District

AFFECTING THE COMMON PROPERTY

FILING		DOCUMENT	
NUMBER	DATE	DATE	NATURE AND PARTICULARS
SUBJECT TO PROVISO, SEE DISTRICT LOT 4979			CROWN GRANT L31152; PART DERIVED FROM
SUBJECT TO PROVISO, SEE FORMER BLOCKS O AND T			CROWN GRANT L 31154; PART DERIVED FROM DISTRICT LOT 7179 PLAN 19693
SUBJECT TO PROVISOS, SEE L 31172	30/3/83		CROWN GRANT R 96399
			UNDERSURFACE RIGHTS & OTHER EXCEPTIONS & RESERVATIONS; SECTION 47
			LAND ACT, SEE CROWN GRANT L 31154
			PART DERIVED FROM FORMER BLOCKS O AND T DISTRICT LOT 7179 PLAN 19693; INTER ALIA
L 31153	30/3/83		UNDERSURFACE RIGHTS & OTHER EXCEPTIONS & RESERVATIONS; SECTION 47
			LAND ACT, SEE CROWN GRANT L 31152
			PART DERIVED FROM DISTRICT LOT 4979 INTER ALIA
P 12312	6/8/86		COVENANT IN FAVOUR OF RESORT MUNICIPALITY OF WHISTLER; S. 215 L.T.A. MODIFIED BY R124664, 1/12/87
			INTER ALIA

BB
 B.C.L.S.
 December 6 1988

SHEET 48A OF 48 SHEETS

STRATA PLAN VR 2325

DECLARATIONS AFFECTING THE COMMON PROPERTY

Common Property Sheet Closed 27/10/95
 Search ALTOS2 or BC OnLine for
 Current Information. BC Reg. 76/95
 LINDA J. O'SHEA, Registrar
 Vancouver/New Westminster
 LINDA J. O'SHEA, Registrar
 Vancouver/New Westminster

Wain

FILING		DOCUMENT
NUMBER	DATE	NATURE AND PARTICULARS
R 108118	22/10/87	UNDER-SURFACE RIGHTS & OTHER EXCEPTIONS & RESERVATIONS; SECTION 47 LAND ACT, SEE CROWN GRANT R96399; INTER ALIA
R 124664	1/12/87	COVENANT; MODIFICATION OF COVENANT P12312; INTER ALIA

BB
 B.C.L.S. _____
 December 6 1988