

SECOND SHEET, SHEET 4 OF 23 SHEETS

STRATA PLAN LMS 1816

CONDOMINIUM ACT

Table with 5 columns: LOT NUMBER, SHEET NUMBER, FORM 1 (SCHEDULE OF UNIT ENTITLEMENT), FORM 2 (SCHEDULE OF INTEREST UPON DESTRUCTION), FORM 3 (SCHEDULE OF VOTING RIGHTS). Rows 1-50.

DRAWING # 30084-2 FILE # 3084-FSS.DWG

DATE: DEC. 21, 1994

M.E.S.

SECOND SHEET, SHEET 5 OF 23 SHEETS

STRATA PLAN LMS 1816

CONDOMINIUM ACT

Table with 5 columns: LOT NUMBER, SHEET NUMBER, FORM 1 (SCHEDULE OF UNIT ENTITLEMENT), FORM 2 (SCHEDULE OF INTEREST UPON DESTRUCTION), FORM 3 (SCHEDULE OF VOTING RIGHTS). Rows 51-82 and AGGREGATE.

ACCEPTED AS TO FORMS 1, 2 AND 3 THIS 12 DAY OF January, 1995

for: [Signature] SUPERINTENDENT OF REAL ESTATE

DRAWING # 30084-2 FILE # 3084-FSS.DWG

DATE: DEC. 21, 1994

M.E.S.

SECOND SHEET, SHEET 6 OF 23 SHEETS

STRATA PLAN LMS 1816

STATUTORY DECLARATION

I, THE UNDERSIGNED DO SOLEMNLY DECLARE THAT: 1) I, THE UNDERSIGNED AM THE ONLY AUTHORIZED AGENT OF THE OWNER / DEVELOPER. 2) THE STRATA PLAN IS FOR RESIDENTIAL USE ONLY. I MAKE THIS SOLEMN DECLARATION CONSCIOUSLY BELIEVING IT TO BE TRUE AND KNOWING IT IS OF THE SAME FORCE AND EFFECT AS IF MADE UNDER OATH.

DECLARED BEFORE ME AT VANCOUVER IN THE PROVINCE OF BRITISH COLUMBIA THIS 9th DAY OF JANUARY, 1994.

[Signature] COMMISSIONER FOR TAKING AFFIDAVITS WITHIN THE PROVINCE OF BRITISH COLUMBIA RUSSELL [Signature]

I, MIKE E. SHAW, BRITISH COLUMBIA LAND SURVEYOR, HEREBY CERTIFY THAT THE BUILDING SHOWN IN THIS STRATA PLAN HAS NOT, AS AT THE 21st DAY OF DECEMBER, 1994, BEEN PREVIOUSLY OCCUPIED.

DATED AT SURREY, B.C. THIS 21st DAY OF DECEMBER, 1994.

[Signature] B.C.L.S.

OWNERS:

NORTH FRASER LANDING LTD. (INCORPORATION NO. 304161) 37116 ACTHURST ST. SCAMATOVA

[Signatures] GUY YOUNG, JIM MENDELSON, RUSSELL [Signature]

WITNESS: JIM MENDELSON, 1500-777 DUNSMUIR ST. VANCOUVER, B.C. V7L 1L8 ADDRESS OF WITNESS: 643-7100

MORTGAGEE:

BRANDLEY DEVELOPMENTS LIMITED (REG. NO. A38877) 84116 ACTHURST ST. SCAMATOVA

[Signatures] JIM MENDELSON, Guy Young

WITNESS: CORA P. YEE, MGR. INFORMATION SERVICES, 2061 E. 41st Ave., Vancouver, B.C.

MORTGAGEE: HONOLULU BANK OF CANADA 57116 ACTHURST ST. VANCOUVER

[Signatures] WYNNE BORG, Z.S. MORRIS

WITNESS: BRANKER, 885 W. GEORGIA ST. VANCOUVER, B.C.

MORTGAGEE: INTERMARK CORPORATION (INC. NO. 200488) 8710'S RICHMOND ST. VANCOUVER

[Signatures] JOE HOUTSIAN, DAN JARVIS

WITNESS: CLAUDETTE COLBY, ADMIN. ASSISTANT, 800-800 BLUARDI

ADDRESS OF WITNESS

MORTGAGEE: REBEL COOKE GROUP LIMITED (INC. NO. 278738) 8710'S RICHMOND ST. VANCOUVER

[Signatures] GEORGE REBEL, RANDY COOKE

WITNESS: MARGARET JARVIS, NANCY FOREST

WITNESS: JIM MENDELSON, 1500-777 DUNSMUIR ST. VANCOUVER, B.C.

DRAWING # 30084-2 FILE # 3084-FSS.DWG

DATE: DEC. 21, 1994

M.E.S.

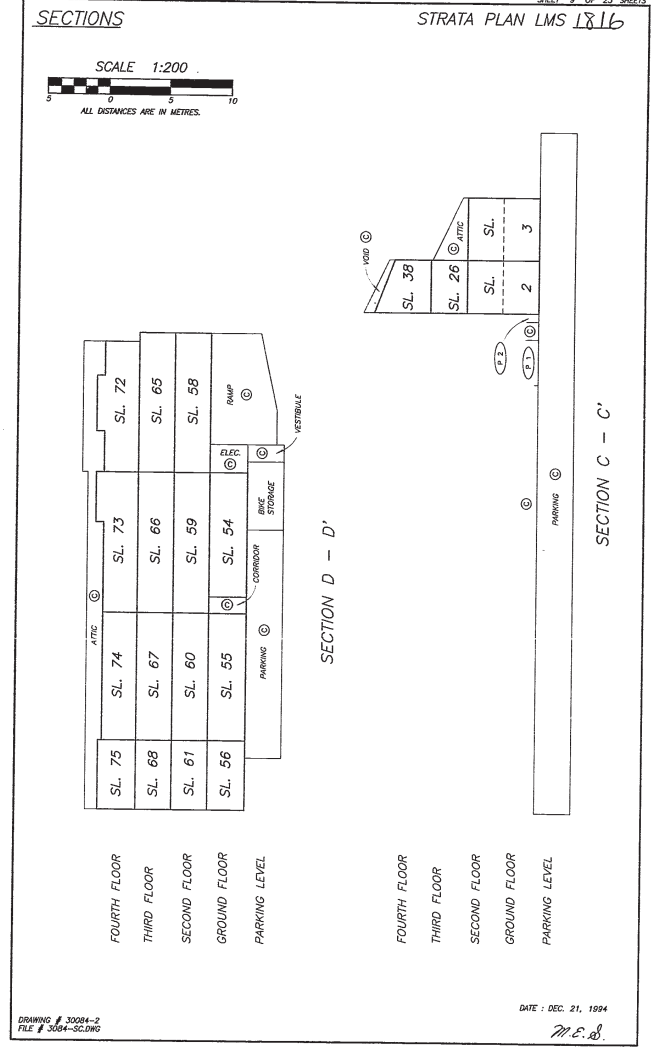
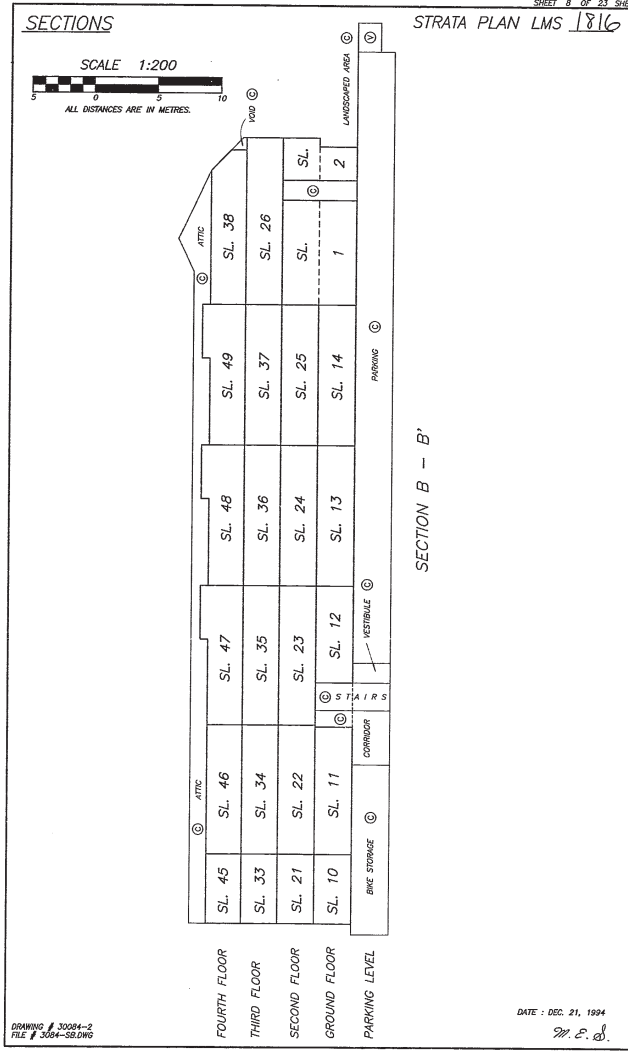
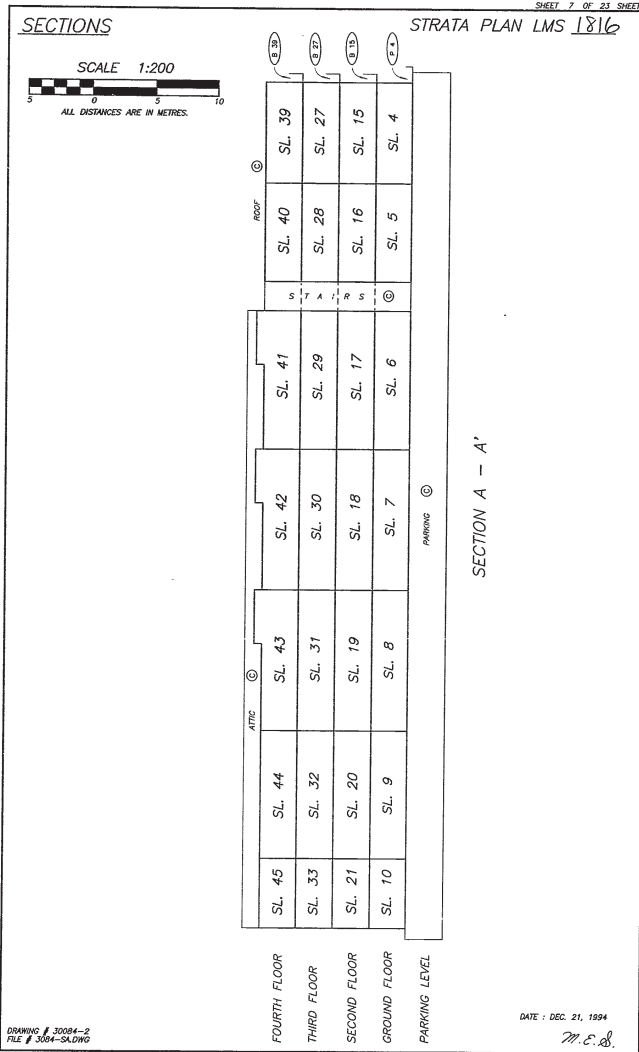

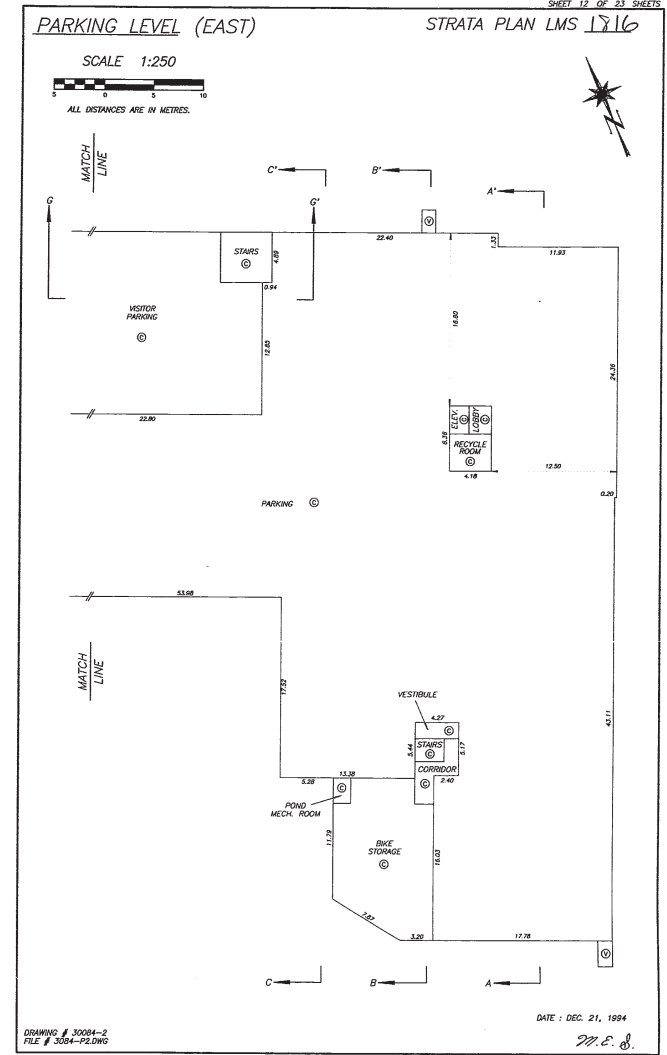
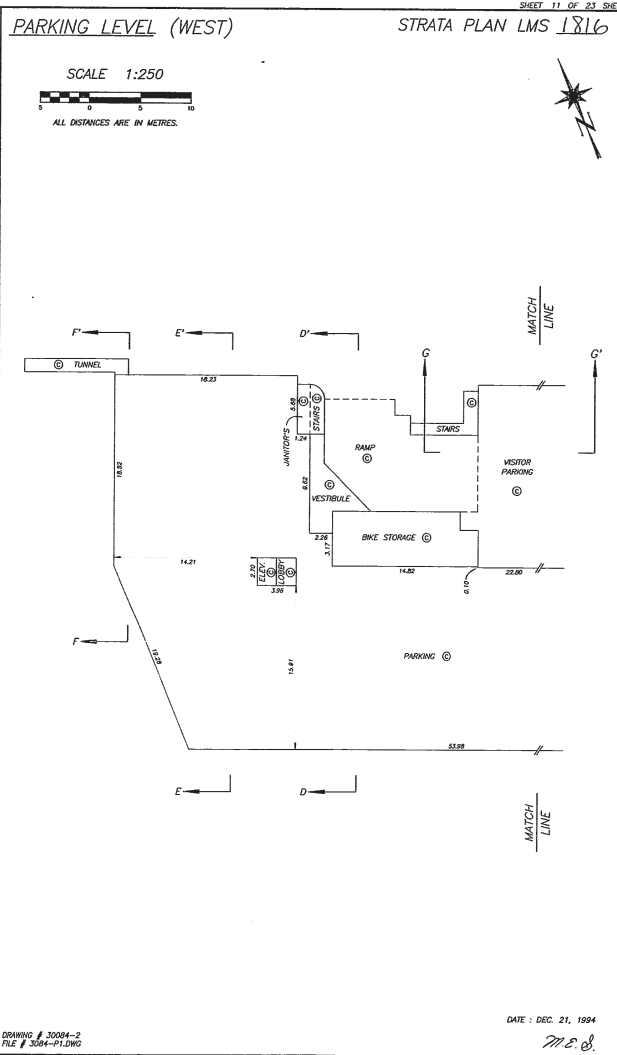
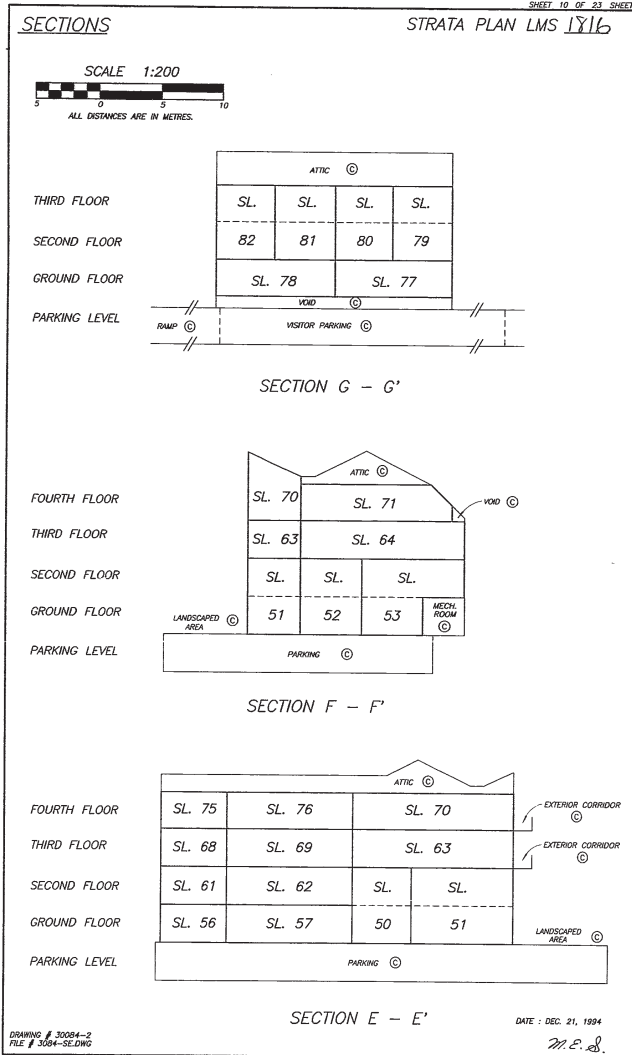

SHEET 13 OF 23 SHEETS

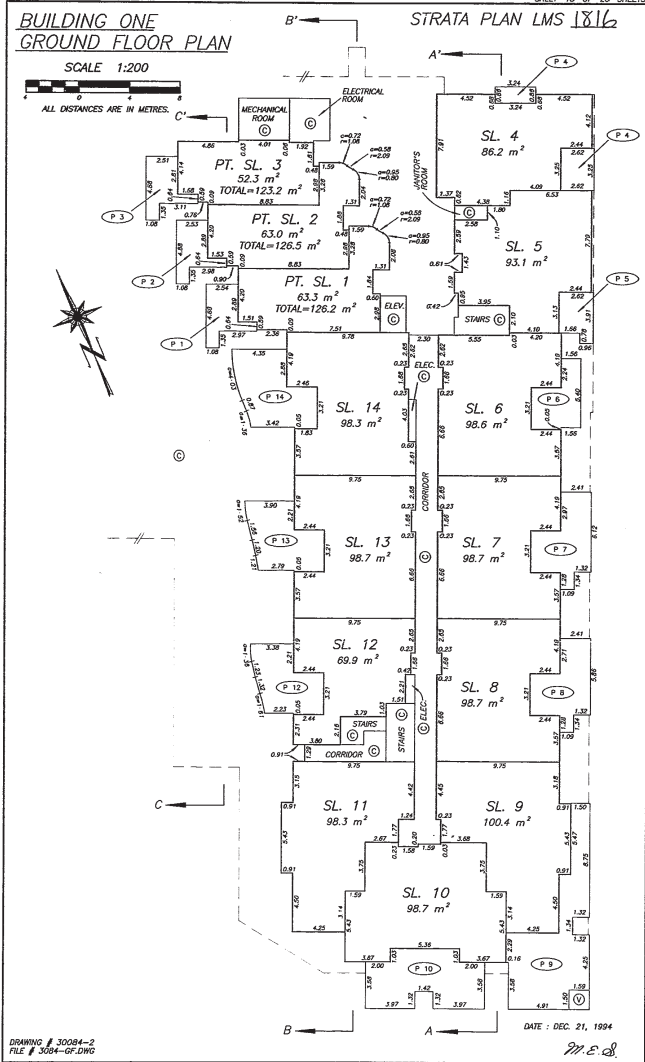

SHEET 14 OF 23 SHEETS

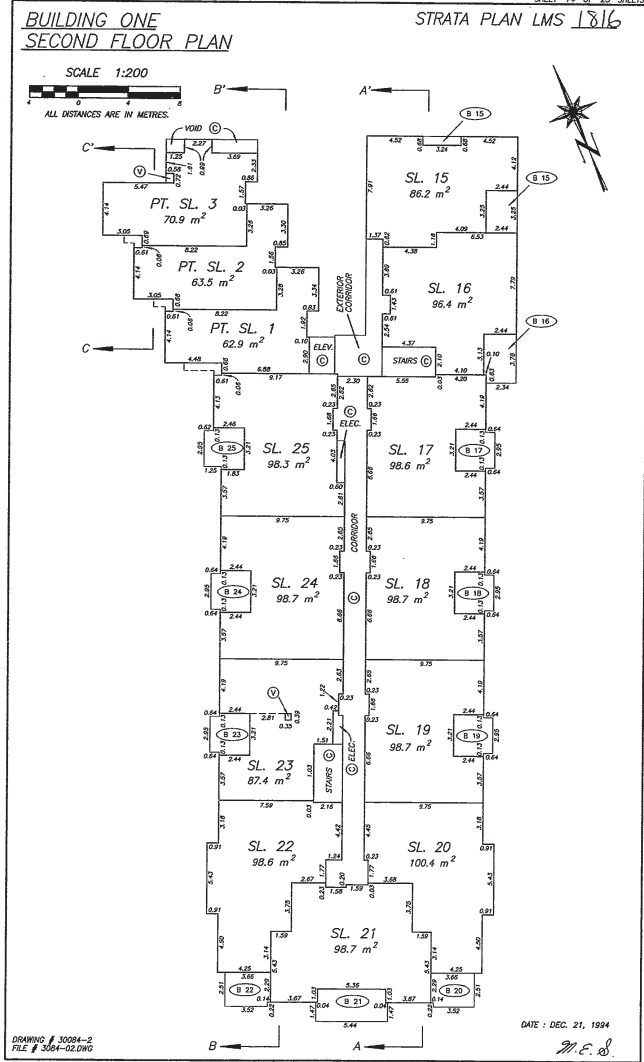

SHEET 15 OF 23 SHEETS

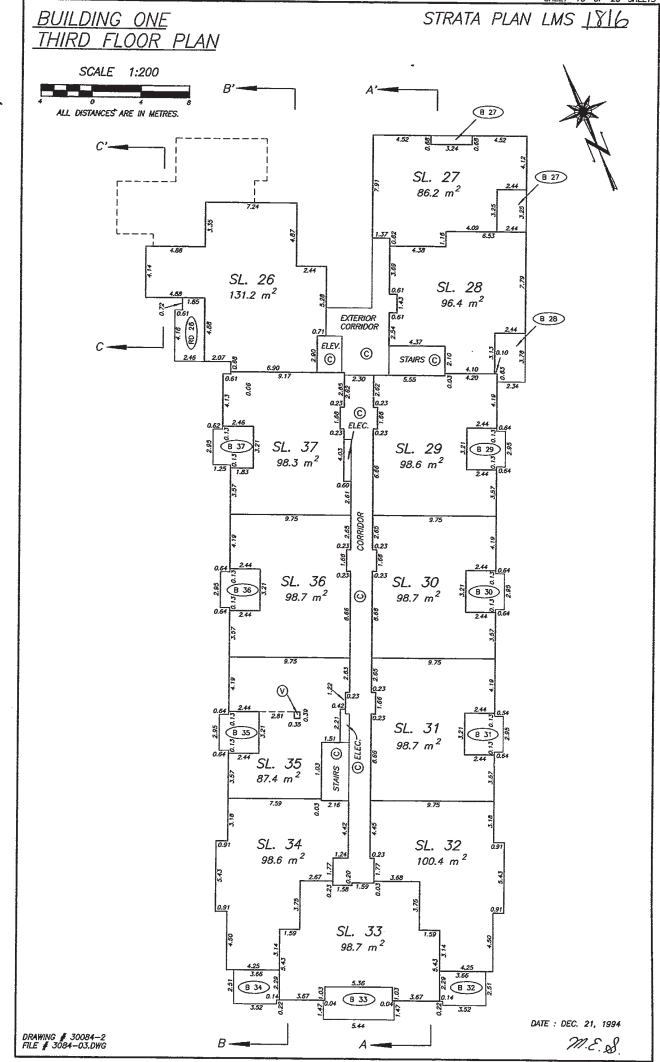

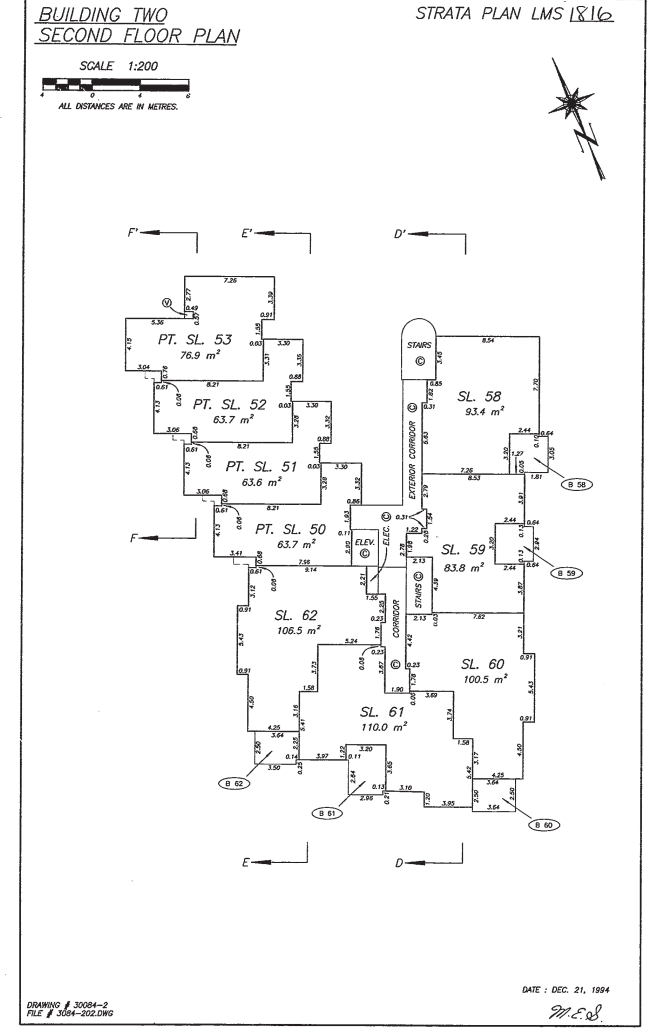
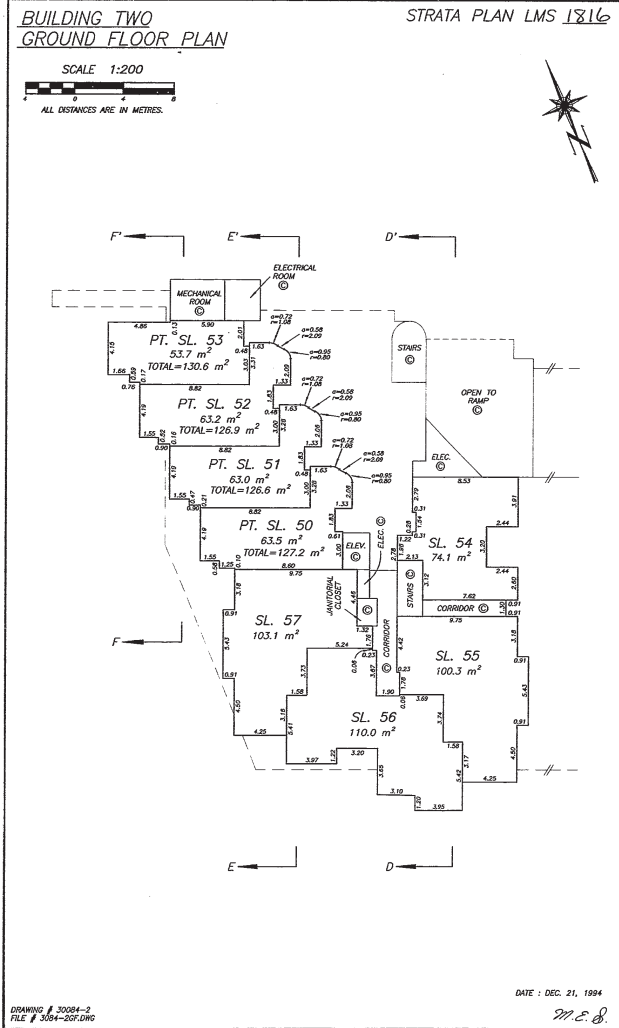
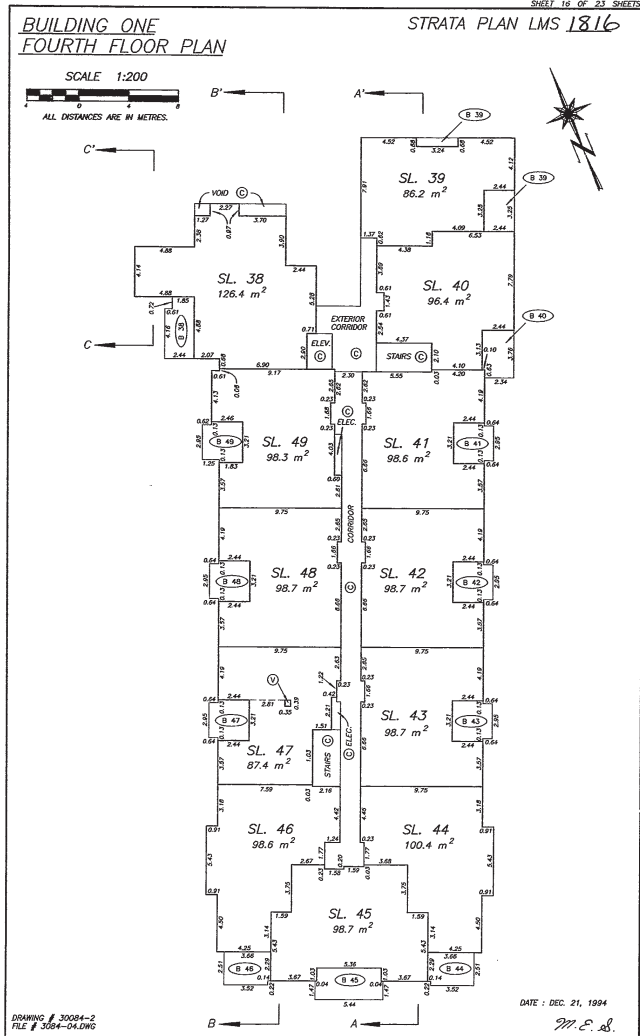

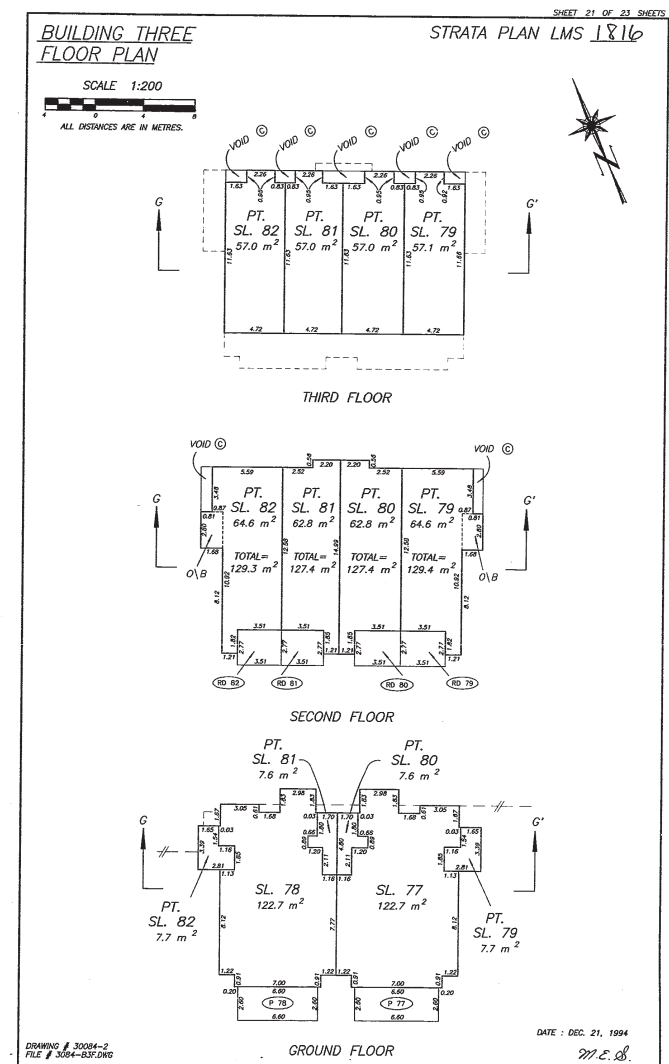
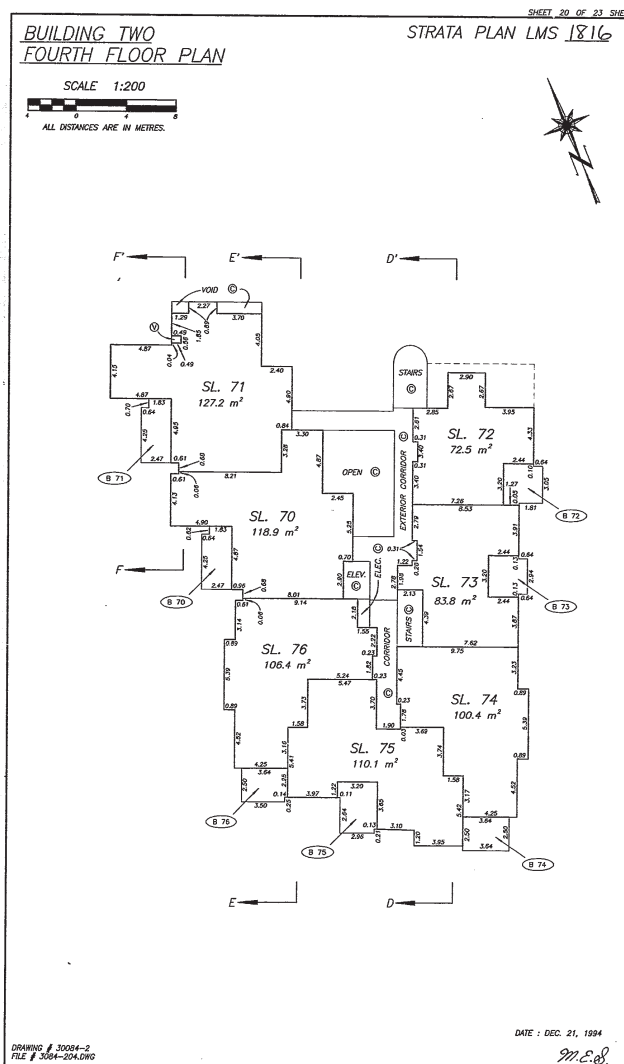
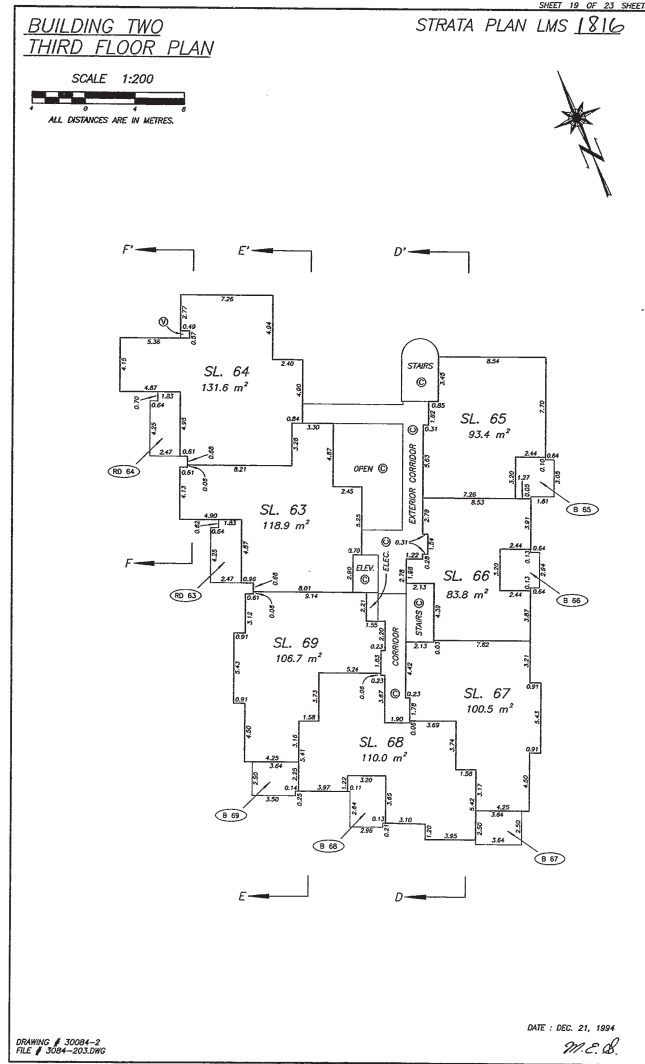

STRATA PLAN LMS 1816
RECORD OF BY-LAWS
AND ORDERS ETC.

STRATA PLAN LMS 1816
DEALINGS AFFECTING THE
COMMON PROPERTY

| FILING | | DOCUMENT | |
|---------|------------|----------|----------------------------------|
| NUMBER | DATE | DATE | NATURE AND PARTICULARS |
| BJ35401 | 03/02/1995 | | NOTIFICATION OF CHANGE OF BYLAWS |
| | | | |
| | | | |
| | | | |
| | | | |
| | | | |
| | | | |
| | | | |
| | | | |
| | | | |
| | | | |
| | | | |
| | | | |
| | | | |
| | | | |
| | | | |
| | | | |
| | | | |
| | | | |
| | | | |
| | | | |
| | | | |
| | | | |
| | | | |
| | | | |
| | | | |
| | | | |
| | | | |
| | | | |
| | | | |
| | | | |
| | | | |
| | | | |
| | | | |
| | | | |

| REGISTRATION | | DOCUMENT | |
|---|------------|----------|---|
| NUMBER | DATE | DATE | NATURE AND PARTICULARS |
| SUBJECT TO PROVISOS SEE CROWN GRANT BG354861 AS TO PART FORMERLY DISTRICT LOT 7825 | | | |
| HERETO IS ANNEXED EASEMENT BH45185 OVER THE COMMON PROPERTY OF STRATA PLAN LMS 1820 | | | |
| GD116528 | 02/11/1990 | | COVENANT; CITY OF VANCOUVER; SEC. 215 LAND TITLE ACT; INCLUDES INDEMNITY UNDER S.215(2)(A) L.T.A.; INTER ALIA AS TO ALL, EXCEPT PART FORMERLY DISTRICT LOT 7825 MODIFIED BY BH33449 |
| GD116530 | 02/11/1990 | | STATUTORY RIGHT OF WAY; CITY OF VANCOUVER; INTER ALIA; AS TO ALL, EXCEPT PART FORMERLY DISTRICT LOT 7825 |
| GD116533 | 02/11/1990 | | COVENANT; CITY OF VANCOUVER; SECTION 215 LAND TITLE ACT; INTER ALIA, AS TO ALL, EXCEPT PART FORMERLY DISTRICT LOT 7825 MODIFIED BY BH33459 |
| GD116534 | 02/11/1990 | | COVENANT; CITY OF VANCOUVER; SECTION 215 LAND TITLE ACT; INCLUDES INDEMNITY UNDER S.215(2)(A) L.T.A.; INTER ALIA; AS TO ALL, EXCEPT PART FORMERLY DISTRICT LOT 7825 |
| GD116556 | 02/11/1990 | | COVENANT; CITY OF VANCOUVER; SECTION 215, LAND TITLE ACT; INTER ALIA; AS TO ALL, EXCEPT PART FORMERLY DISTRICT LOT 7825; MODIFIED BY BH33449 |
| GD116588 | 02/11/1990 | | COVENANT; CITY OF VANCOUVER; SECTION 215, LAND TITLE ACT; INTER ALIA; AS TO ALL, EXCEPT PART FORMERLY DISTRICT LOT 7825 |
| | | | |
| | | | |
| | | | |
| | | | |
| | | | |
| | | | |
| | | | |
| | | | |
| | | | |
| | | | |
| | | | |
| | | | |
| | | | |
| | | | |
| | | | |
| | | | |
| | | | |
| | | | |
| | | | |
| | | | |
| | | | |
| | | | |

DATE: 24 OF 25 SHEETS
 PLAN LMS 1816

| DOCUMENT | NATURE AND PARTICULARS |
|----------------------|--|
| GD116599 02/11/1990 | COVENANT; CITY OF VANCOUVER; SECTION 215, LAND TITLE ACT, INCLUDES INDEMNITY UNDER S. 215(2)(A) L.T.A.; INTER ALIA AS TO ALL, EXCEPT PART FORMERLY DISTRICT LOT 7825 |
| GD116600 02/11/1990 | STATUTORY RIGHT OF WAY; CITY OF VANCOUVER; INTER ALIA; AS TO ALL, EXCEPT PART FORMERLY DISTRICT LOT 7825 |
| BH 33374 31/01/1994 | COVENANT, CITY OF VANCOUVER AND HER MAJESTY THE QUEEN IN THE RIGHT OF THE PROVINCE OF BRITISH COLUMBIA; SECTION 215 L.T.A.; INTER ALIA |
| BG 354865 30/09/1993 | UNDER-SURFACE RIGHTS; EXCEPTIONS AND RESERVATIONS LAND ACT SECTION 47 SEE BG 354861; INTER ALIA; AS TO PART FORMERLY DISTRICT LOT 7825 |
| BG 354866 30/09/1993 | STATUTORY RIGHT OF WAY; HER MAJESTY THE QUEEN IN RIGHT OF THE PROVINCE OF BRITISH COLUMBIA; INTER ALIA; AS TO PART FORMERLY DISTRICT LOT 7825 |
| BH 33416 31/01/1994 | STATUTORY RIGHT OF WAY; CITY OF VANCOUVER; INTER ALIA. |
| BH 33417 31/01/1994 | COVENANT; CITY OF VANCOUVER; SECTION 215 L.T.A.; INTER ALIA. |
| BH 33418 31/01/1994 | STATUTORY RIGHT OF WAY; CITY OF VANCOUVER; INTER ALIA. |
| BH 33419 31/01/1994 | EQUITABLE CHARGE; CITY OF VANCOUVER; INTER ALIA. |

DATE: DEC 21, 1994
 M.C.B.

| | |
|---------------------|---|
| BH33420 31/01/1994 | COVENANT; CITY OF VANCOUVER; SECTION 215 L.T.A.; INTER ALIA. |
| BH33430 31/01/1994 | STATUTORY RIGHT OF WAY; BRITISH COLUMBIA HYDRO AND POWER AUTHORITY; PLAN LMP 14788; INTER ALIA. |
| BH 33436 31/01/1994 | STATUTORY RIGHT OF WAY; CITY OF VANCOUVER; INTER ALIA. |
| BH 33437 31/01/1994 | COVENANT; CITY OF VANCOUVER; SECTION 215 L.T.A.; INTER ALIA. |
| BH 33438 31/01/1994 | COVENANT, CITY OF VANCOUVER; SECTION 215 L.T.A.; INTER ALIA. |
| BH 33444 31/01/1994 | EASEMENT AND INDEMNITY AGREEMENT; CITY OF VANCOUVER; INTER ALIA. |
| BH 33445 31/01/1994 | EQUITABLE CHARGE; CITY OF VANCOUVER; INTER ALIA. |
| BH33448 31/01/1994 | COVENANT; MODIFICATION OF GD116528; INTER ALIA. |
| BH 33449 31/01/1994 | COVENANT; MODIFICATION OF GD116556; INTER ALIA. |
| BH 33455 31/01/1994 | EASEMENT AND INDEMNITY AGREEMENT; CITY OF VANCOUVER; INTER ALIA. |
| BH33456 31/01/1994 | EQUITABLE CHARGE; CITY OF VANCOUVER; INTER ALIA. |
| BH33459 31/01/1994 | COVENANT; MODIFICATION OF GD116533; INTER ALIA. |

| | |
|--------------------|--|
| BH33475 31/01/1994 | EASEMENT AND INDEMNITY AGREEMENT; CITY OF VANCOUVER; INTER ALIA. |
| BH33476 31/01/1994 | EQUITABLE CHARGE; CITY OF VANCOUVER; INTER ALIA. |
| BH33477 31/01/1994 | COVENANT; CITY OF VANCOUVER; SECTION 215 L.T.A.; INTER ALIA. |